



Developing profitable customers



MC850^{flex} COMPACTOR

PARTS LIST



This parts list

Version: MC850flex.PL.1B
From chassis number: 21229000

Instructions for ordering spare parts

Illustrated parts are marked with part numbers.

To avoid errors, each part order must include the following information:

- Part number and description of part
- Quantity of parts required
- Chassis number

The chassis number is stamped into the model identification plate on the machine. It is essential to quote this chassis number in full in all enquiries and spare part orders.

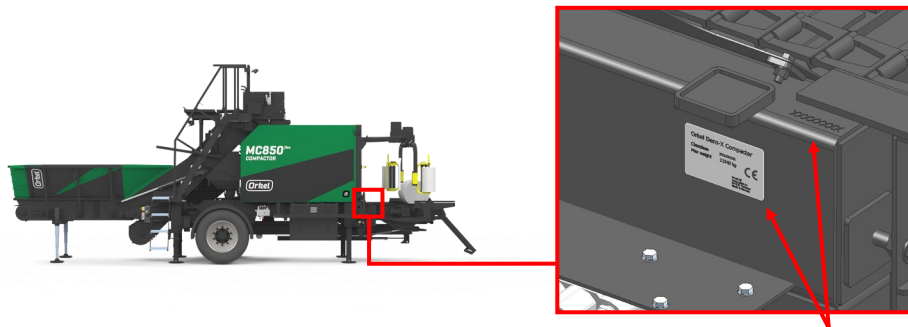

Chassis no.

Disclaimer

The original parts used on an Orkel® machine are designed and built to provide optimum fit, function, safety, and structural integrity. For this reason, Orkel® DOES NOT in any circumstance approve of the use of aftermarket, gray market, or imitation parts.

The information provided by Orkel® hereunder is provided “as is, where is” and with all faults, and the entire risk associated with such information is entirely with the Buyer.

Orkel® does not grant, explicitly or implicitly, to any party any patent rights, licenses, or any other IP rights, whether with regard to such information itself or anything described by such information.

Information provided in this document is proprietary to Orkel®, and Orkel® reserves the right, at its sole discretion, to make any changes or modification to the information in this document or to any products and services at any time without notice.

Orkel® does not assume responsibility for any damages associated with a machine and/or part failure caused by the use of parts other than genuine Orkel® replacement parts, neither do we assume responsibility for any changes to the product made after initial delivery.



Johan Gjønnnes' veg 25
7320 Fannrem
Norway



Spare parts:

+47 913 23 511

Technical Support:

+47 918 43 553



parts@orkel.no



orkel.com



User resources
orkel.com/gr/flex

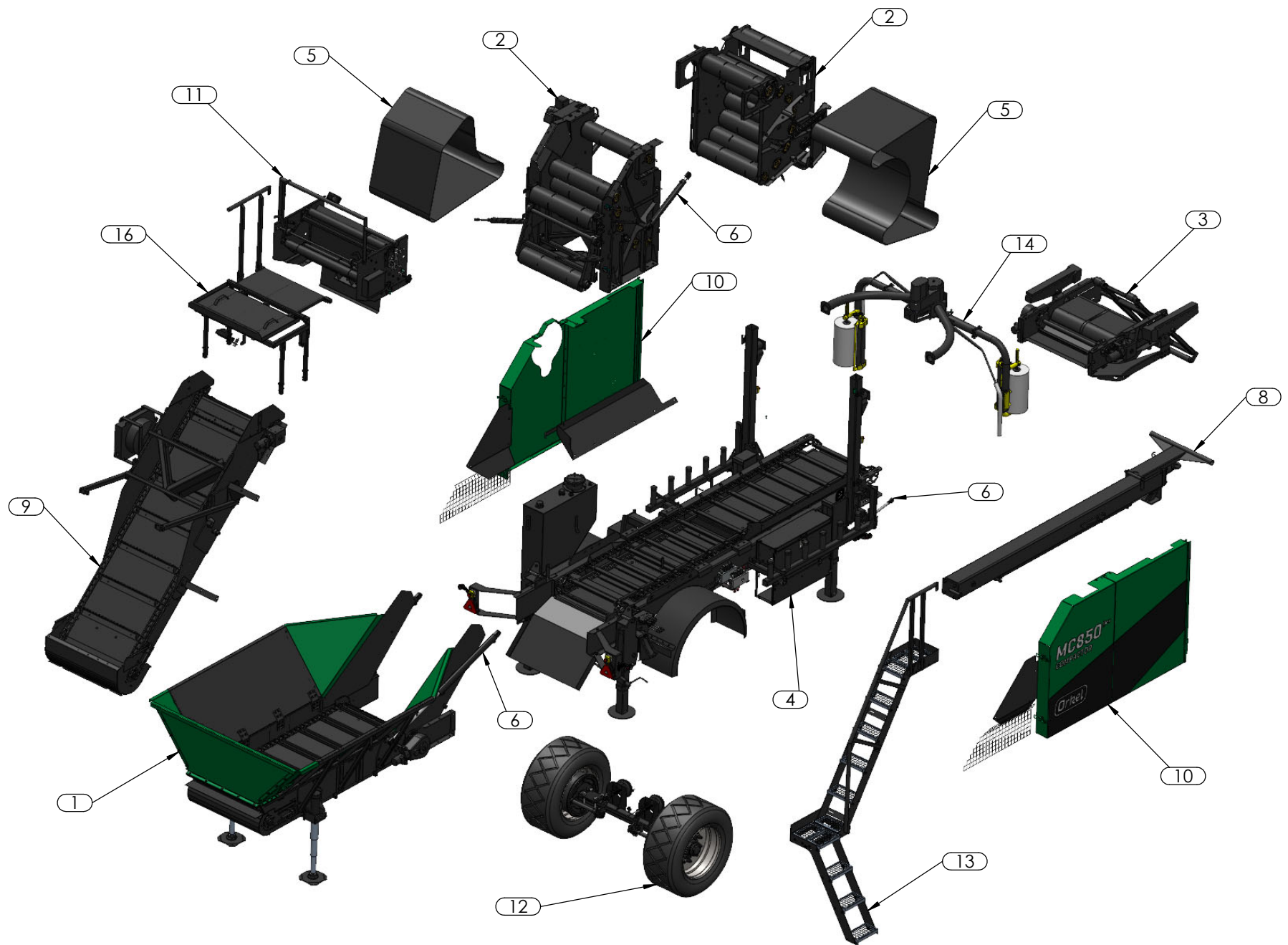

CONTENTS

- 1 Feed hopper F5
 - 2 (a) Front chamber
 - 3 Wrapping table
 - 4 Frame
 - 5 Belts
 - 6 Hydraulics
 - 7 Electric
 - 8 Drawbar & PTO shaft
 - 9 Elevator
 - 10 Covers
 - 11 Plastic tying unit
 - 12 Wheel suspension
 - 13 Stairs
 - 14 Wrapping arms
 - 15 Optional equipment
 - 16 Platform
 - 17 Central lubrication system
- (b) Rear chamber

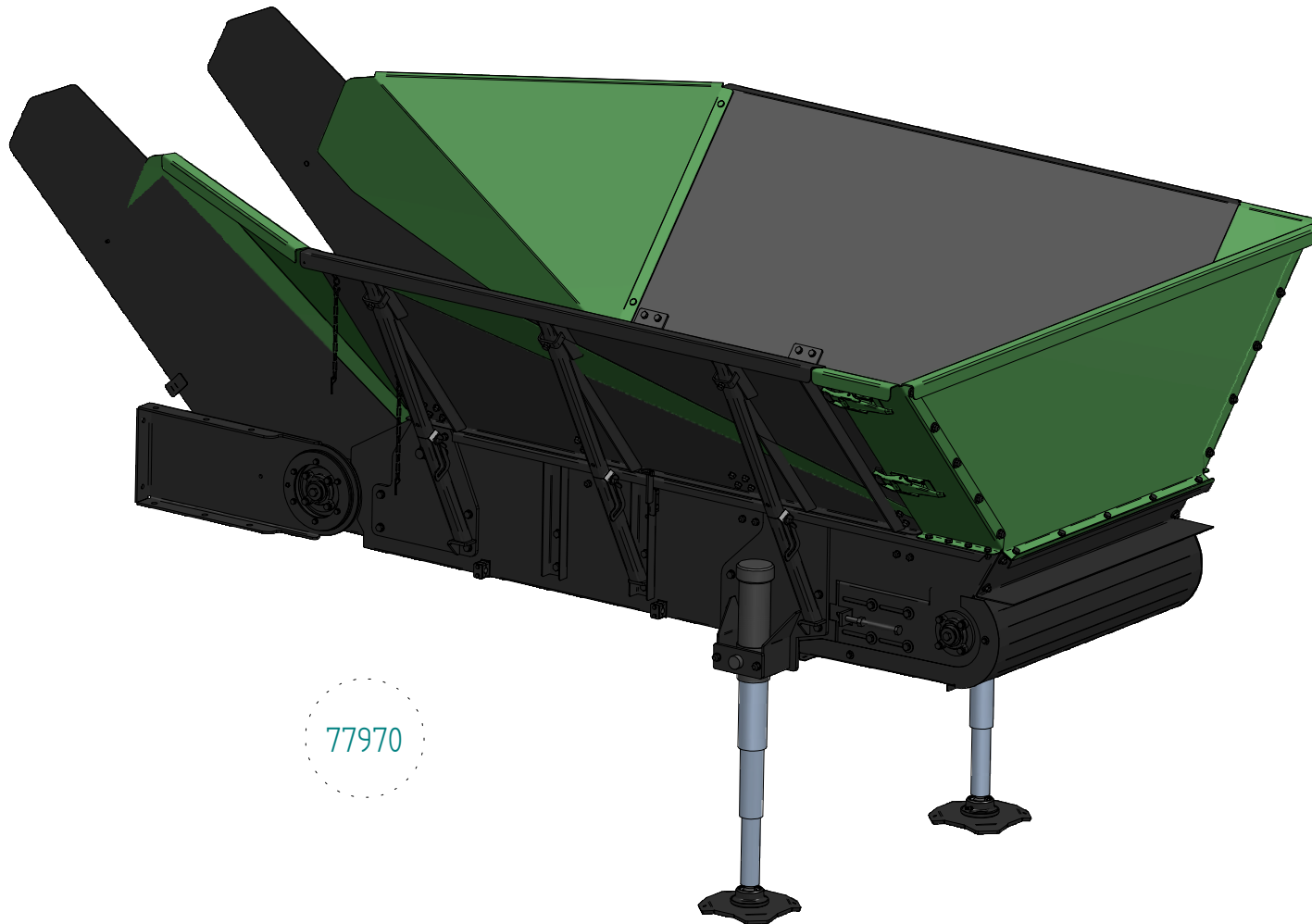

77970

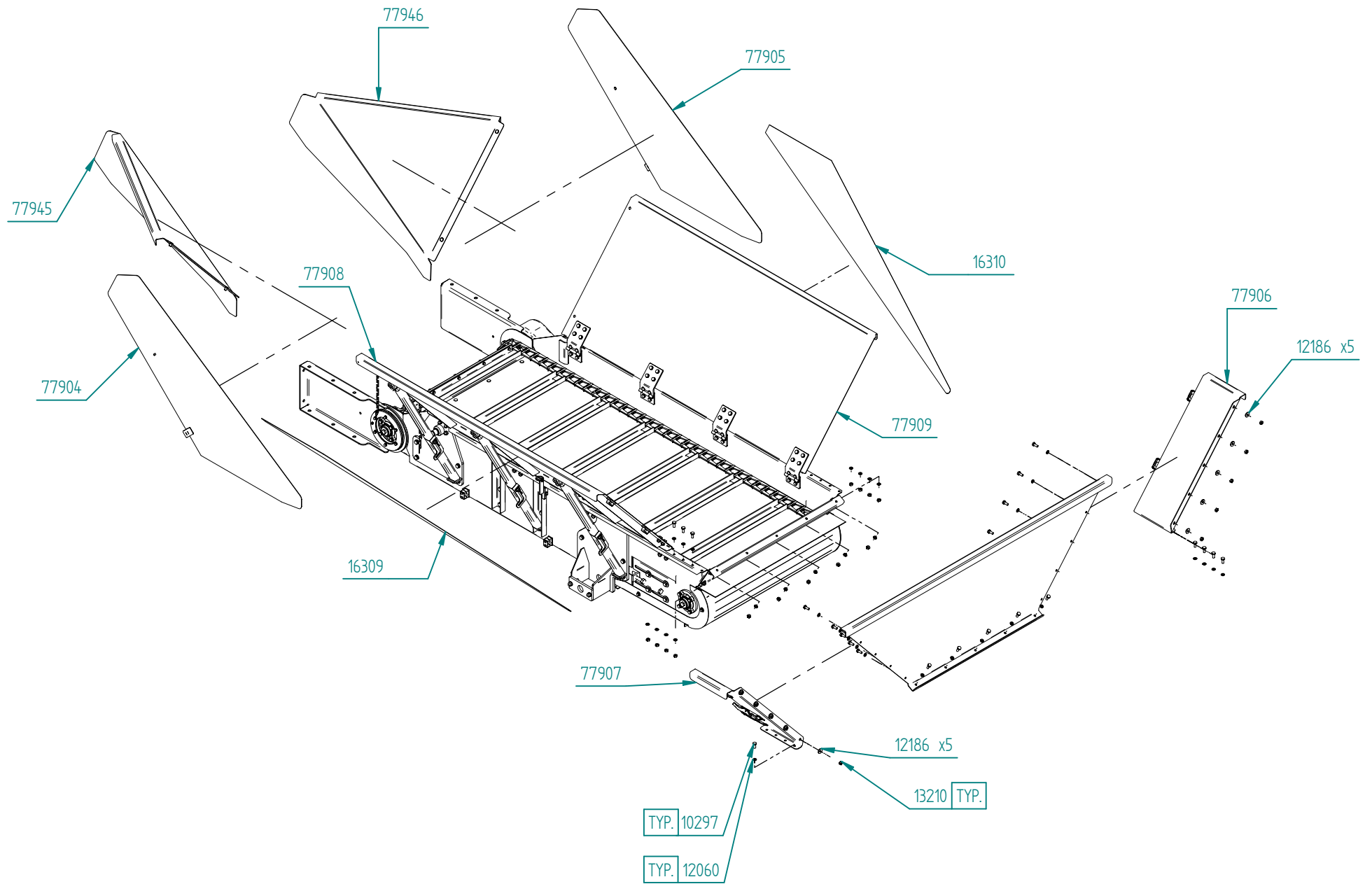

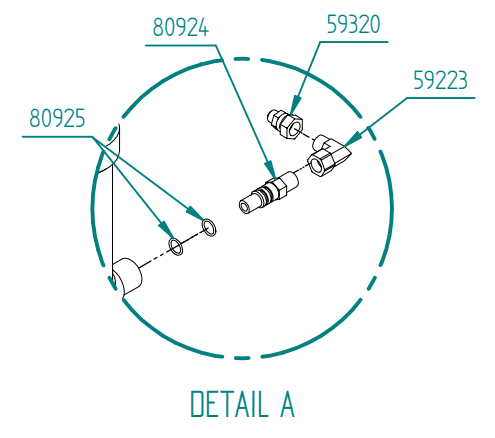
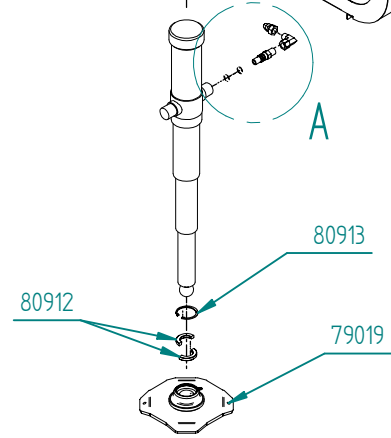
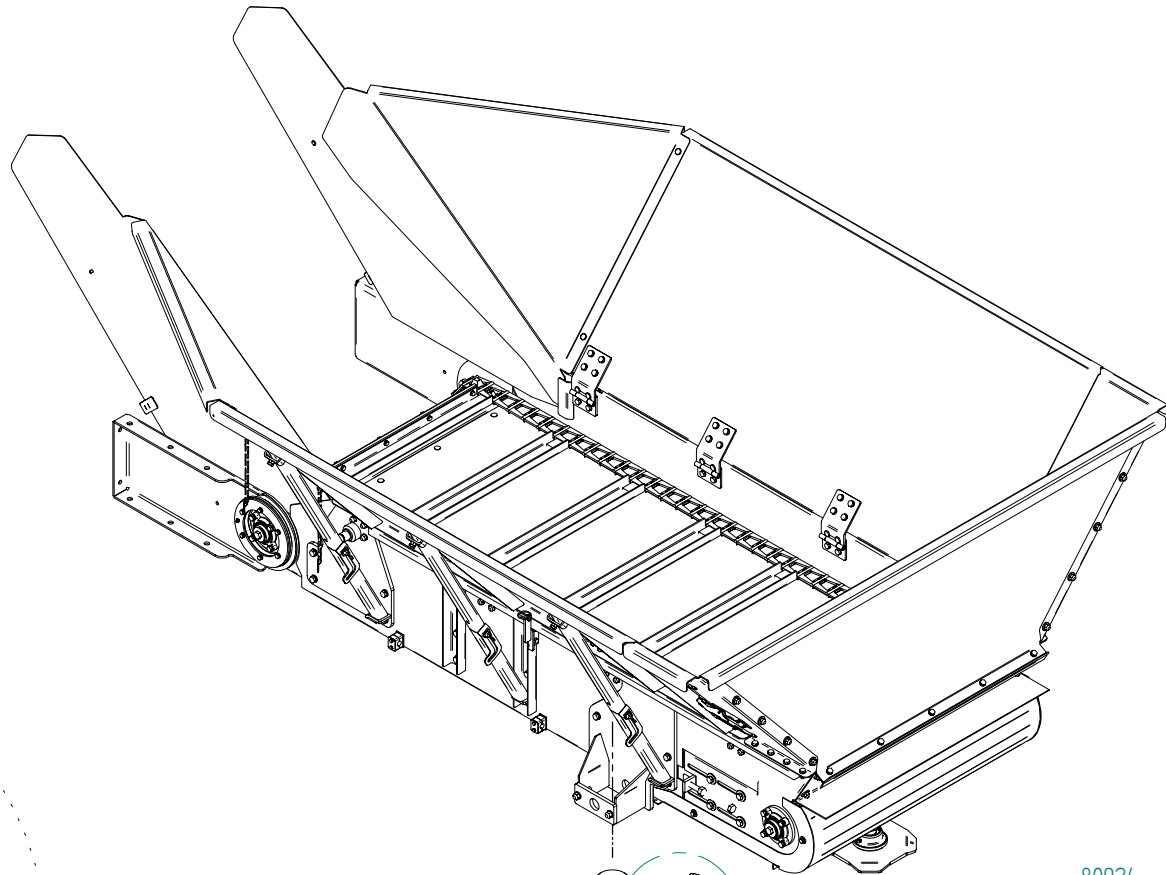
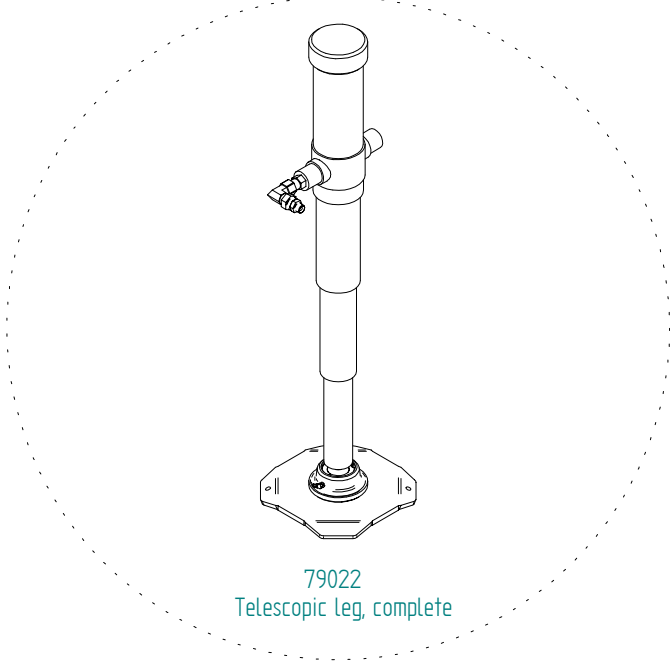
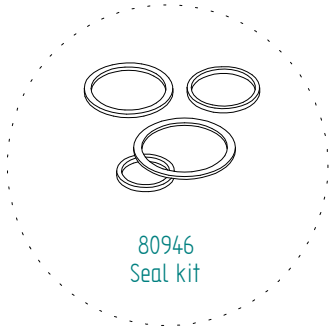

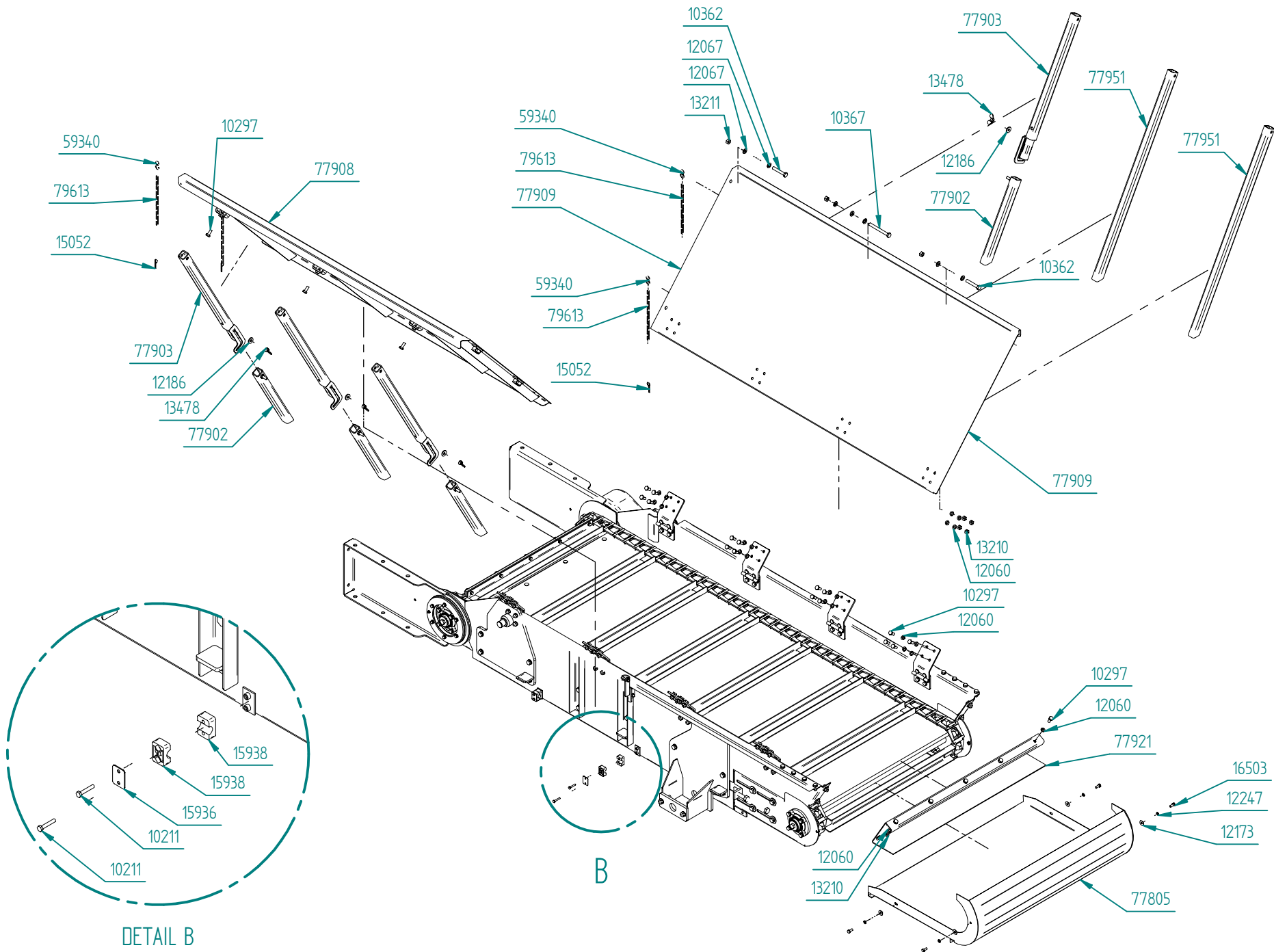

DETAIL B

B

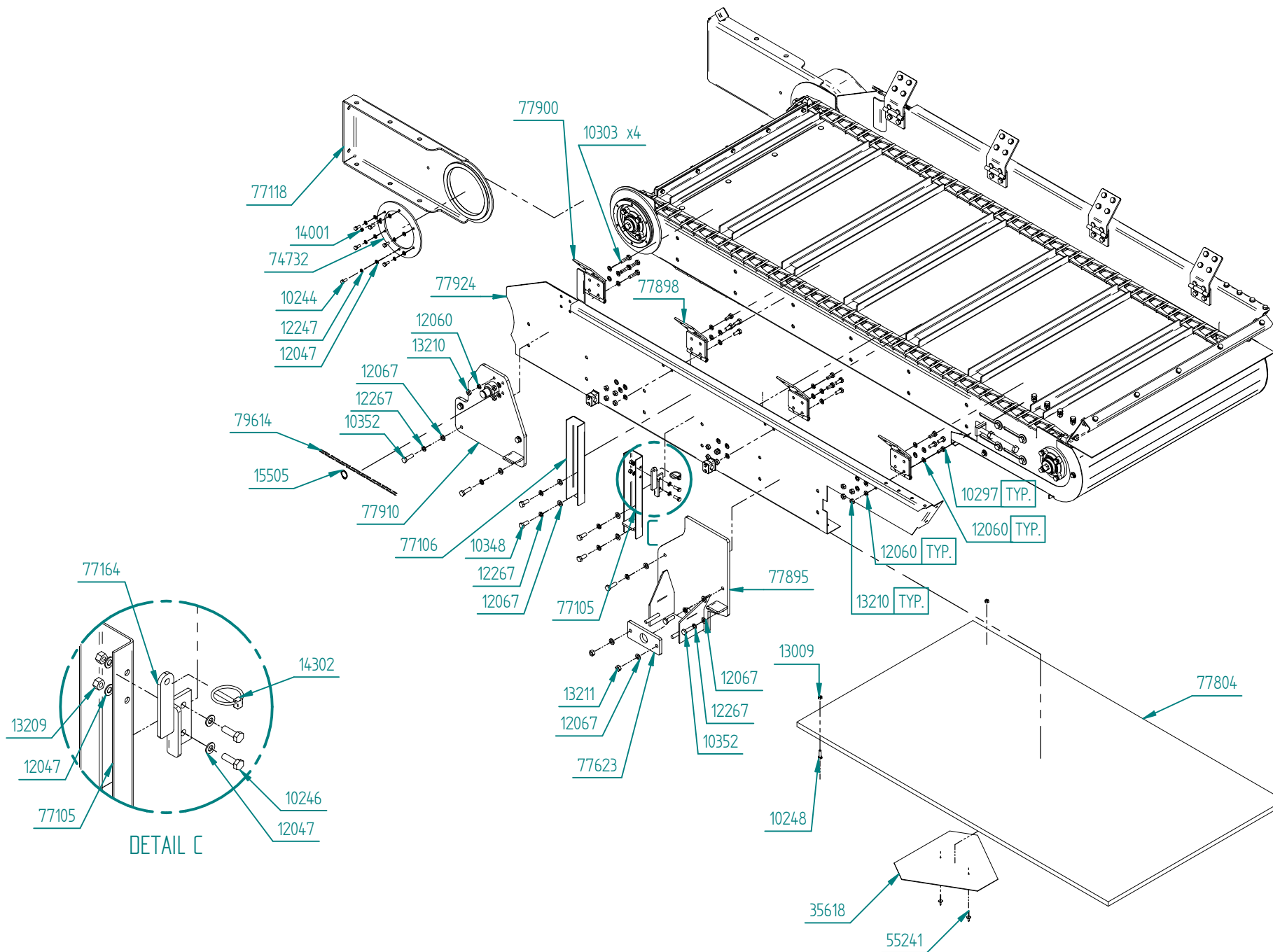

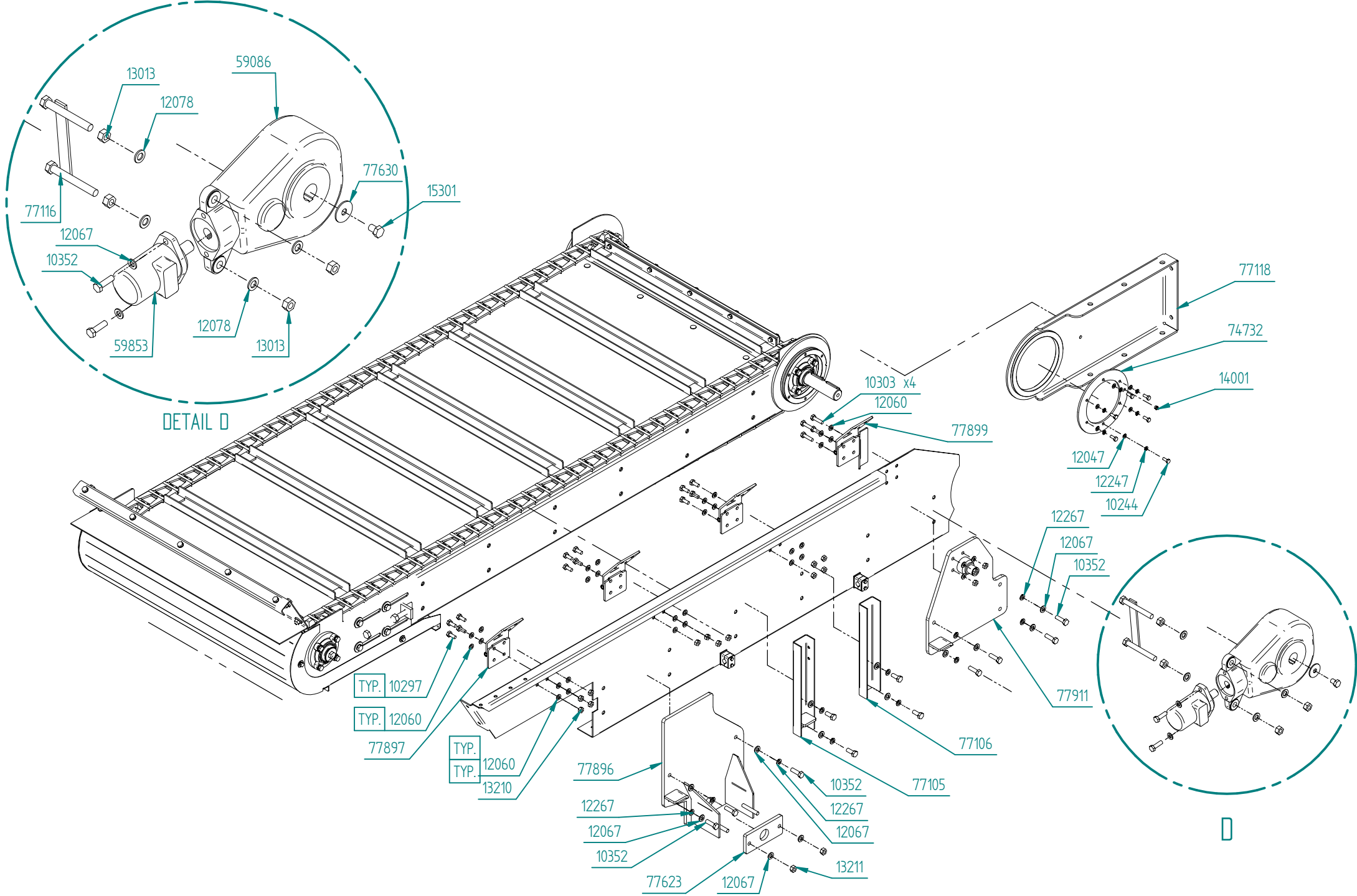

DETAIL D

D

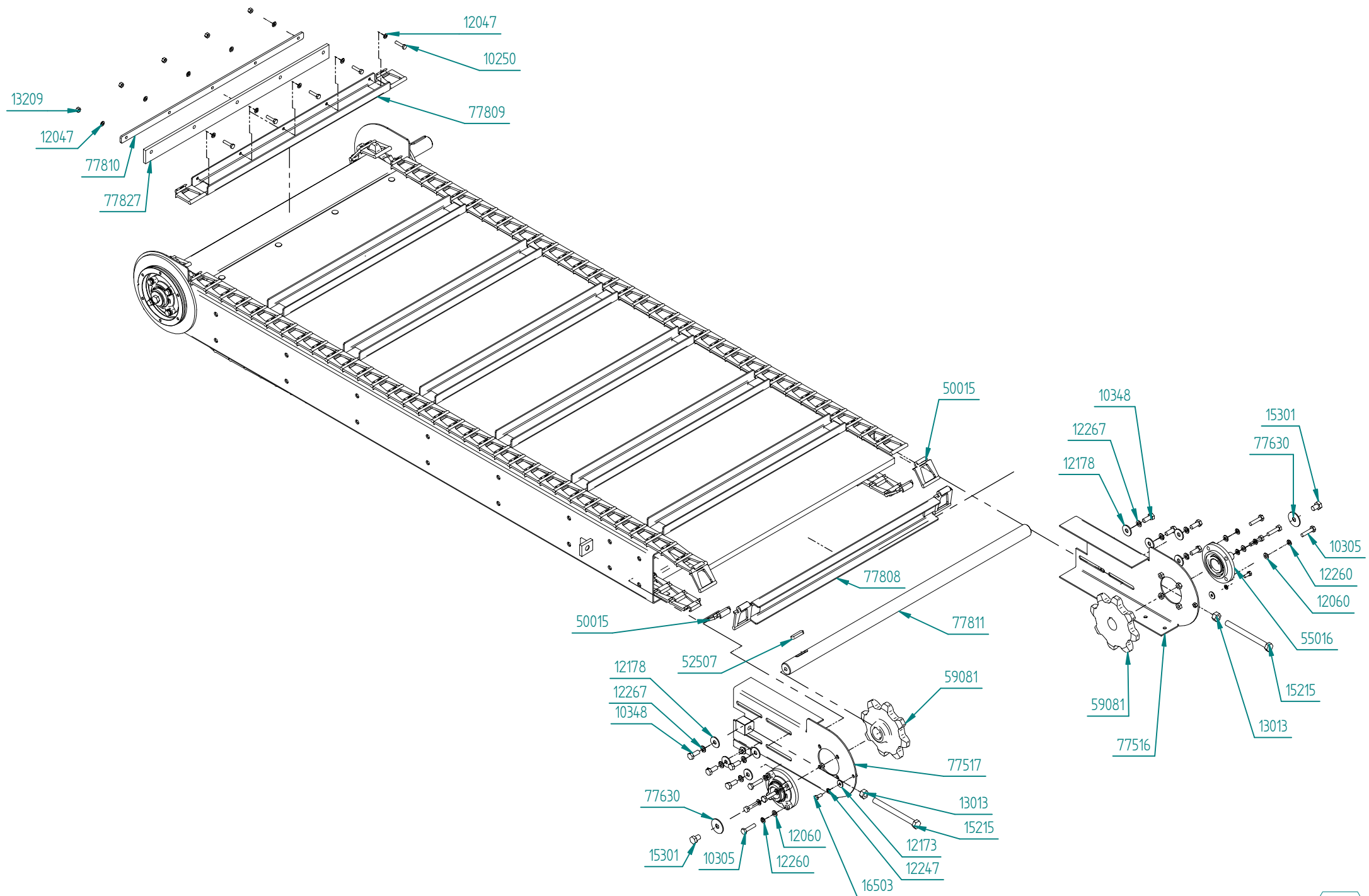

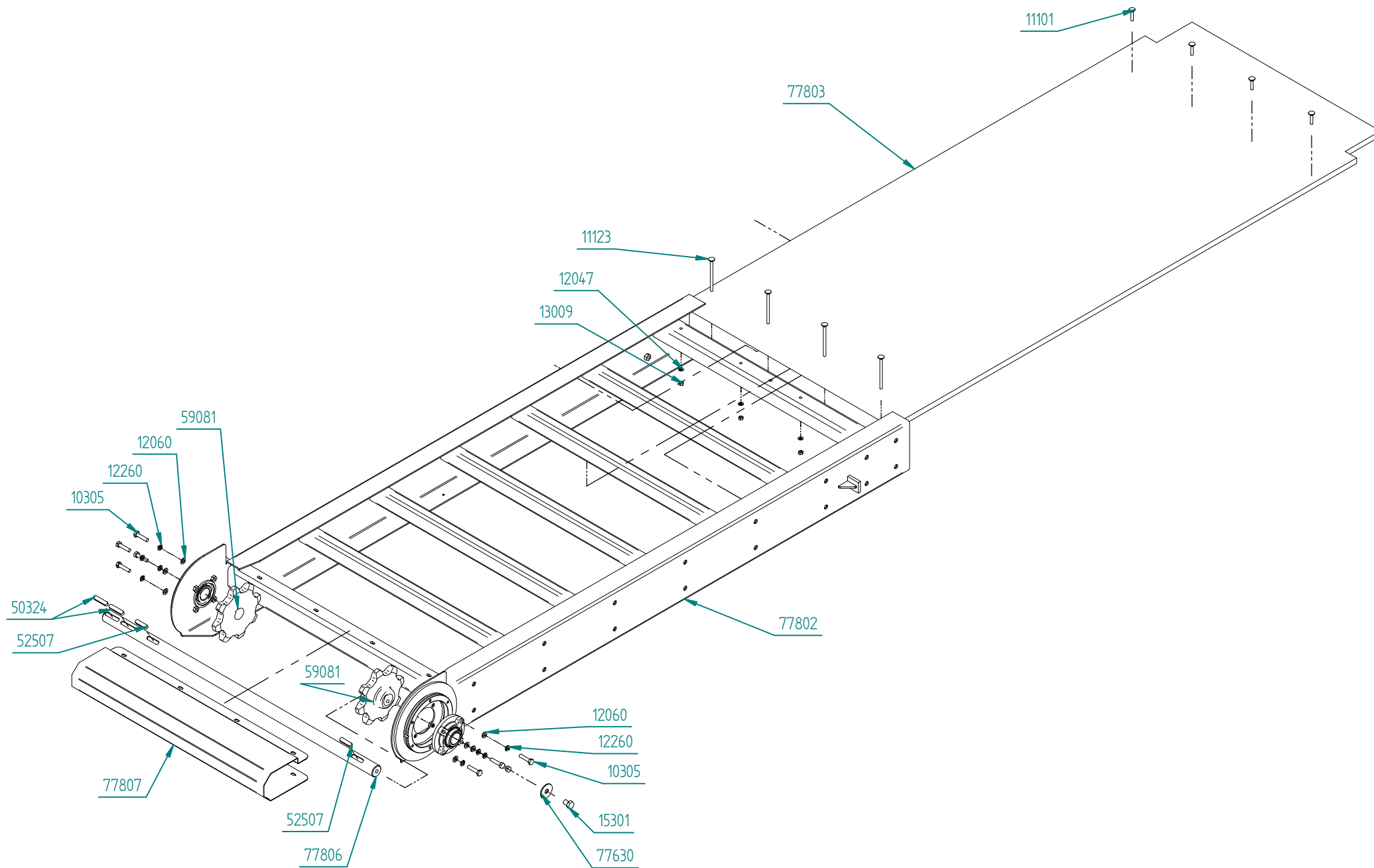

Part Number	Qty.	Title
10211	8	Bolt M6x35
10244	12	Bolt M8x20
10246	2	Bolt M8x25
10248	2	Bolt M8x30
10250	5	Bolt M8x35
10297	89	Bolt M10x25
10303	8	Bolt M10x40
10305	16	Bolt M10x45
10348	16	Bolt M12x30
10352	18	Bolt M12x40
10362	5	Bolt M12x75
10367	1	Bolt M12x120
11101	4	Lock head bolt M8x40
11123	4	Lock head bolt M8x120
12047	30	Washer M8
12060	182	Washer M10
12067	43	Washer M12
12078	4	Washer M16
12173	8	Washer $\varnothing 24/8,4 \times 2$
12178	8	Washer $\varnothing 37/13 \times 3$
12186	18	Washer $\varnothing 30/11 \times 2,5$
12247	16	Spring washer M8
12260	16	Spring washer M10
12267	32	Spring washer M12

Part Number	Qty.	Title
13009	10	Nut M8
13013	6	Nut M16
13209	7	Lock nut M8
13210	89	Lock nut M10
13211	10	Lock nut M12
13478	4	Wing nut M10
14001	2	Grease nipple 1/8" R
14302	1	Ear pin M6
15052	4	Hairpin M2,5
15215	2	Bolt M16x180, threaded to head
15301	4	Bolt M14x20
15505	2	Circlip A30x1,5
15936	4	Top plate for plastic tube clamp
15938	8	Tube clamp, plastic
16236	1	Sticker, left
16237	1	Sticker, right
16503	4	Bolt M8x20, black
35618	1	Warning triangle, large
50015	120	Chain link Kohlswa Ewart 78
50324	2	Key 12x8x60
52507	3	Key 12x8x50
55016	4	Bearing UCFEX08
55241	2	Pop Rivet $\varnothing 4,8 \times 14,5$
59081	4	Sprocket

Part Number	Qty.	Title
59086	1	Gir RT 200
59223	2	Elbow
59320	2	Transition
59340	4	S-hook 3 mm
59853	1	Motor BG80 NC25
74732	2	Locking washer for hinge
77105	2	U-profile 2, cover
77106	2	U-profile 1, cover
77116	1	Gear bracket
77118	2	Hinge plate
77164	1	Cover lock bracket
77516	1	Tightener, right bottom
77517	1	Tightener, left bottom
77623	2	Fastener, telescopic leg
77630	4	Washer $\varnothing 50/15 \times 3$
77802	1	Bottom frame
77803	1	Visaform bottom plate, upper
77804	1	Visaform plate bottom
77805	1	Spill tray
77806	1	Drive shaft, feed hopper
77807	1	Protection cover
77808	14	Carrier
77809	1	Carrier with holes for scraper
77810	1	Fixing list carrier

Part Number	Qty.	Title
77811	1	Shaft tightening side
77827	1	Scraper rubber
77895	1	Bracket telescopic leg left
77896	1	Bracket telescopic leg right
77897	3	Hinge, right cover
77898	3	Hinge, left cover
77899	1	Hinge front, right cover
77900	1	Hinge front, left cover
77901	1	Side cover lock
77902	4	Side cover support, bottom
77903	4	Side cover support, upper
77904	1	Middle plate, left
77905	1	Middle plate, right feeding table
77906	1	End cover upper right
77907	1	End cover upper left
77908	1	Side cover, upper left
77909	1	Side cover, upper right
77910	1	Cylinder bracket, left
77911	1	Cylinder bracket, right
77921	1	End cover bottom
77924	1	Side bottom cover, left
77925	1	Side bottom cover, right
77926	1	End cover, upper
77945	1	Middle plate, left

Part Number	Qty.	Title
77946	1	Middle plate, right
77951	2	Side cover support, undivided
79019	2	Foot plate, telescopic legs
79022	1	Telescopic leg, complete
79613	4	Chain 3 mm long chained
79614	2	Chain 3 mm long chained
80912	4	Flange
80913	2	Seeger ring J65
80924	2	Nipple
80925	4	O-ring
80946	1	Seal kit

82489
Standard

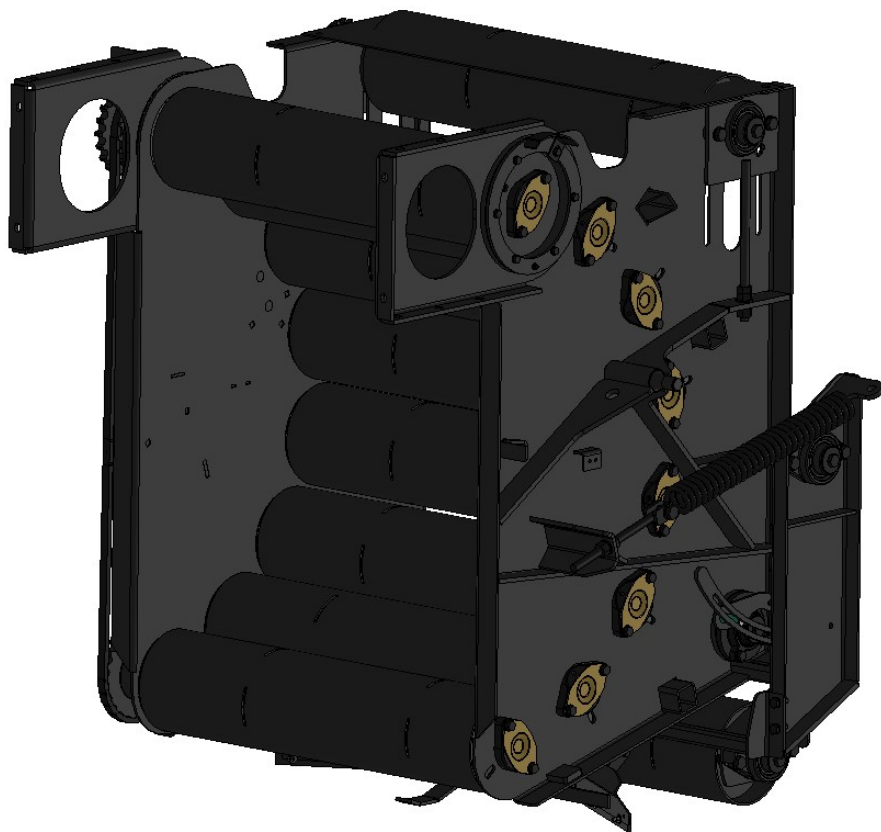

82490
Hardox

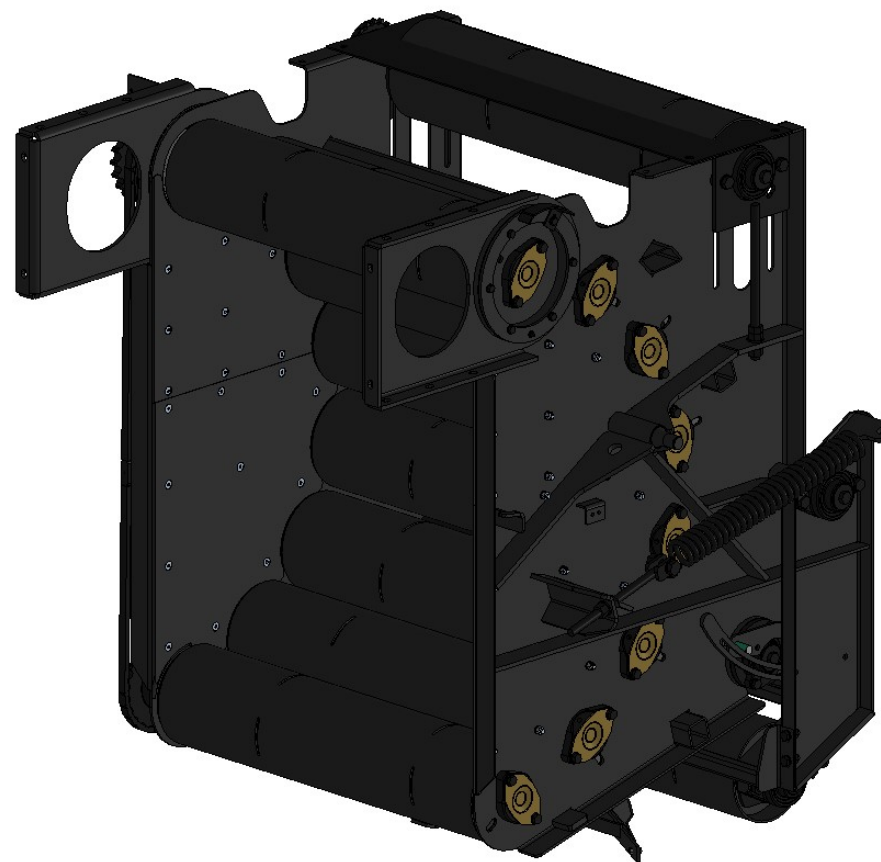

Standard

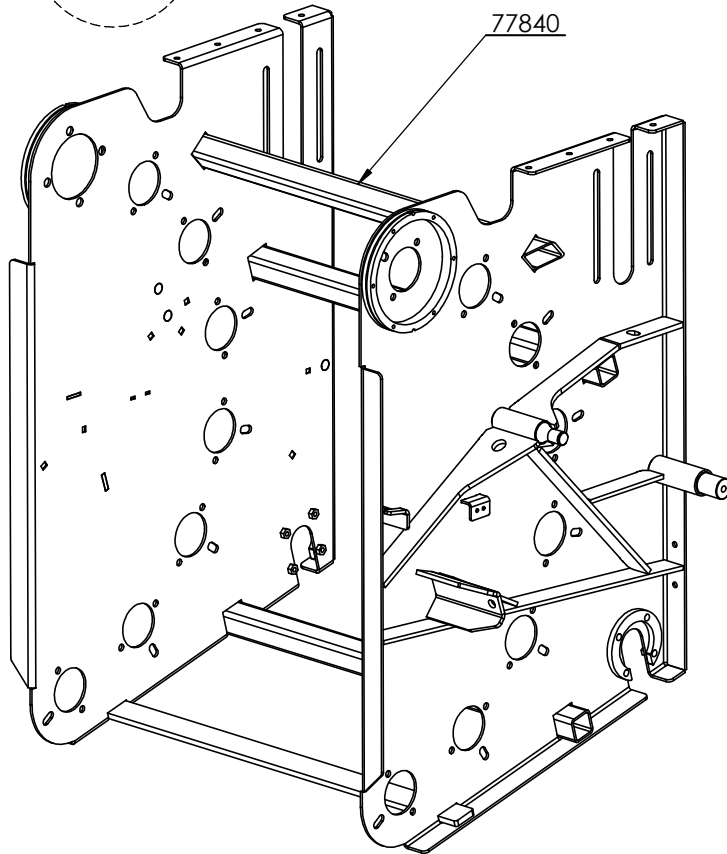

Hardox

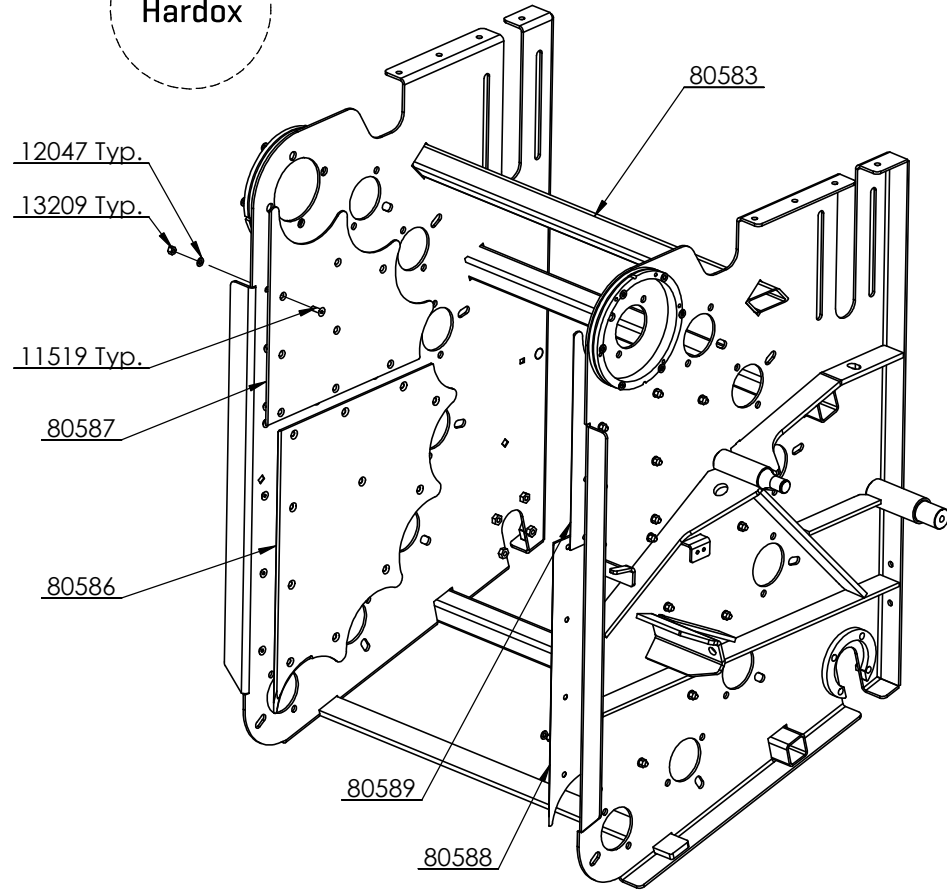

Part number	Qty	Description
77840	1	Weldment parts, front chamber, MC850

Part number	Qty	Description
11519	38	Countersunk bolt M8x20
12047	54	Washer 8,4 DIN 125A -140HV FZV
13209	42	Lock nut M8
80586	1	Wear plate front chamber left lower
80587	1	Wear plate front chamber left upper
80588	1	Wear plate front chamber right lower
80589	1	Wear plate front chamber right upper



Part number	Qty	Description
59259	1	Key 18x11x60
77835	15	Winding protection
77836	1	Winding protection
77838	1	Chamber side front, left, MC850
77839	1	Side plate, front chamber, right, MC850
77818	5	Roller 1-6, 9-14
77816	1	Roller 16 and 17
77817	2	Roller 7, 8 and 15

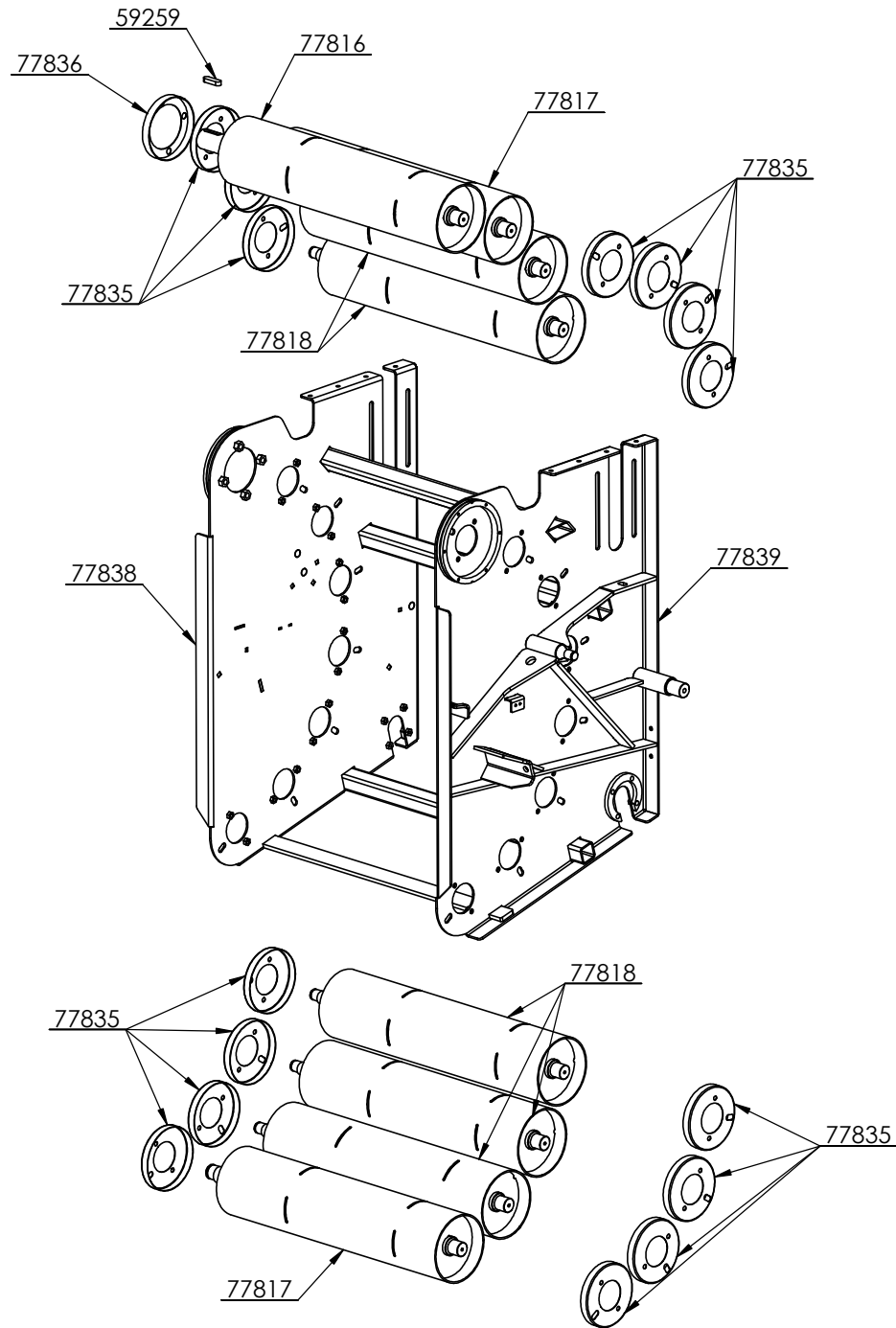

Part number	Qty	Description
10299	8	Bolt M10 x 30 DIN 933 8.8 FZV
12060	24	Washer 10,5 DIN 125A -140HV FZV
13210	8	Lock nut M10
77121	4	Nut plate, tightener front
77856	1	Stiffening tube
77821	1	Roll tightener with drive
77822	1	Roll tightener, small diameter
63791	1	Key A10 x 8 x 30

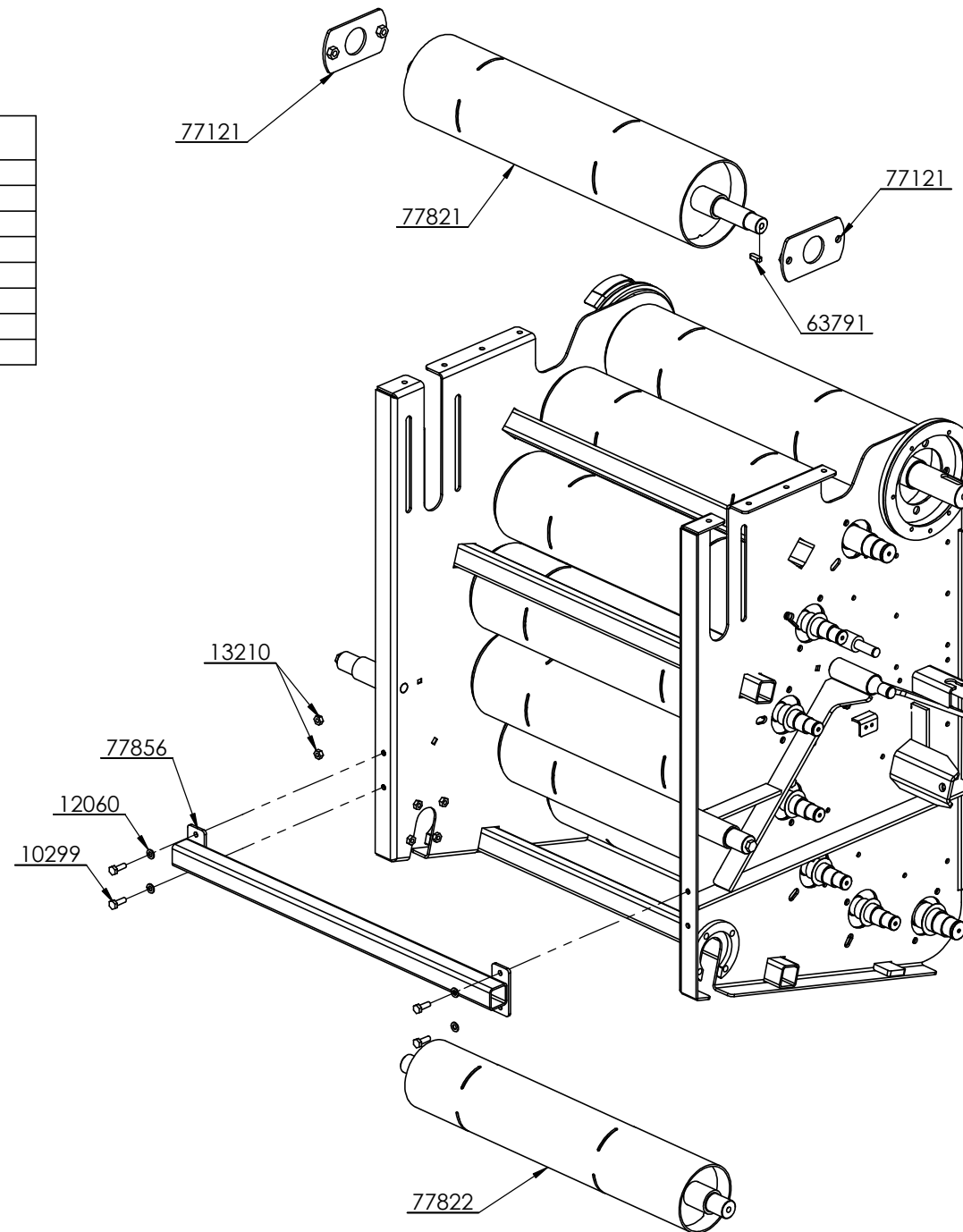

Part number	Qty	Description
10246	16	Bolt M8 x 25 DIN 933 8.8 FZV
10310	8	Bolt M10 x 60 DIN 931 8.8 FZV
10402	12	Bolt M14x50
12047	16	Washer 8,4 DIN 125A -140HV FZV
12060	24	Washer 10,5 DIN 125A -140HV FZV
12072	16	Washer 15 DIN 125A -140HV FZV
12078	16	Washer 17 DIN 125A -140HV FZV
13013	6	Nut M16 DIN 934 Cl.8 FZV
13213	7	Lock nut M16
14001	2	Grease nipple 1/8" R
15301	8	Bolt M14x20
15903	30	Bolt M10x45
55016	2	Bearing UCFCX08
57508	13	Bearing housing ø44 innv.
57576	8	Plain bearing Ø40/44x55x40
59025	6	Bearing UCFL208
74755	8	Bearing housing cover
77122	2	Tightening mechanism
77567	1	Stop bow
77630	8	Washer ø50/15x3
77859	1	Hinge plate right
77965	2	Locking hinge ring
79454	1	Plate, top, chamber

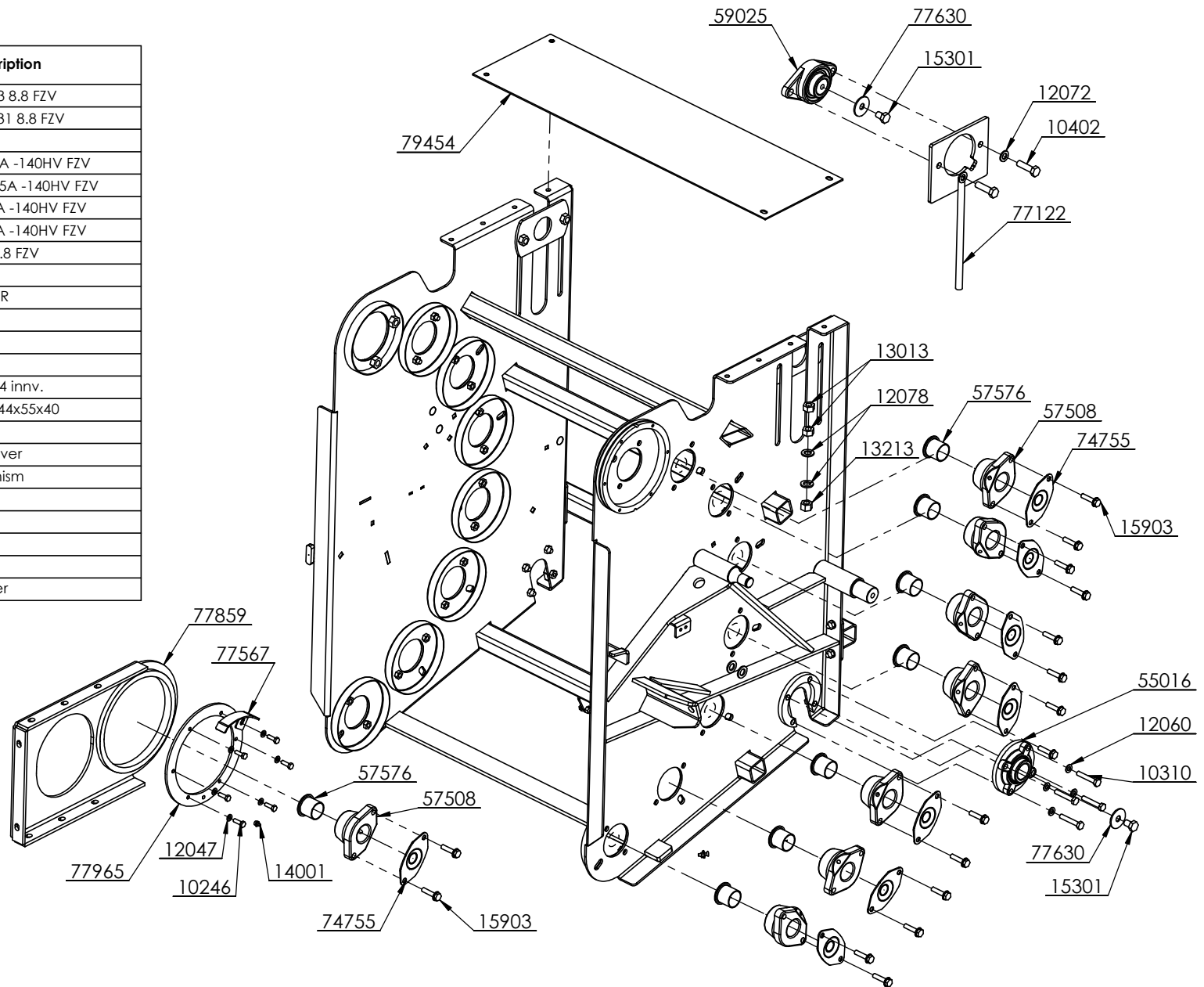

Part number	Qty	Description
10246	16	Bolt M8 x 25 DIN 933 8.8 FZV
10310	8	Bolt M10 x 60 DIN 931 8.8 FZV
10402	12	Bolt M14x50
10485	1	Bolt M16 x 30 DIN 933 8.8 FZV
10497	4	Bolt M16 x 65 DIN 931 8.8 FZV
12047	16	Washer 8,4 DIN 125A -140HV FZV
12060	24	Washer 10,5 DIN 125A -140HV FZV
12072	16	Washer 15 DIN 125A -140HV FZV
12078	16	Washer 17 DIN 125A -140HV FZV
12088	6	Washer 21 DIN 125A -140HV FZV
12182	1	Washer ø85/17x3
13013	6	Nut M16 DIN 934 Cl.8 FZV
13213	7	Lock nut M16
13215	1	Lock nut M20
14001	2	Grease nipple 1/8" R
15207	1	Bolt M20 x 80 DIN 933 8.8 FZV
15301	8	Bolt M14x20
15505	5	Circlip A30x1,5
15522	1	Circlip A20x1,75
15801	5	Washer ø50/30x2
15803	1	Washer ø20/32x1
15903	30	Bolt M10x45
19412	4	Chain sprocket
19413	2	Sprocket
19414	1	Sprocket
50512	2	Circlip A40x1,75
55016	2	Bearing UCFCX08
55459	1	Bearing 6304 2RS
57508	13	Bearing housing ø44 innv.
57512	2	Bearing housing ø55 innv.
57558	1	Spring, chain tightener
57577	10	Plain bearing Ø40/44x55x25
57578	4	Plain bearing Ø50/55x65x30
59025	6	Bearing UCFL208
59849	1	Bearing
74756	7	Shim ø60/40x1
74758	2	Washer ø70/50x1
75013	1	Protection tube chain tightener
77061	1	Chain tightener
77122	2	Tightening mechanism
77174	1	Chain tightener, front
77617	1	Sprocket
77625	1	Sprocket, double drive, tightening
77630	8	Washer ø50/15x3
77851	1	Flexible coupling, inner
77965	2	Locking hinge ring
77995	1	Shims

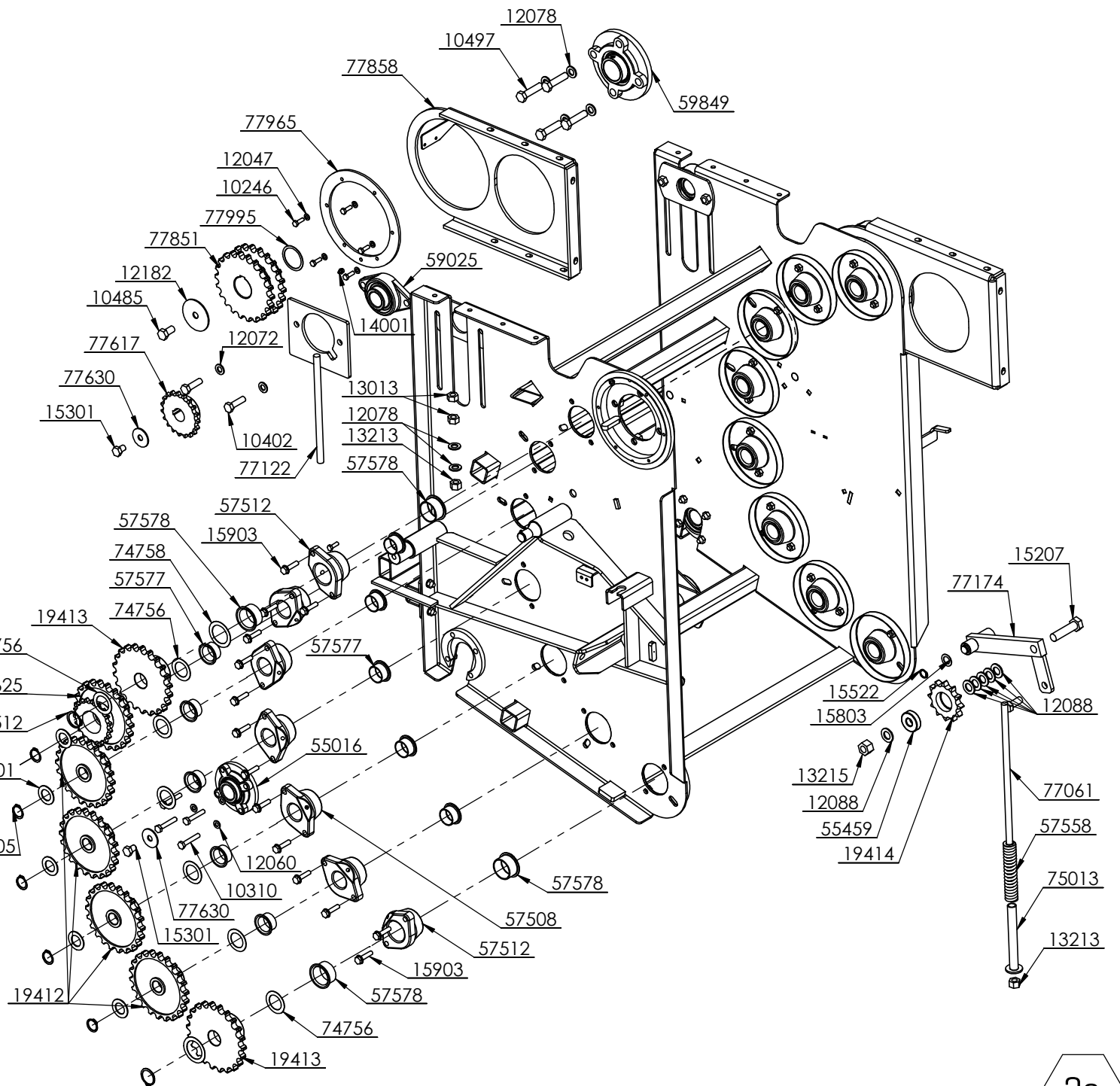

Part number	Qty	Description
10246	16	Bolt M8 x 25 DIN 933 8.8 FZV
10299	8	Bolt M10 x 30 DIN 933 8.8 FZV
10402	12	Bolt M14x50
10493	2	Bolt M16 x 50 DIN 933 8.8 FZV
11504	8	Countersunk bolt M6x20
12047	16	Washer 8,4 DIN 125A -140HV FZV
12060	24	Washer 10,5 DIN 125A -140HV FZV
12072	16	Washer 15 DIN 125A -140HV FZV
12078	16	Washer 17 DIN 125A -140HV FZV
12159	8	Washer 6,4 x 18 x 1,6 DIN 9021 FZV
13013	6	Nut M16 DIN 934 Cl.8 FZV
13208	8	Lock nut M6
13209	4	Lock nut M8
13210	8	Lock nut M10
13212	4	Lock nut M14
13213	7	Lock nut M16
15301	8	Bolt M14x20
58414	1	Chain lock 1"
59025	6	Bearing UCFL208
59263	1	Wearing plastic scraper
59570	1	Chain, front chamber
59829	1	Chain 3/4"
59830	1	Chain lock 3/4"
77121	4	Nut plate, tightener front
77557	2	Scraper link
77630	8	Washer ø50/15x3
77852	1	Belt tightener front
77853	1	Scraper suspension, front
77858	1	Hinge plate, left
77859	1	Hinge plate right
77883	1	Scraper plow front
77820	1	Roll tightener 1
80705	2	Spring
80706	2	Tightening rod, springs, belt tightener

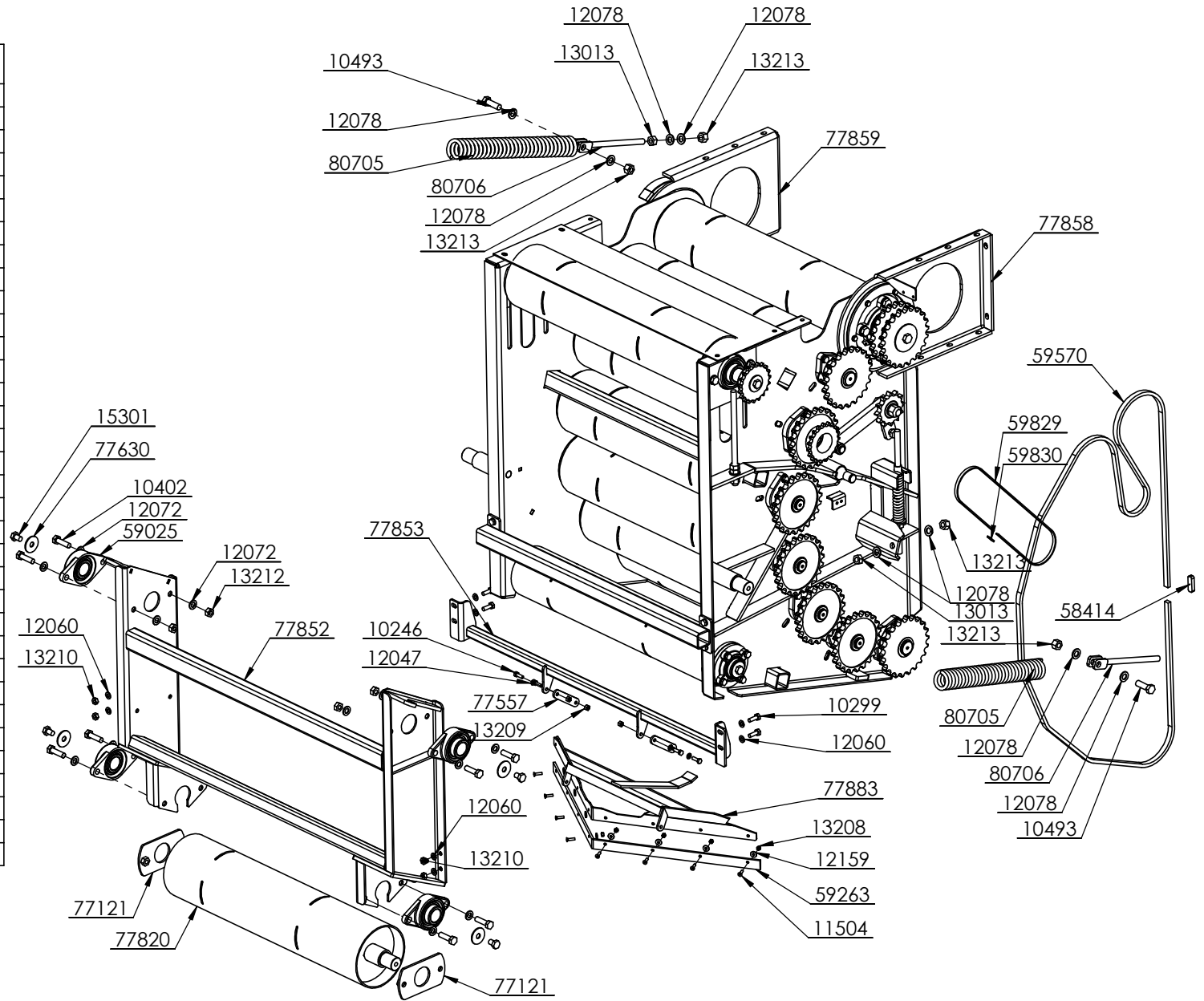

Part number	Qty	Description
82430	1	Sensor bracket MC850 Flex
59005	1	Inductive transducer
82429	1	Sensor plate MC850 Flex
82593	2	Spacer

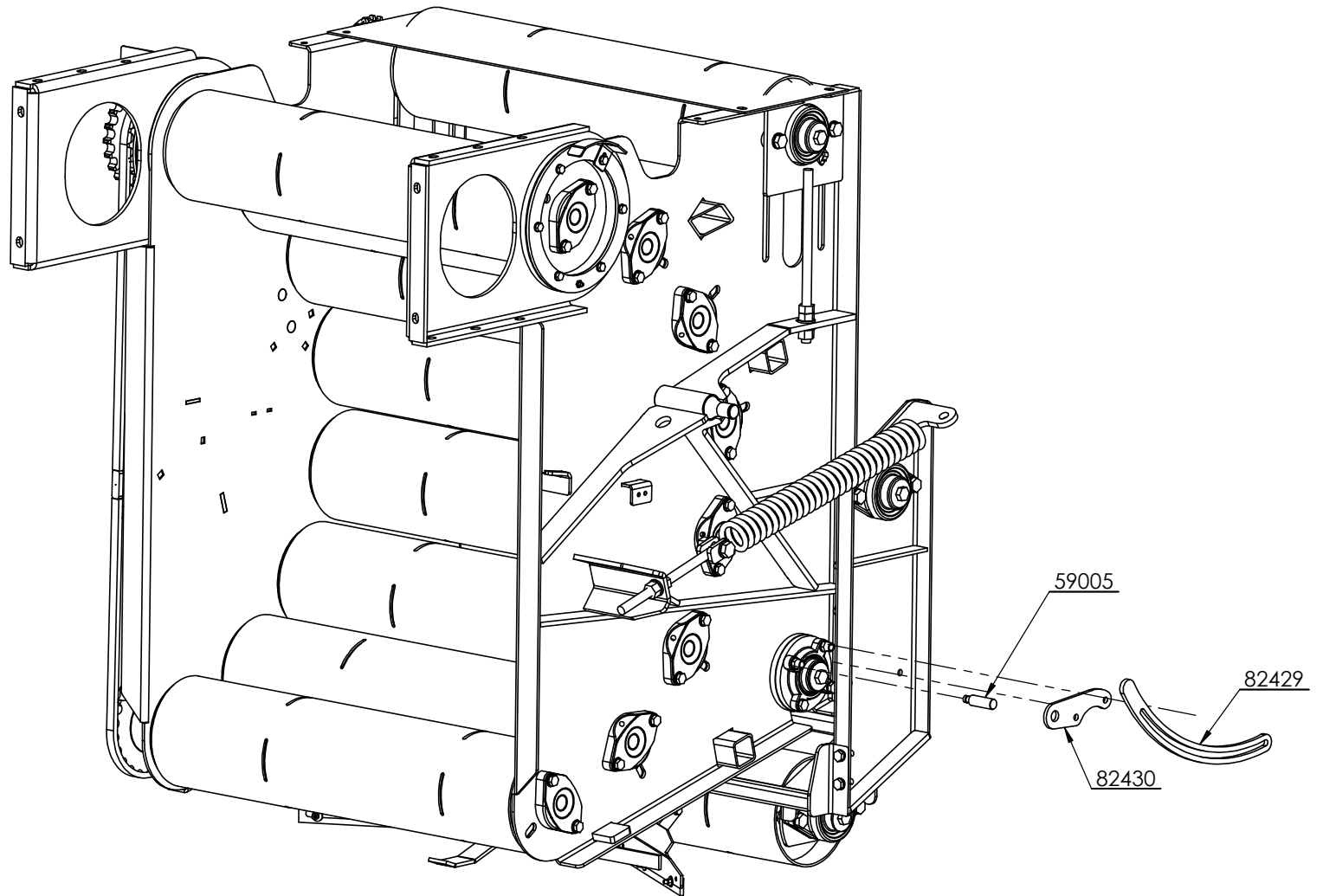

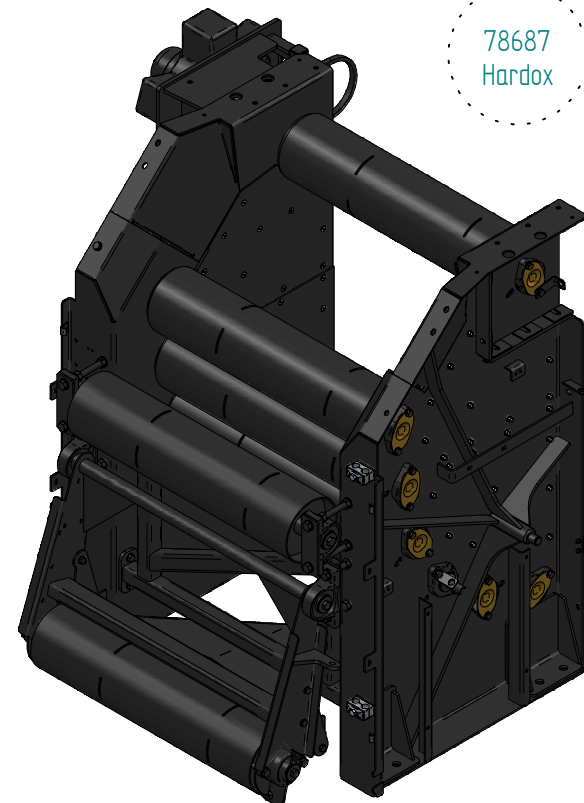
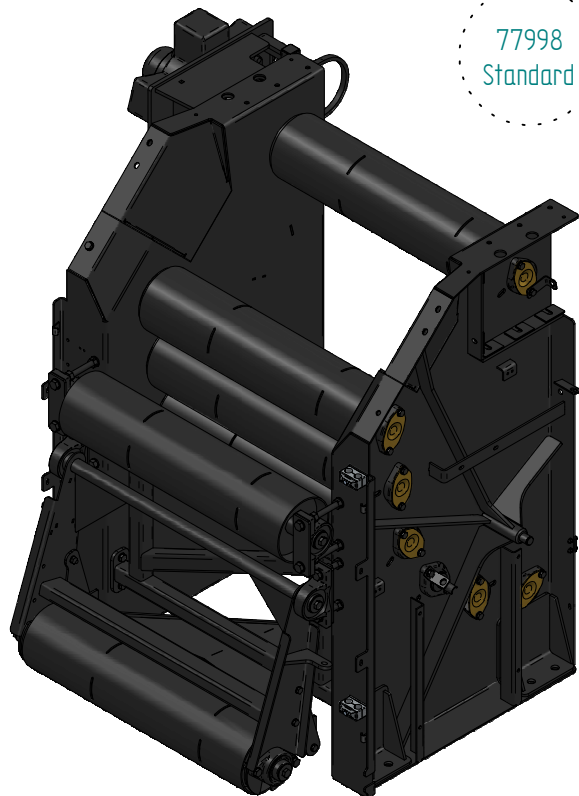

Standard

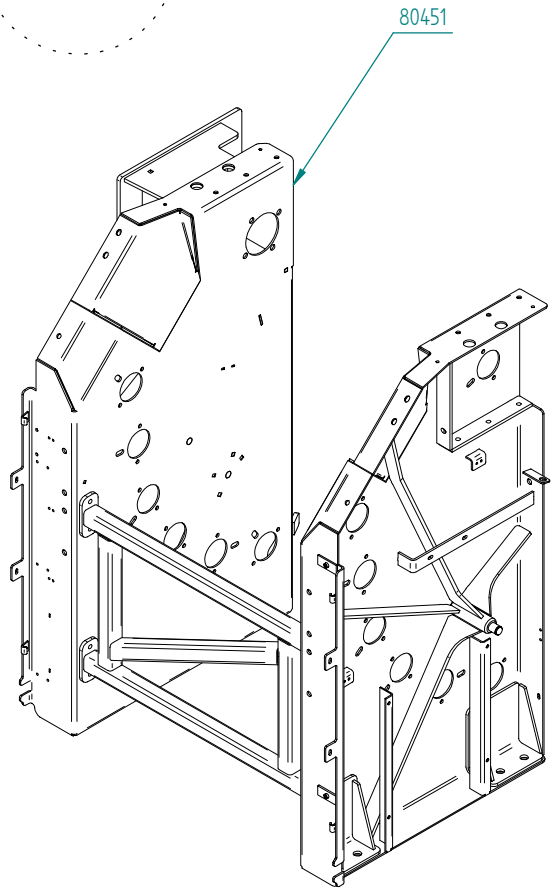

Hardox

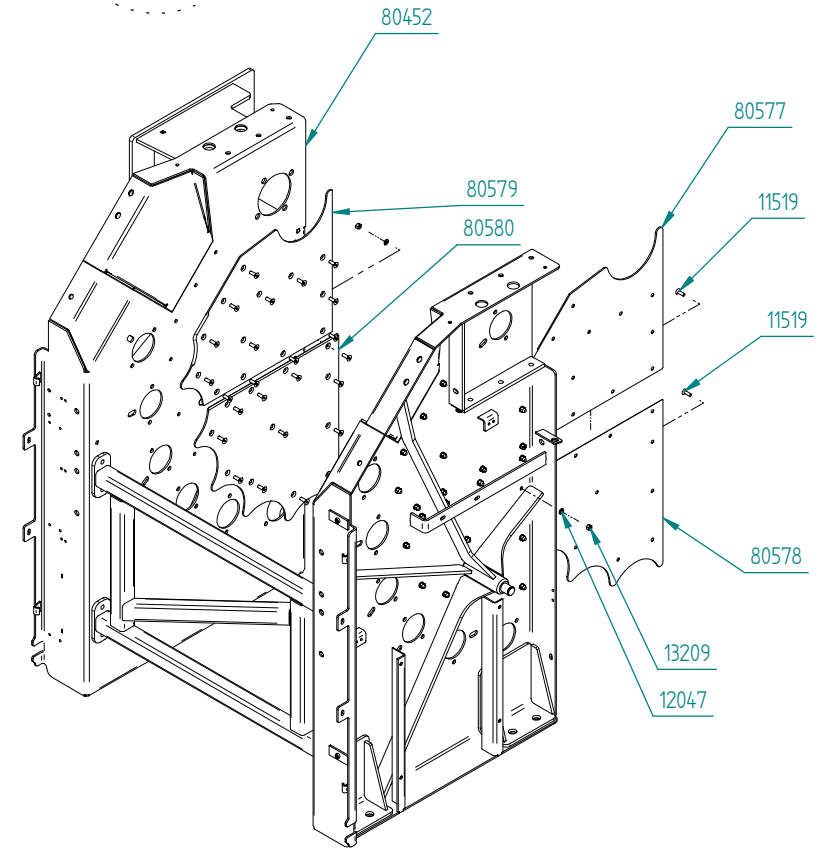

Chamber walls

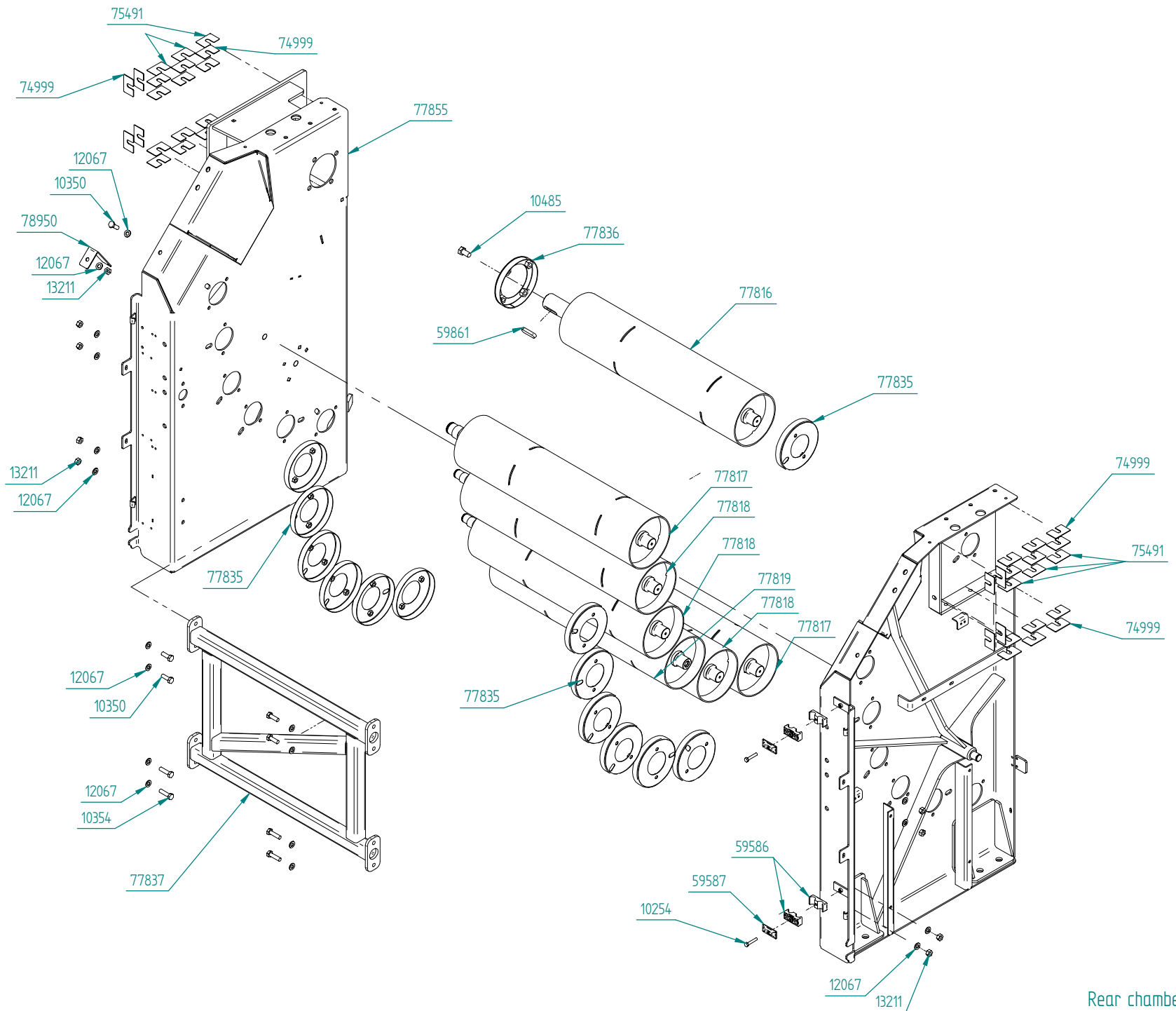

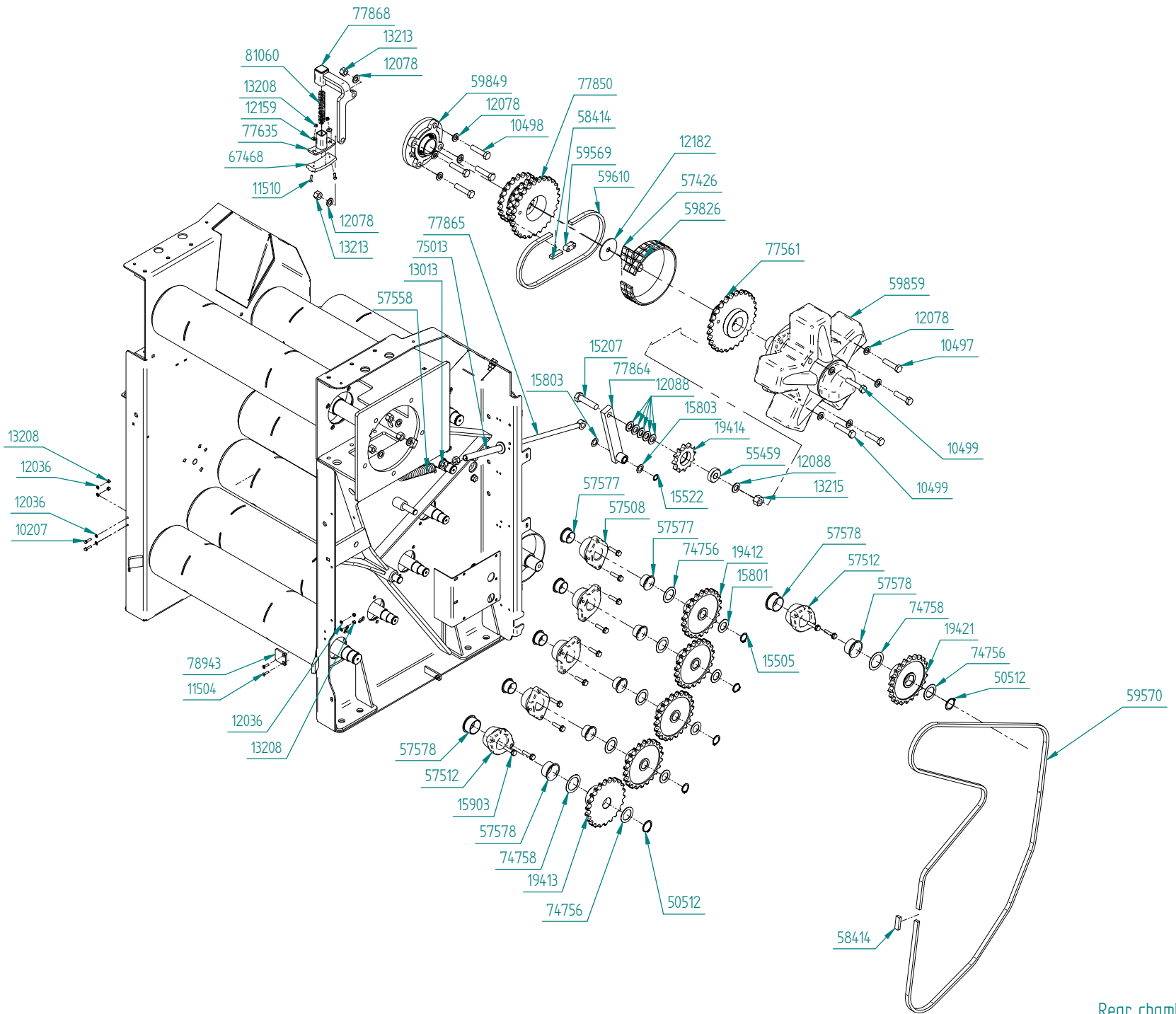

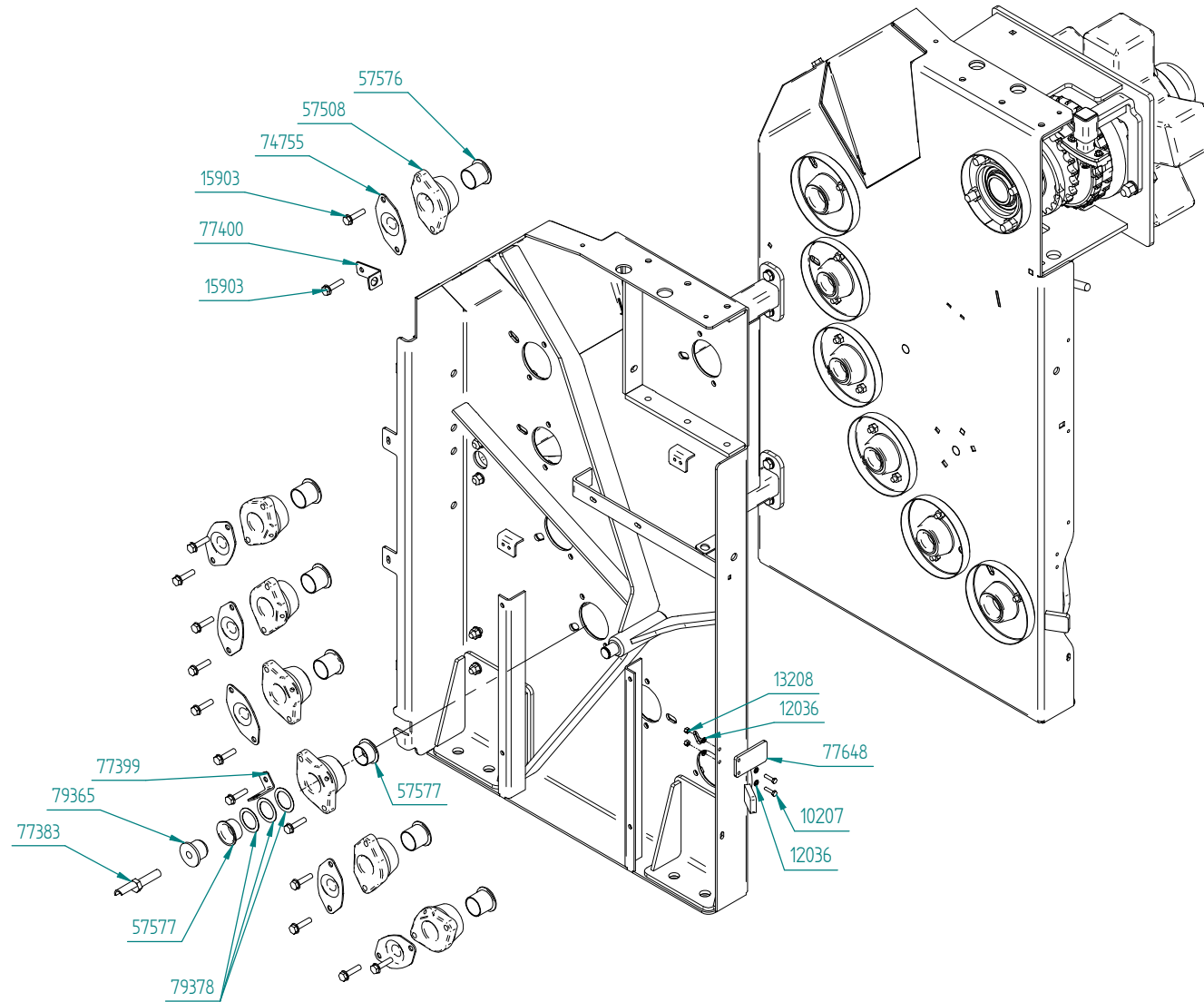

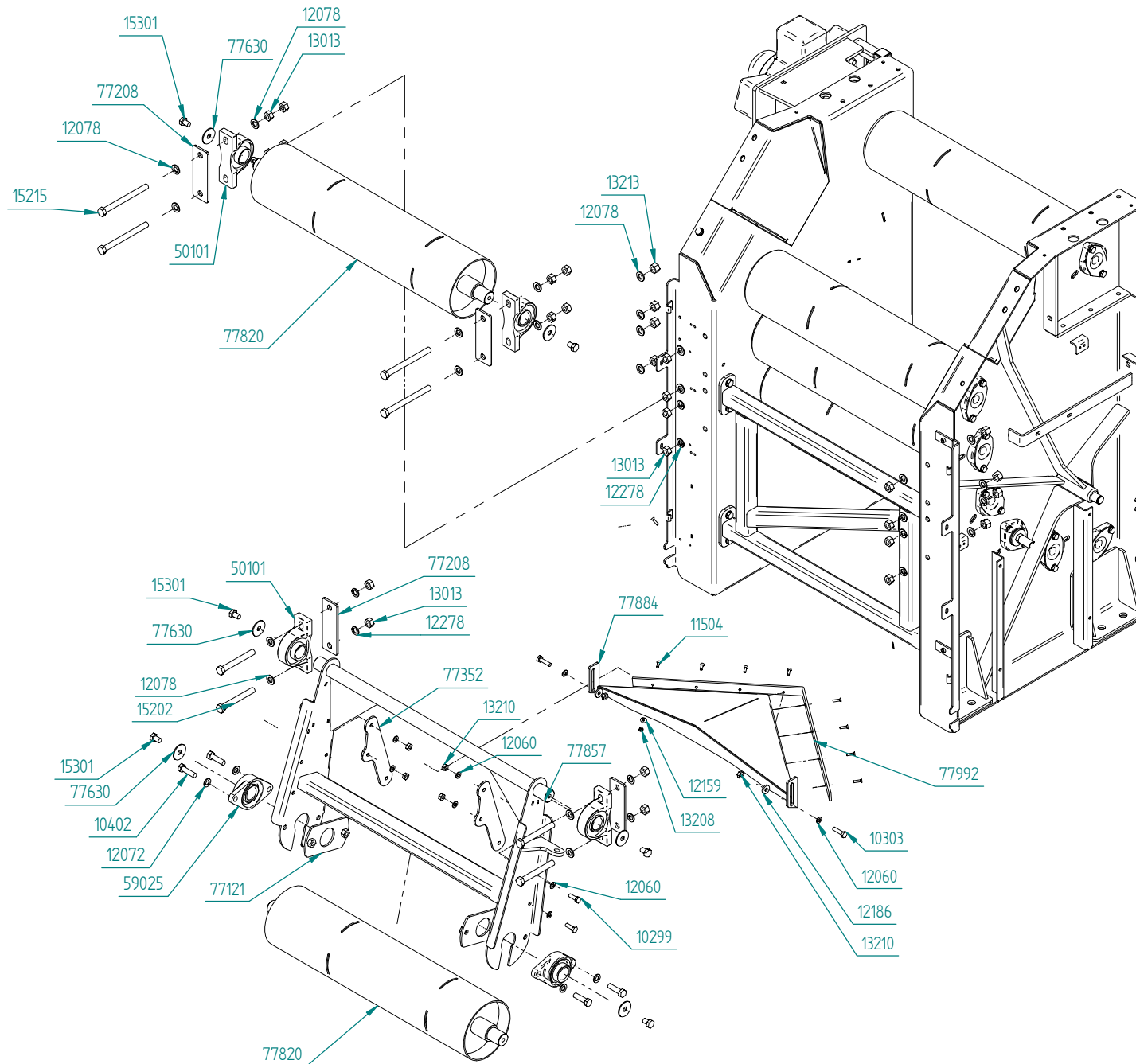

Part Number	Qty.	Title
10207	2	Bolt M6x25, threaded to head
10254	2	Bolt M8x45
10299	4	Bolt M10x30
10303	2	Bolt M10x40
10350	5	Bolt M12x35
10354	4	Bolt M12x45
10402	4	Bolt M14x50
10485	1	Bolt M16x30, threaded to head
10497	3	Bolt M16x65
10498	4	Bolt M16x70
10499	2	Bolt M16x75
11504	13	Countersunk bolt M6x20
11519	50	Countersunk bolt M8x20
12036	6	Washer M6
12047	50	Washer M8
12060	10	Washer M10
12067	18	Washer M12
12072	4	Washer M14
12078	38	Washer M16
12088	6	Washer M20
12159	10	Washer \varnothing 18/6,4
12182	1	Washer \varnothing 85/17x3
12186	2	Washer \varnothing 30/11x2,5
12278	8	Spring washer M16

Part Number	Qty.	Title
13013	22	Nut M16
13208	14	Lock nut M6
13209	50	Lock nut M8
13210	6	Lock nut M10
13211	9	Lock nut M12
13213	13	Lock nut M16
13215	1	Lock nut M20
15202	4	Bolt M16x130, threaded to head
15207	1	Bolt M20x80, threaded to head
15215	4	Bolt M16x180, threaded to head
15301	6	Bolt M14x20
15505	4	Circlip A30x1,5
15522	1	Circlip A20x1,75
15801	4	Washer \varnothing 50/30x2
15803	2	Washer \varnothing 20/32x1
15903	26	Bolt M10x45
19412	4	Sprocket
19413	1	Sprocket
19414	1	Sprocket
19421	1	Sprocket
50101	4	Bearing UCP208
50512	2	Circlip A40x1,75
55459	1	Bearing 6304 2RS
57426	1	Chain duplex, lock

Part Number	Qty.	Title
57508	11	Bearing housing \varnothing 44 innv.
57512	2	Bearing housing \varnothing 55 innv.
57558	1	Spring, chain tightener
57576	6	Plain bearing \varnothing 40/44x55x40
57577	10	Plain bearing \varnothing 40/44x55x25
57578	4	Plain bearing \varnothing 50/55x65x30
58414	2	Chain lock 1"
59025	2	Bearing UCFL208
59569	2	Chain half link 1"
59570	1	Chain 1", back chamber
59586	2	Pipe clamp double 22 mm
59587	2	Top plate for double clamp 20-25
59610	1	Chain 1" x 39 ledd
59826	1	Chain duplex 1"
59849	1	Bearing
59859	1	Motor, radial piston
59861	1	Key 16x10x60
67468	1	Wearing plastic, chain tightener, short chain
74755	6	Bearing housing cover
74756	6	Shim \varnothing 60/40x1
74758	2	Washer \varnothing 70/50x1
74999	32	Shims 70x45x2
75013	1	Protection tube chain tightener
75491	6	Shims 70x45x1

Part Number	Qty.	Title
77121	2	Nut plate, tightener front
77208	4	Feeding plate, tightening bearing
77352	2	Scraper fastener, rear
77383	1	Counting screw
77399	1	Sensor bracket, chamber speed
77400	1	Sensor bracket, chamber open
77561	1	Flexible coupling, outer
77630	6	Washer $\varnothing 50/15 \times 3$
77635	1	Chain tightener, glider
77648	1	Shims, chamber opening, 6mm
77816	1	Roller 16 and 17
77817	2	Roller 7, 8 and 15
77818	3	Roller 1-6, 9-14
77819	1	Roller 5
77820	2	Roll tightener 1
77835	13	Winding protection
77836	1	Winding protection
77850	1	Flexible coupling, inner
77857	1	Belt tightener, rear
77864	1	Chain tightener, rear
77865	1	Chain tightener, rear chamber
77868	1	Chain tightener, short chain
77884	1	Scraper plow rear
77992	1	Scraper back, plastic

Part Number	Qty.	Title
78943	1	Shim
78950	1	Bracket, chain lubrication
79365	1	Endpiece for shaft
79378	3	Spacer for end plug
80451	1	Rear chamber, weldment parts, MC850
80452	1	Rear chamber, weldment parts, MC850, hardox
80577	1	Weldment plate, rear chamber, right upper, MC850
80578	1	Weldment plate, rear chamber, right lower, MC850
80579	1	Weldment plate, rear chamber, left upper, MC850
80580	1	Weldment plate, rear chamber, left lower, MC850
81060	1	Spring

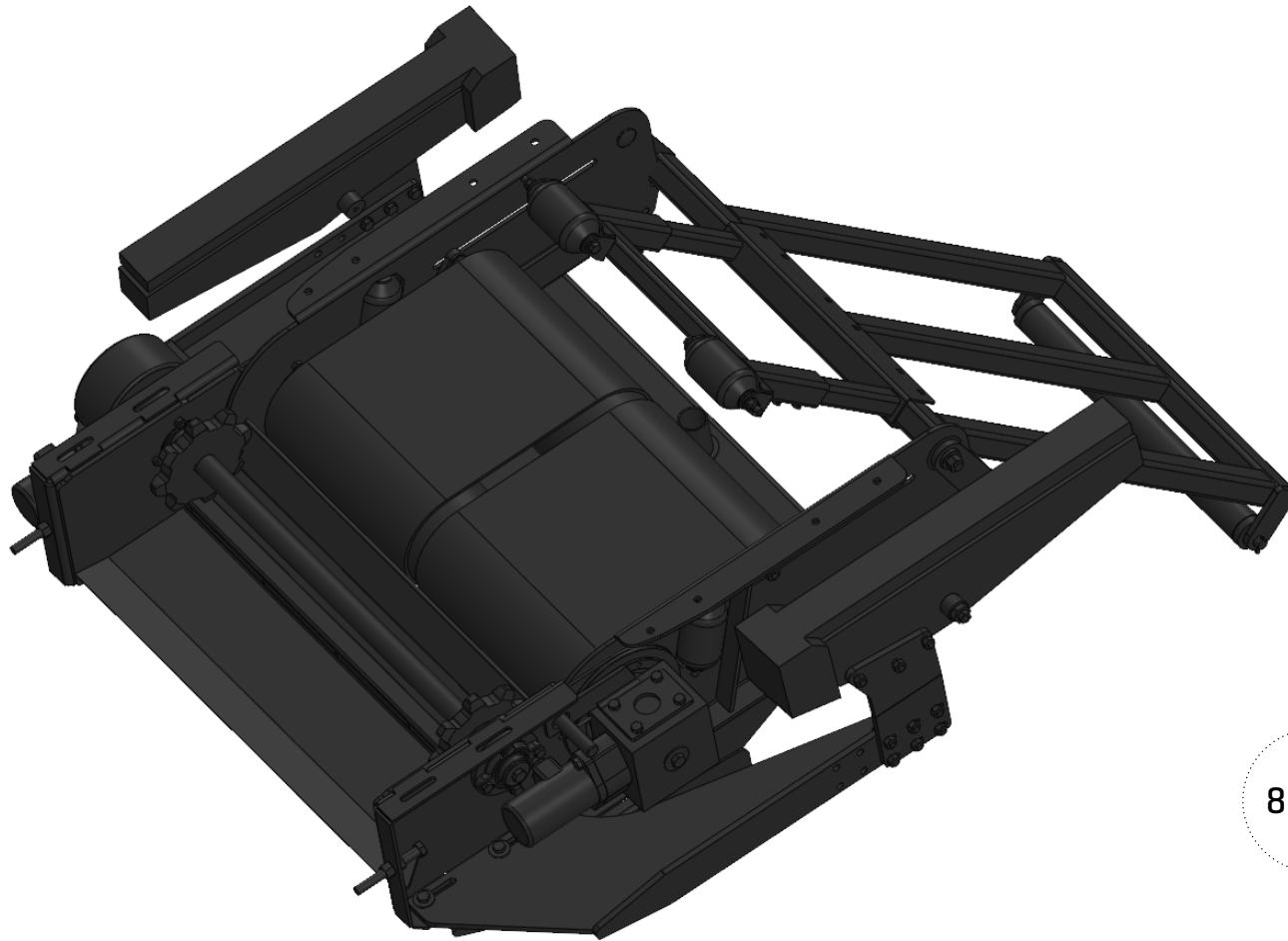

82056

Part number	Qty	Description
10348	1	Bolt M12x30
10350	10	Bolt M12x35
12067	23	Washer M12
13211	27	Lock nut M12
77027	1	Belt guide, wrapper
77875	1	Conveyor belt guide
77877	1	Drive shaft
82054	1	Side plate, left, 100 kg ball
82055	1	Side plate, right, 100 kg ball

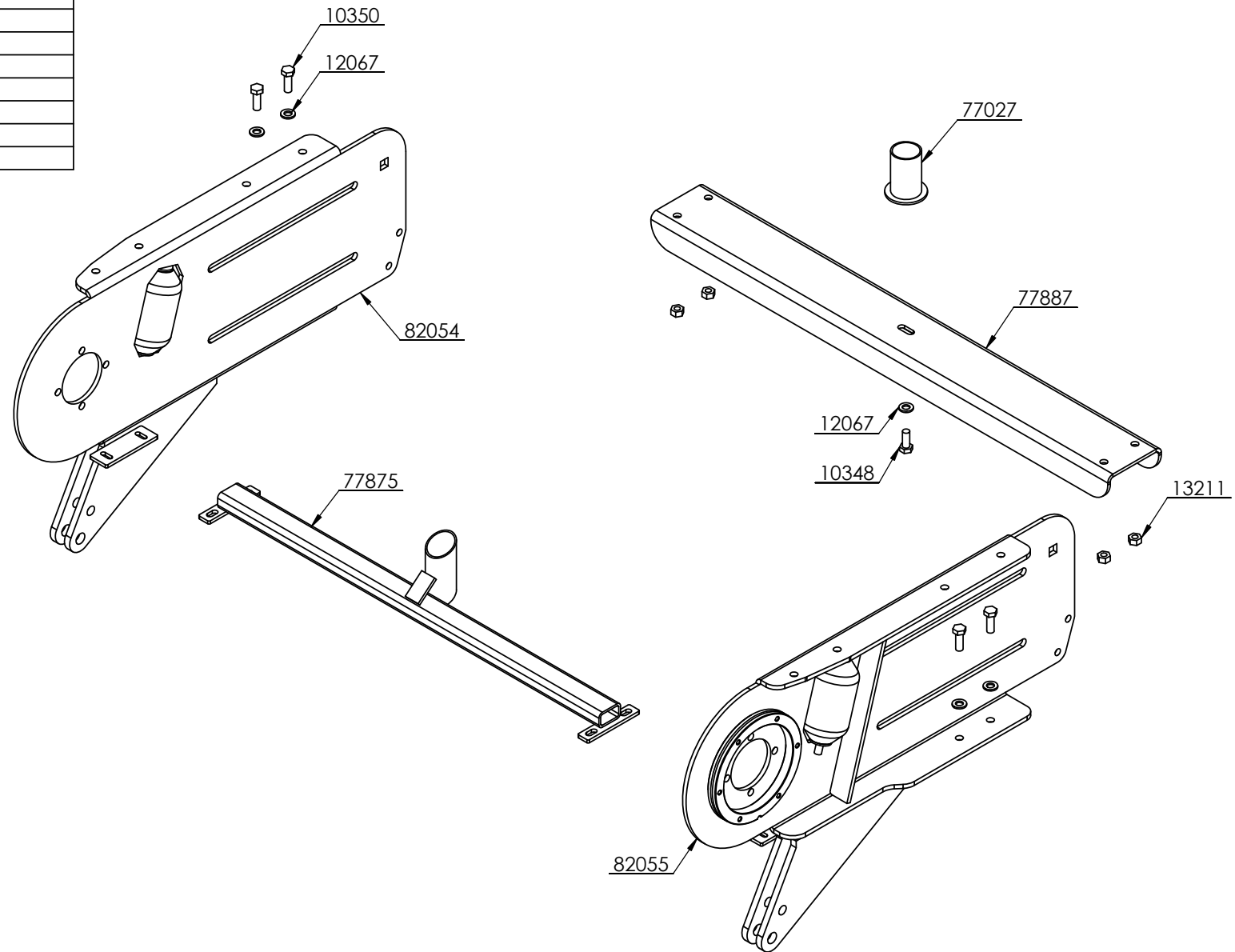

Part number	Qty	Description
10305	8	Bolt M10x45
12060	20	Washer M10
12072	4	Washer M14
13212	4	Lock nut M14
15301	4	Bolt M14x20
15318	4	Bolt M14x40
55016	4	Bearing UCFCX08
59025	2	Bearing UCFL208
77630	4	Washer $\varnothing 50/15 \times 3$
77873	1	Roller 2
77874	1	Roller 1
82318	2	Belt MC850 flex

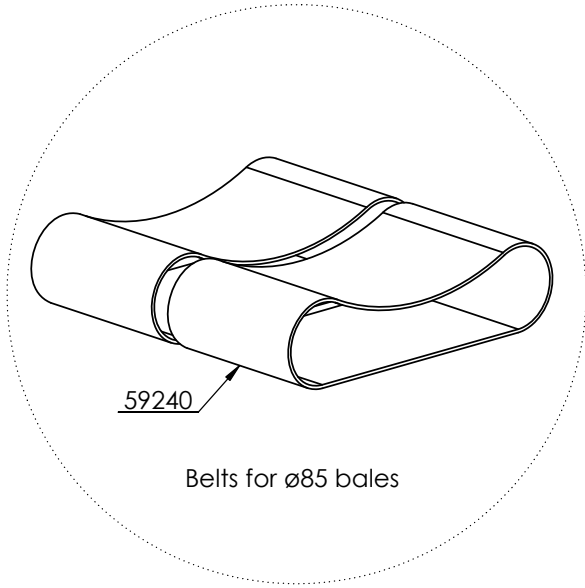
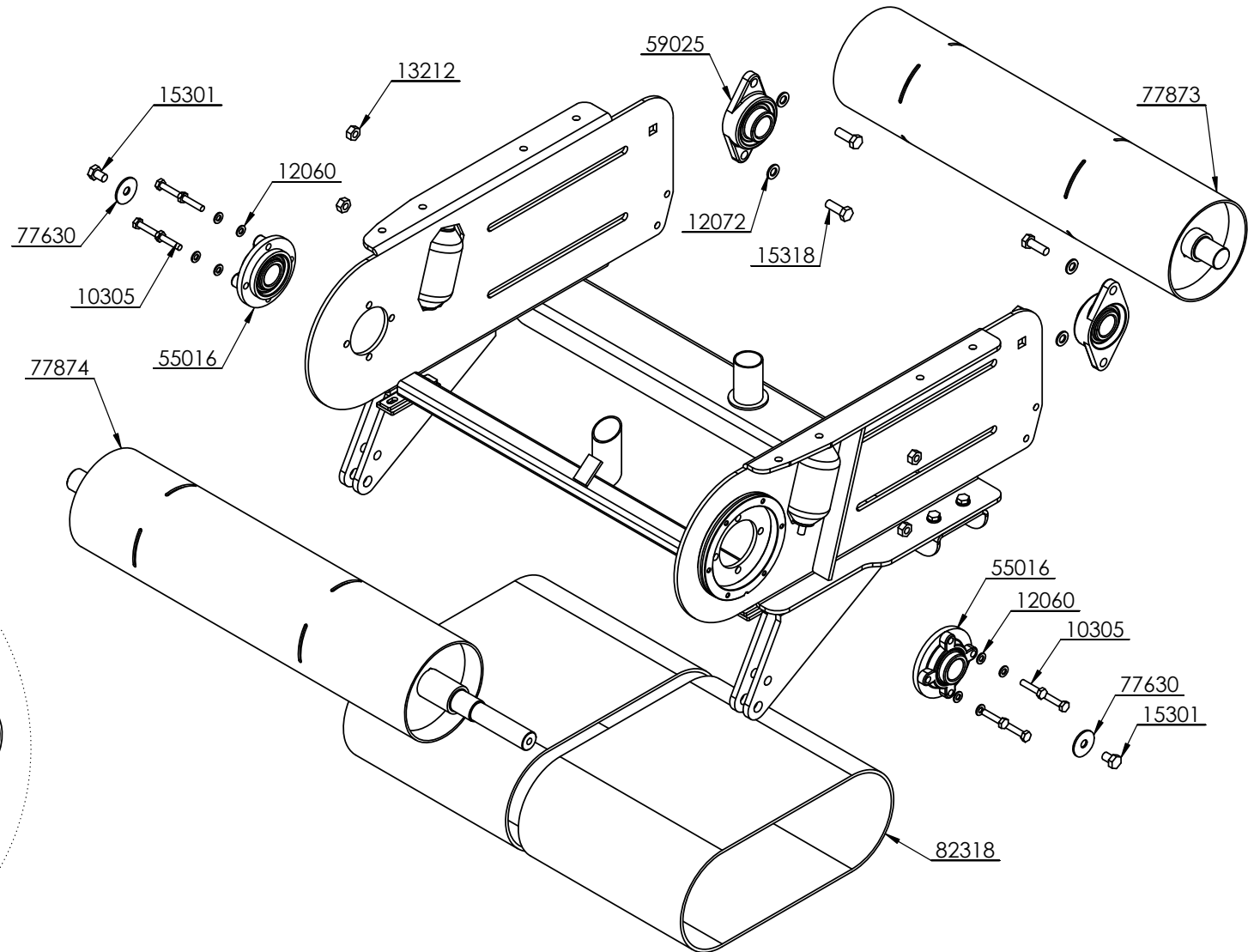

Part number	Qty	Description
11138	2	Locking head bolt M16x50
12078	2	Washer M16
13213	6	Lock nut M16
14121	2	Splint $\varnothing 8 \times 30$
77413	2	Bale tray, roller bushing
77890	1	Roller tray roller, pipe
77891	1	Shaft, roller, bale tray
78850	2	Shim
78851	2	Spacer
78852	2	Lock washer
79703	1	Roller tray frame
79885	1	Bale supporter 100 kg bale
82054	1	Side plate, left, 100 kg ball
82055	1	Side plate, right, 100 kg ball

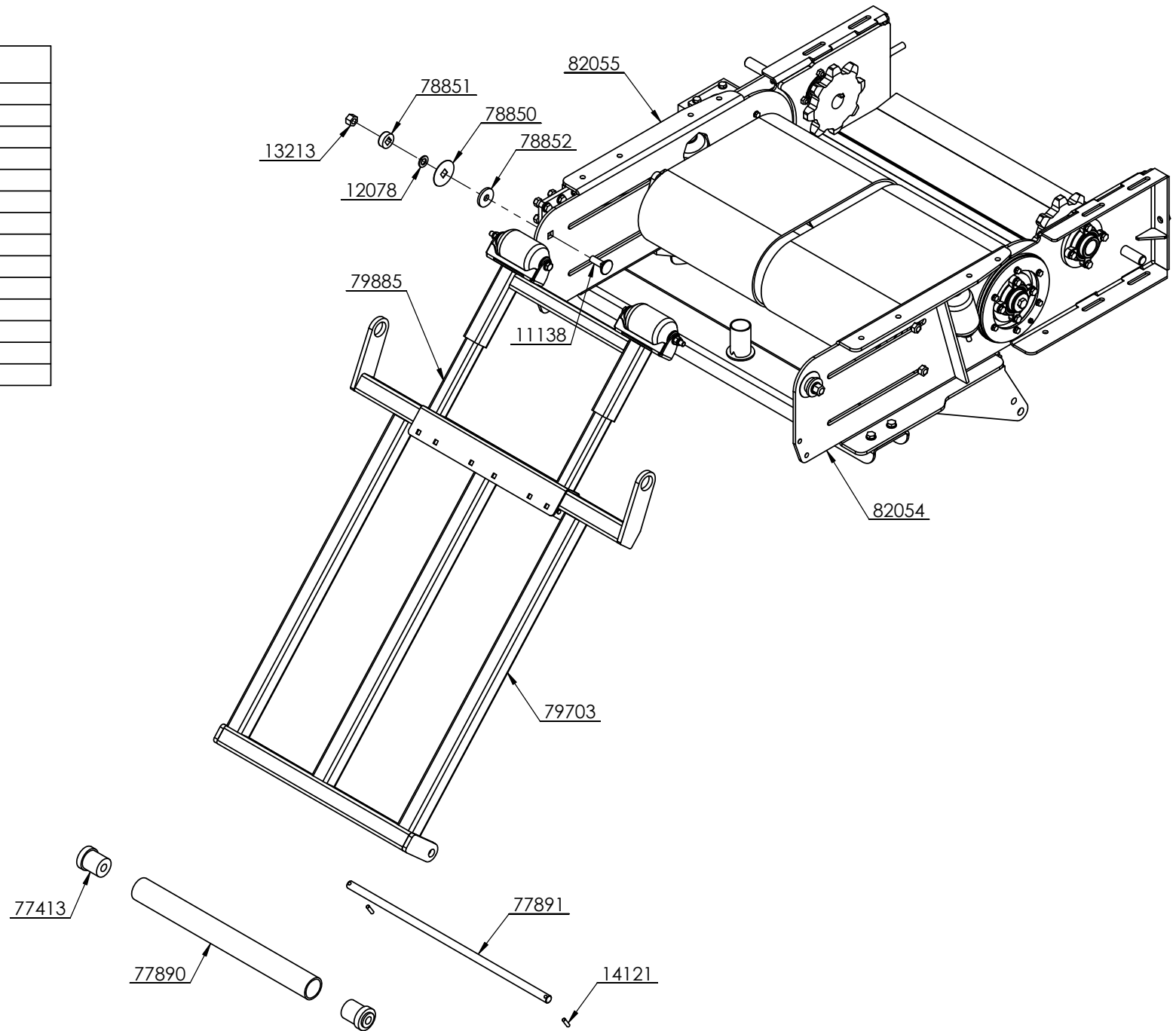

Part number	Qty	Description
10244	12	Bolt M8x20
12047	12	Washer M8
12060	20	Washer M10
12247	12	Spring washer M8
14001	2	Grease nipple 1/8" R
15301	4	Bolt M14x20
50324	2	Key 12x8x60
52507	2	Key 12x8x50
55016	4	Bearing UCFCX08
59081	2	Sprocket
77630	4	Washer $\phi 50/15 \times 3$
77869	1	Hinge plate left
77870	1	Hinge plate right
77877	1	Drive shaft
77885	1	Tray 1 to frame
77886	1	Tray 2 to frame

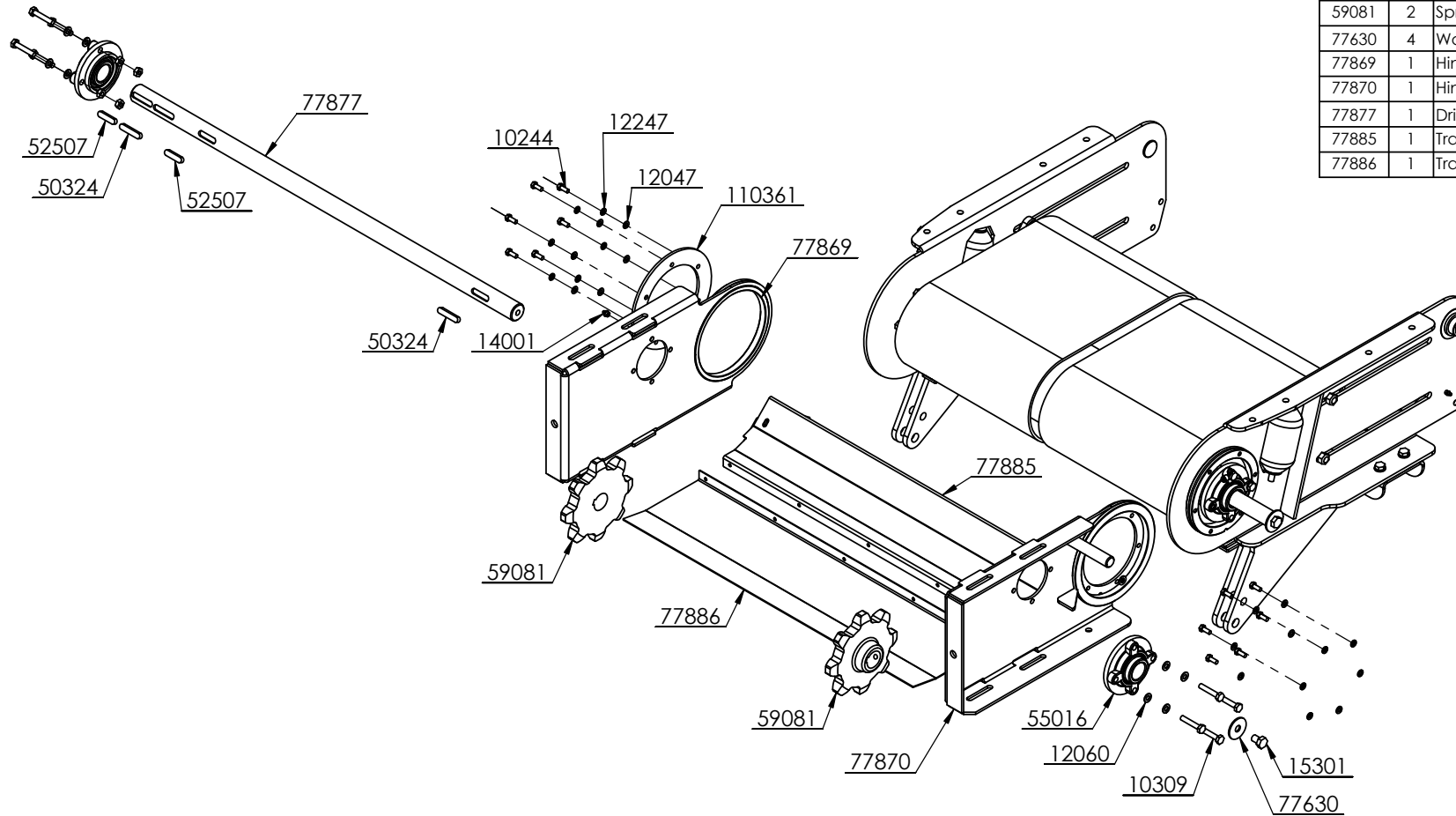

Part number	Qty	Description
10346	2	Bolt M12x25
10350	10	Bolt M12x35
10352	12	Bolt M12x40
10356	5	Bolt M12x50
11518	4	Countersunk bolt M12x30
12067	23	Washer M12
12178	5	Washer $\varnothing 37/13 \times 3$
13211	27	Lock nut M12
13213	6	Lock nut M16
15202	2	Bolt M16x130, threaded to head
15301	4	Bolt M14x20
77630	4	Washer $\varnothing 50/15 \times 3$
77712	1	Bracket, gear RT 160, reinforced
77932	2	Bracket, film cutter
77999	2	Bracket, film cutter
59039	1	Gear RT 160
59853	1	Motor BG80 NC25
15313	2	Bolt M12x40

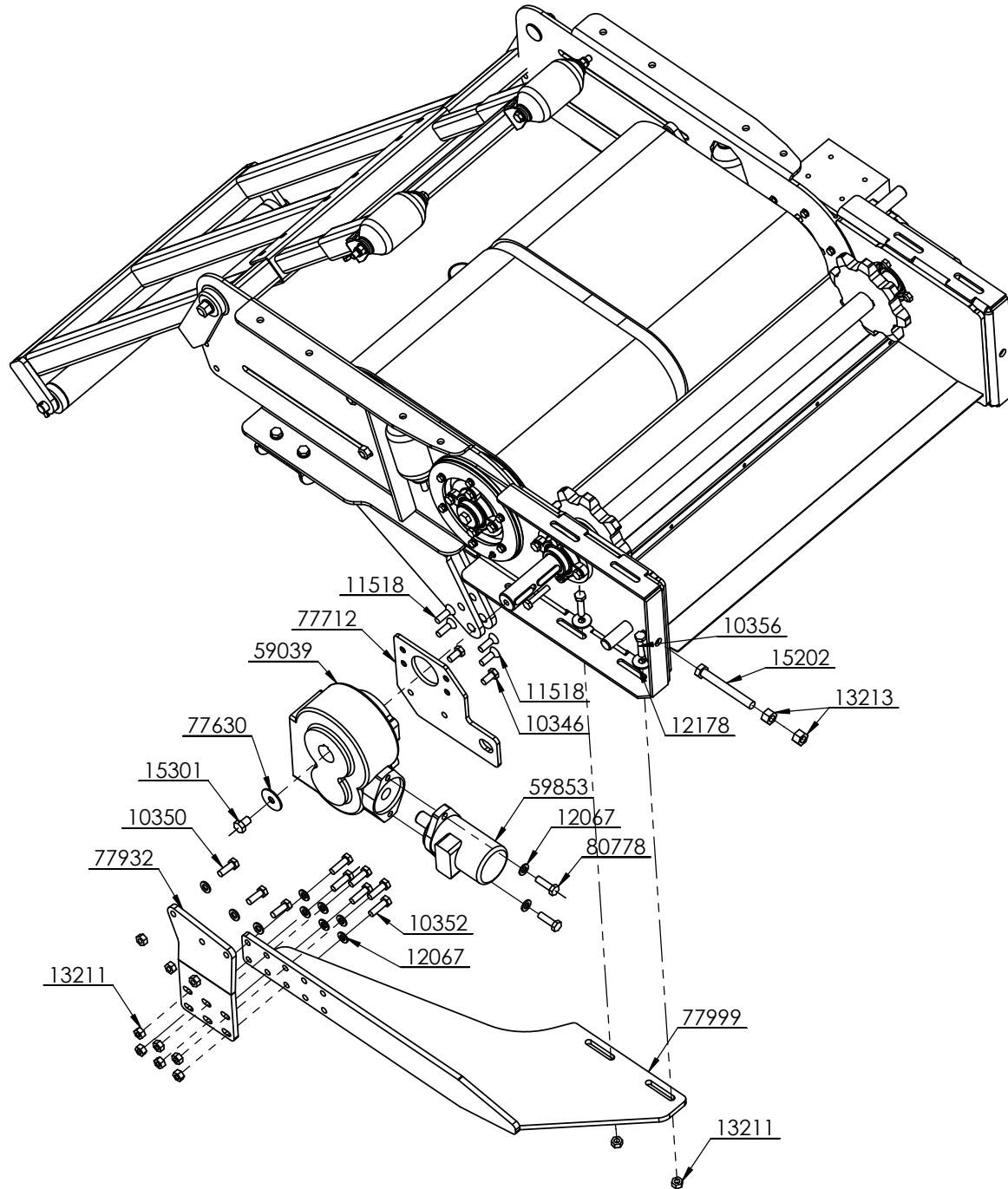

Part number	Qty	Description
10299	4	Bolt M10x30
10350	10	Bolt M12x35
10352	12	Bolt M12x40
10356	5	Bolt M12x50
12060	20	Washer M10
12067	23	Washer M12
12178	5	Washer ø37/13x3
13211	27	Lock nut M12
13213	6	Lock nut M16
15202	2	Bolt M16x130, threaded to head
15301	4	Bolt M14x20
77136	1	Bracket, gear
77630	4	Washer ø50/15x3
77932	2	Bracket, film cutter
77966	1	Sensor bracket, wrapping table
77999	2	Bracket, film cutter
79704	1	Grease nipple extender
59038	1	Gear RT 90
59053	1	Motor BR200 NC25

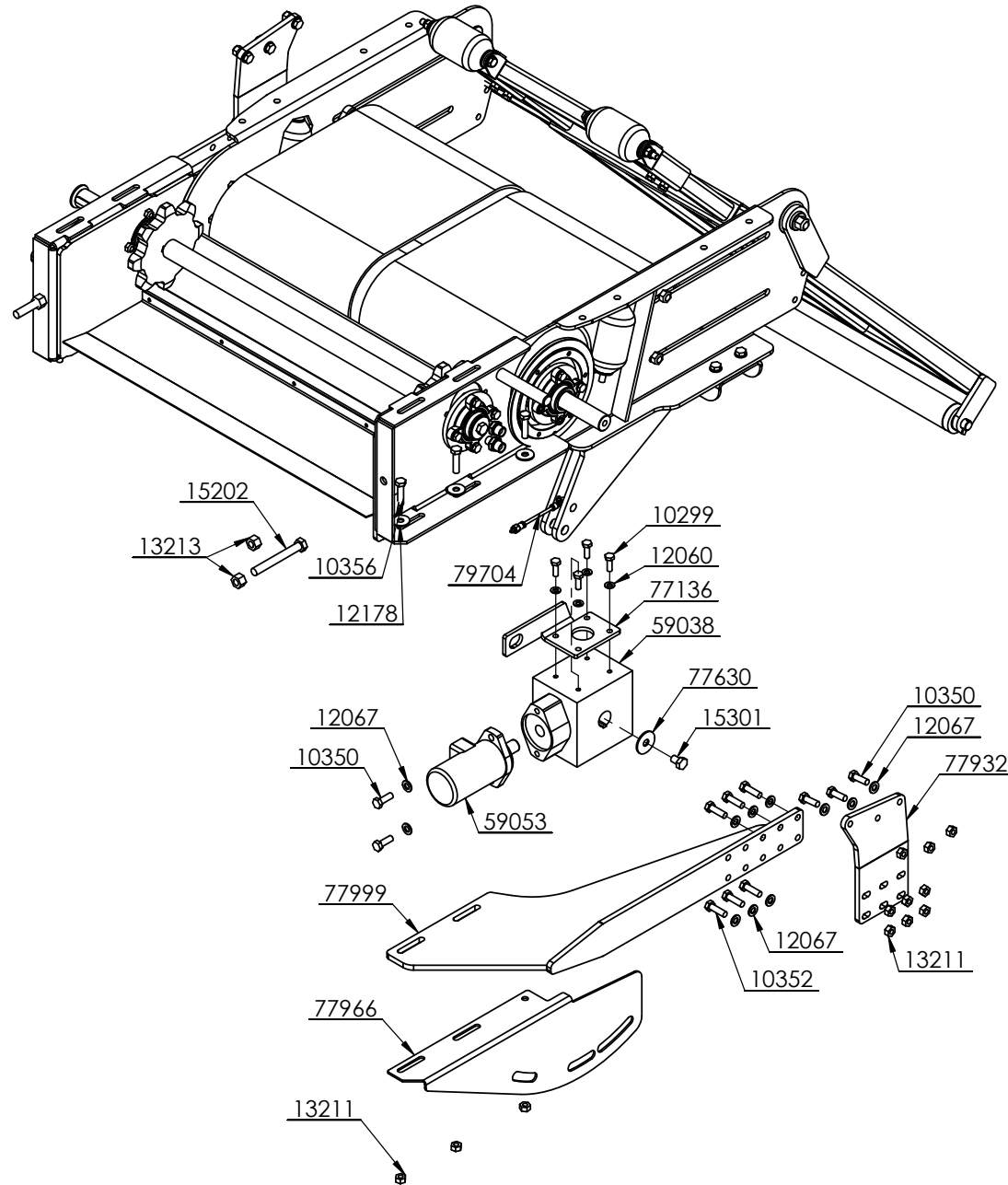

Part number	Qty	Description
10240	3	Bolt M8x16
10244	1	Bolt M8x20
10582	1	Bolt M20x90
12047	2	Washer M8
12088	1	Washer M20
13011	1	Nut M12
14002	1	Grease nipple M8x1
14138	1	Splint 8x32 DIN 1481
58577	1	Spring
58870	1	Cylinder 50x35x700
67205	1	Gasket for cylinder, film stretcher
81283	1	Presser
81284	2	Presser pipe
81285	1	Pipe holder
81287	1	Rubben plate
81288	1	Holder plate
81289	1	Holder plate hinge
81290	1	Knife
81291	1	Knife plate
81292	1	Frame
81293	2	Limiter
81294	1	Washer
81295	1	Cylinder pin
81296	1	Hinge bolt

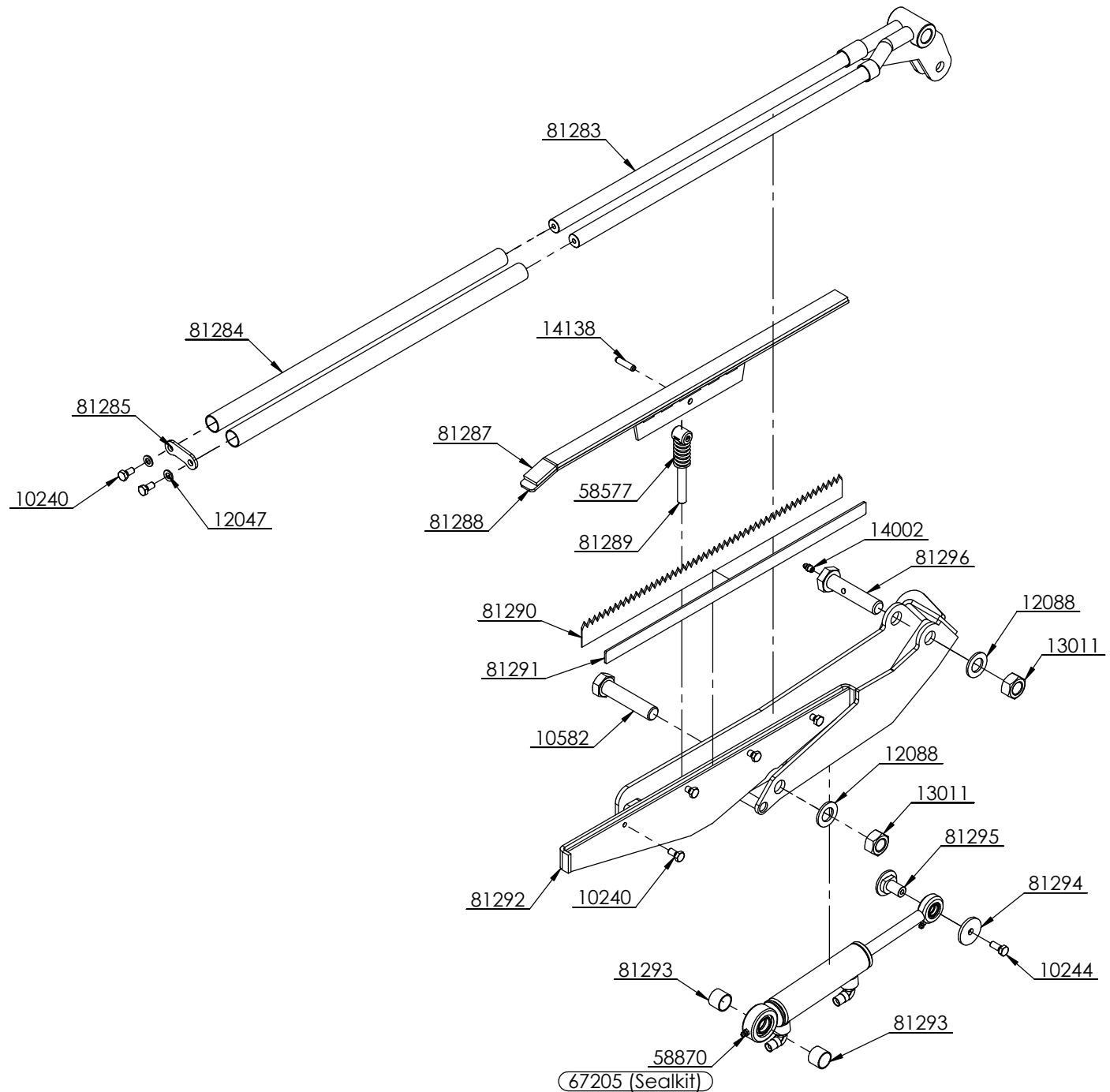

77980
Film cutter
complete



Compactor
Wrapping table

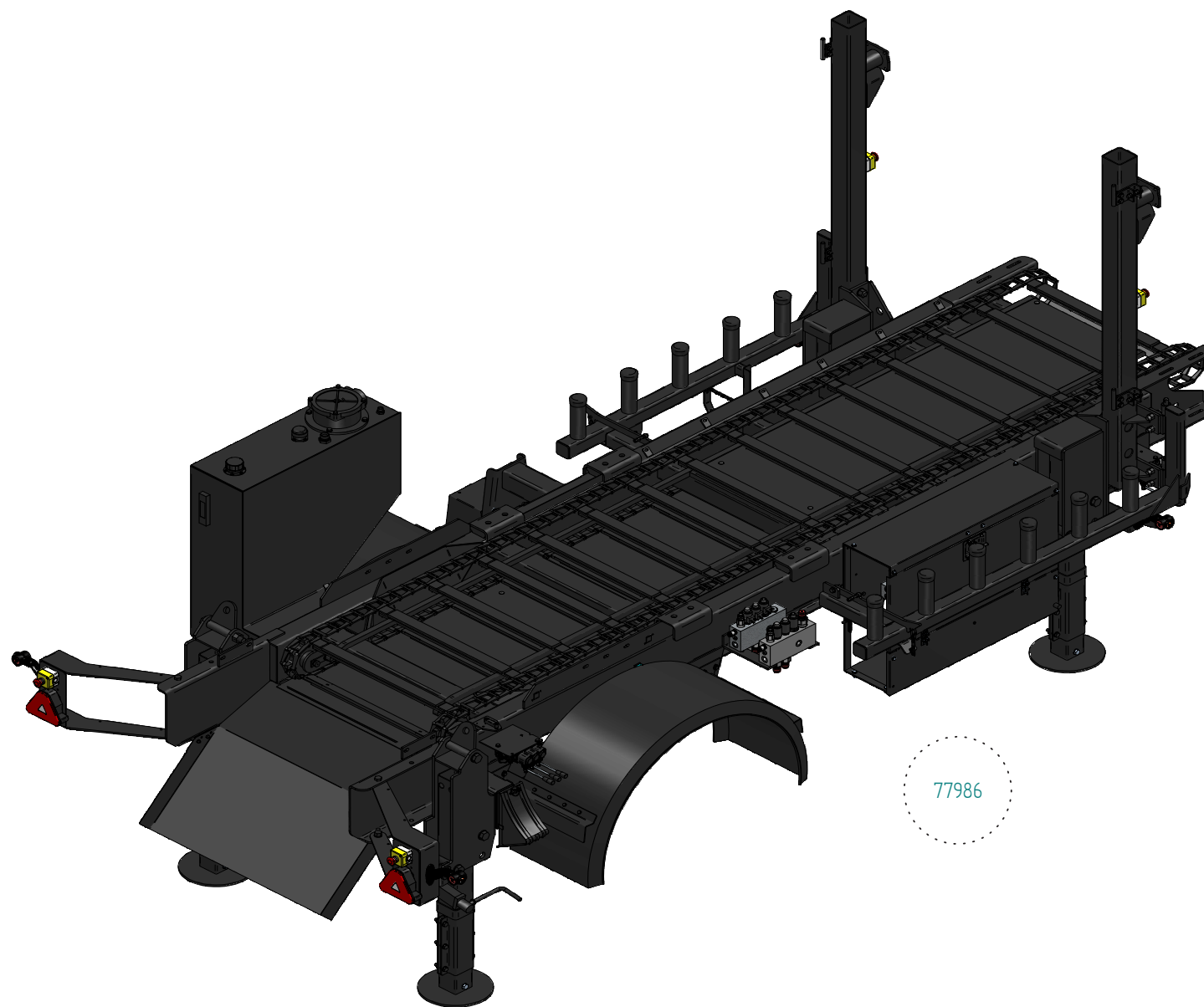

77986

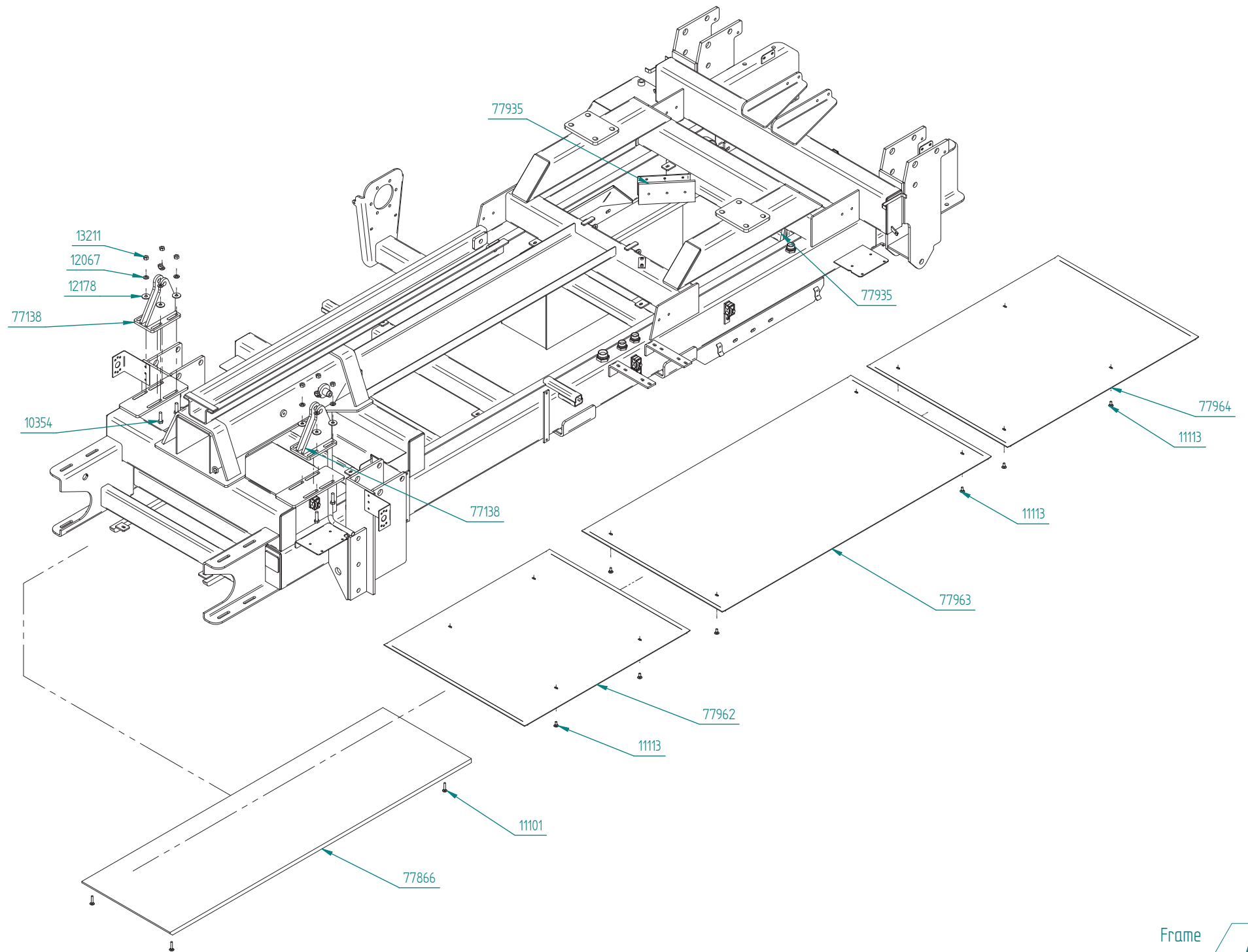

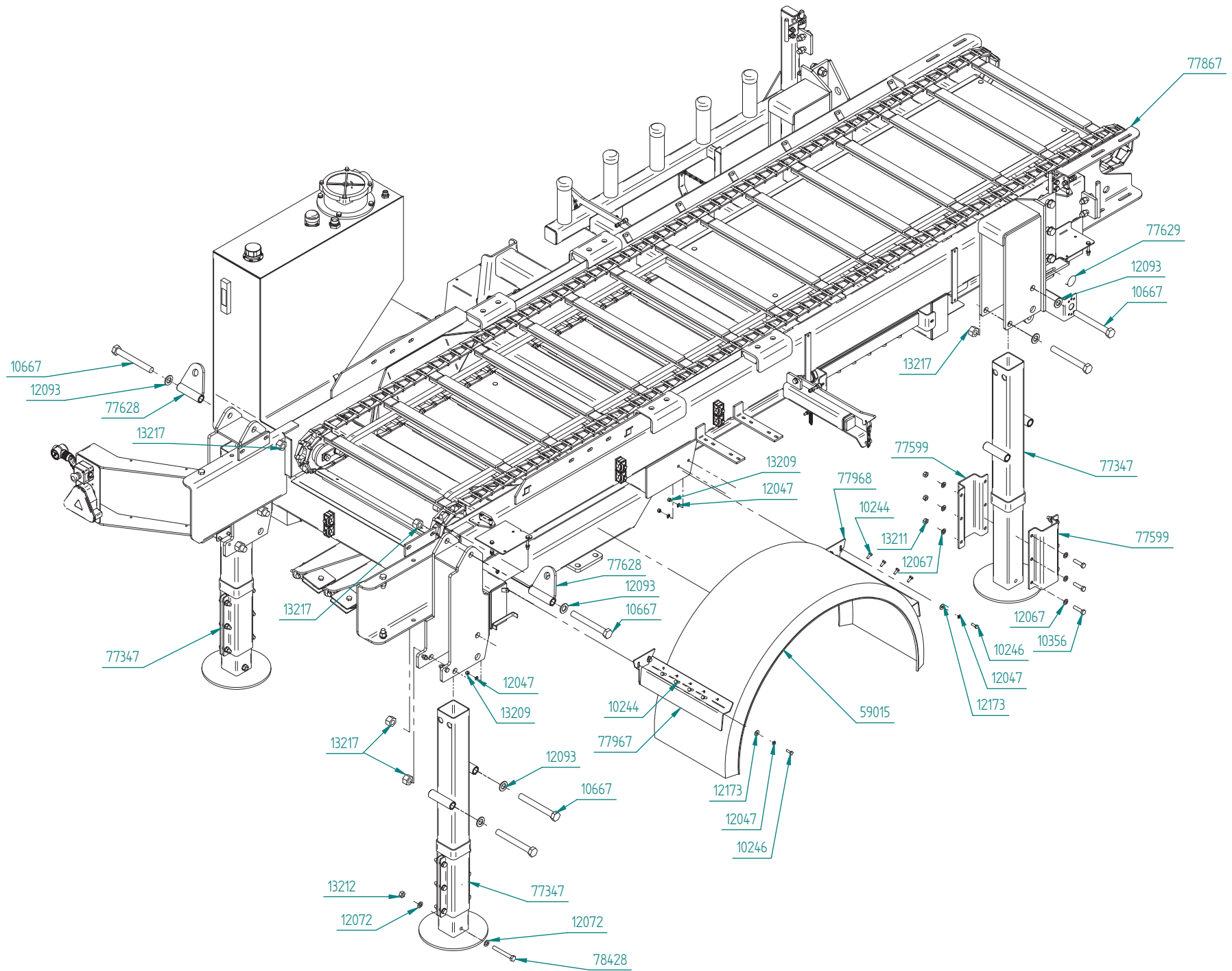

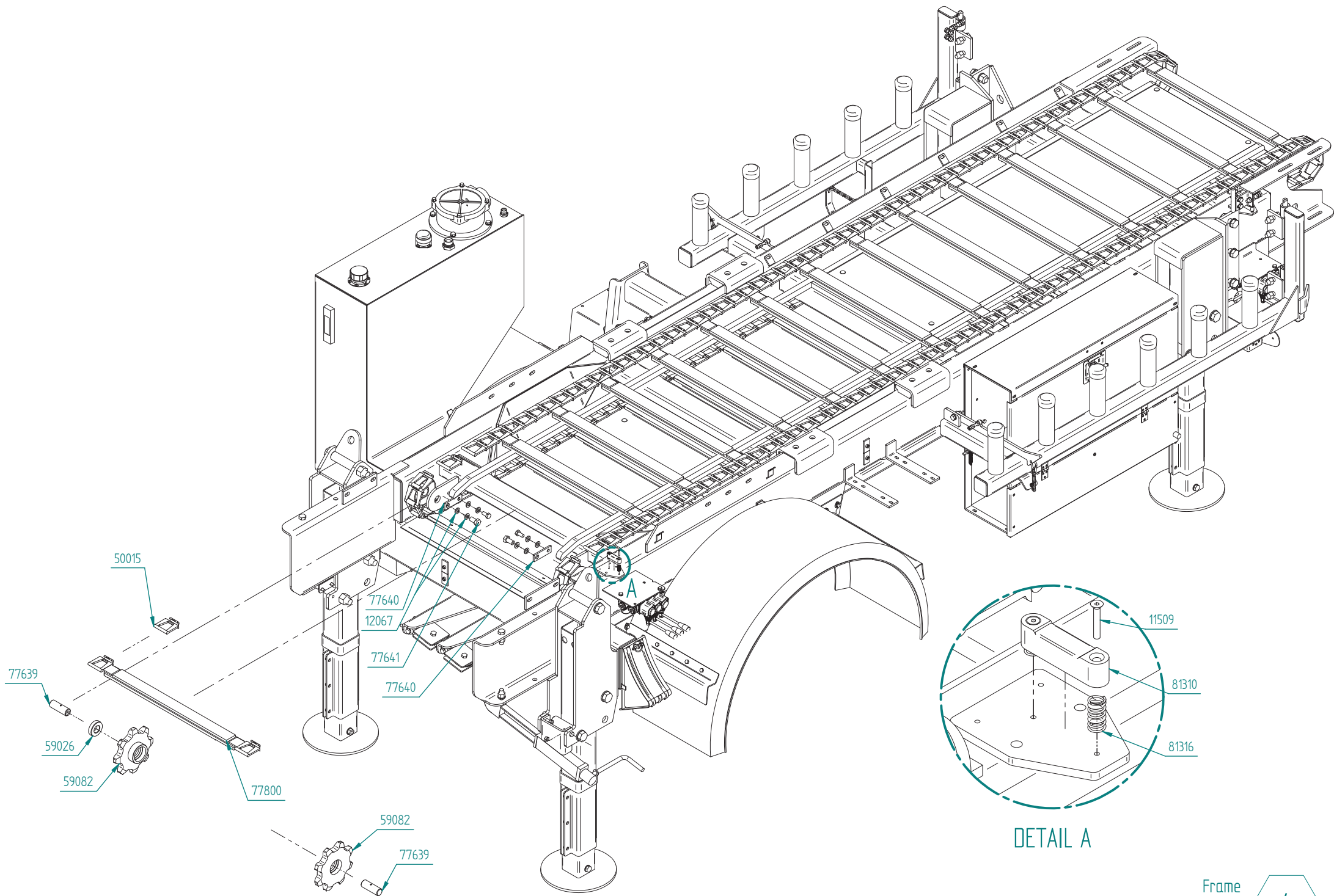

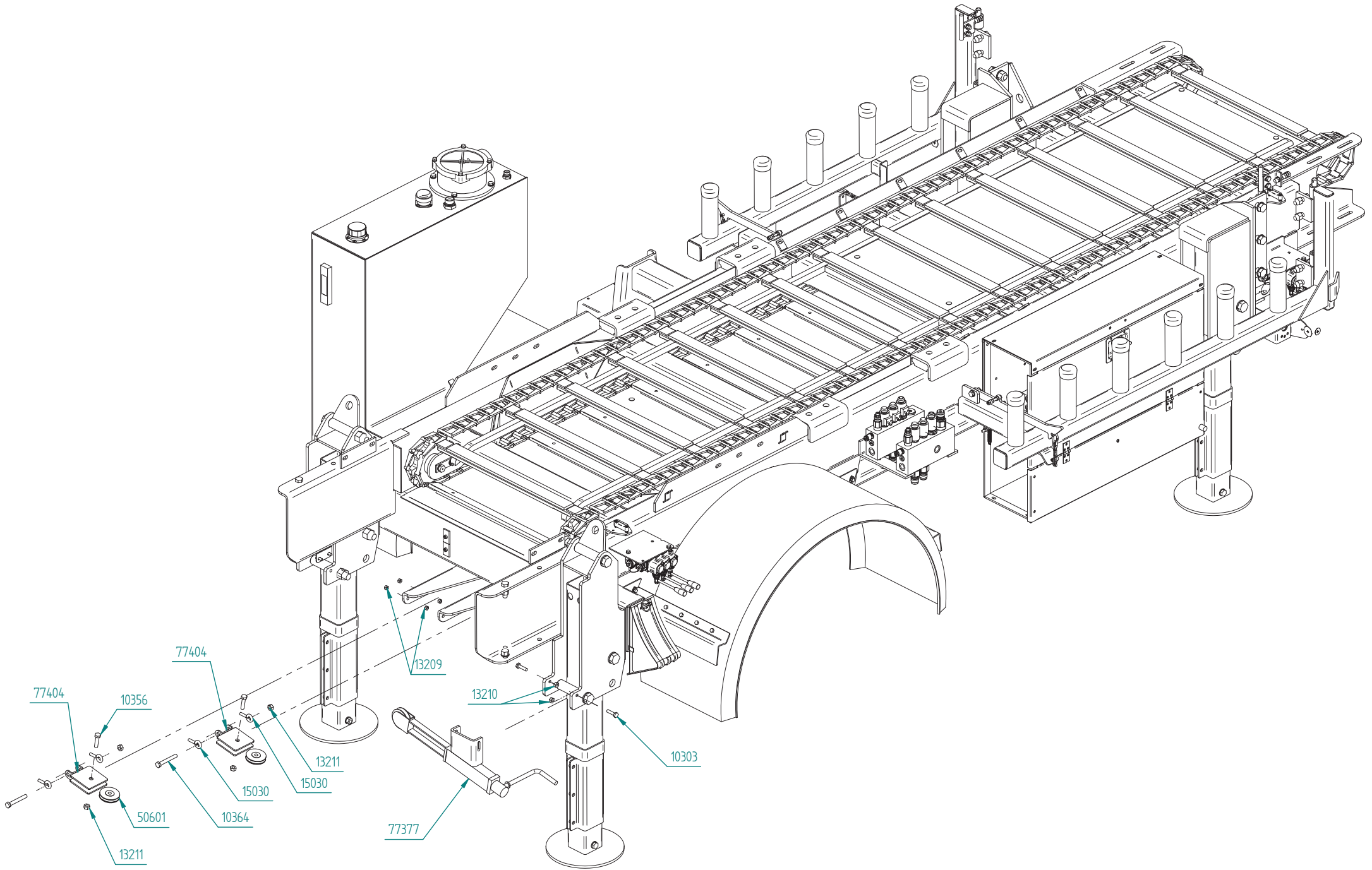

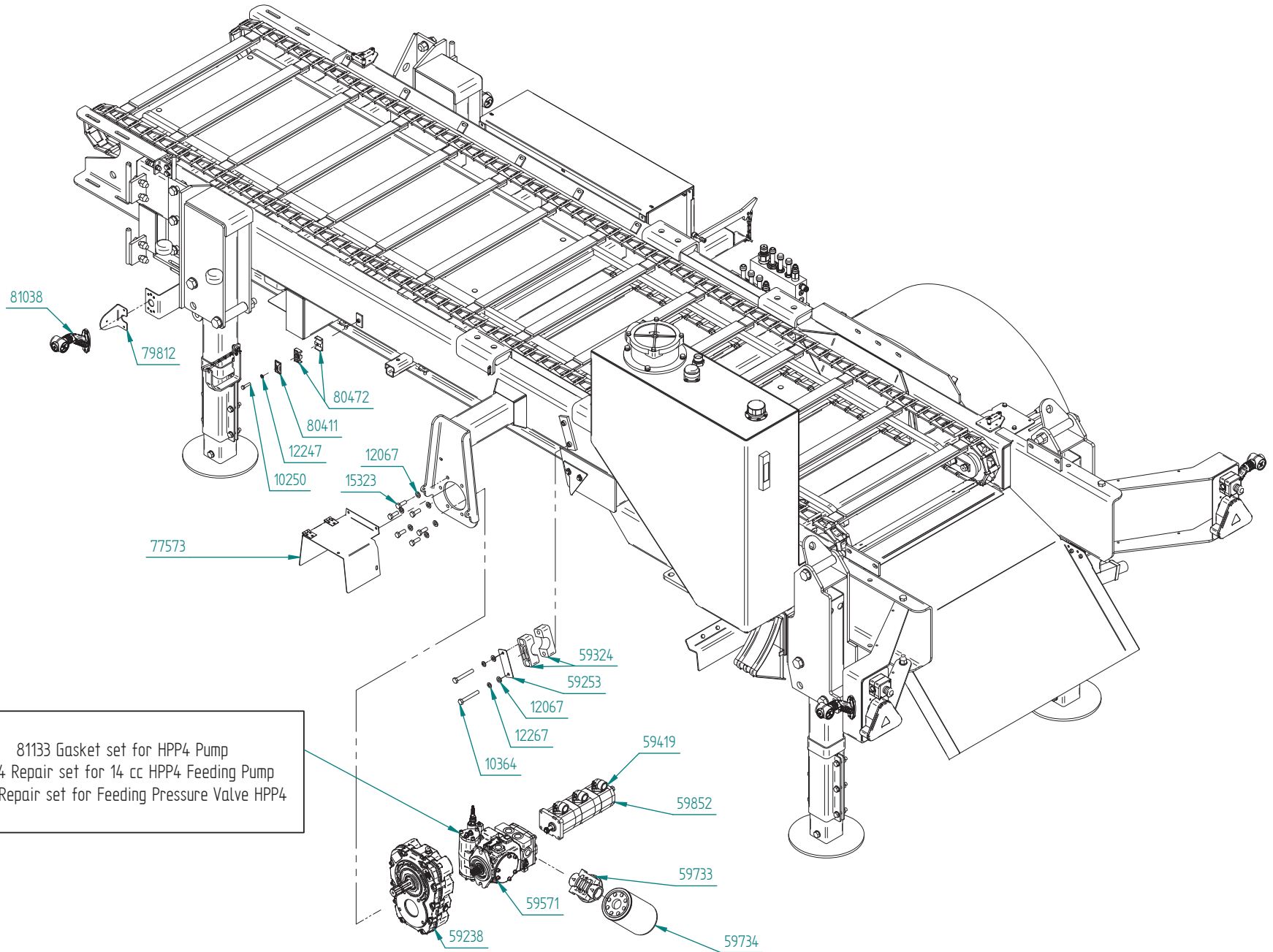

81133 Gasket set for HPP4 Pump
 81134 Repair set for 14 cc HPP4 Feeding Pump
 81135 Repair set for Feeding Pressure Valve HPP4

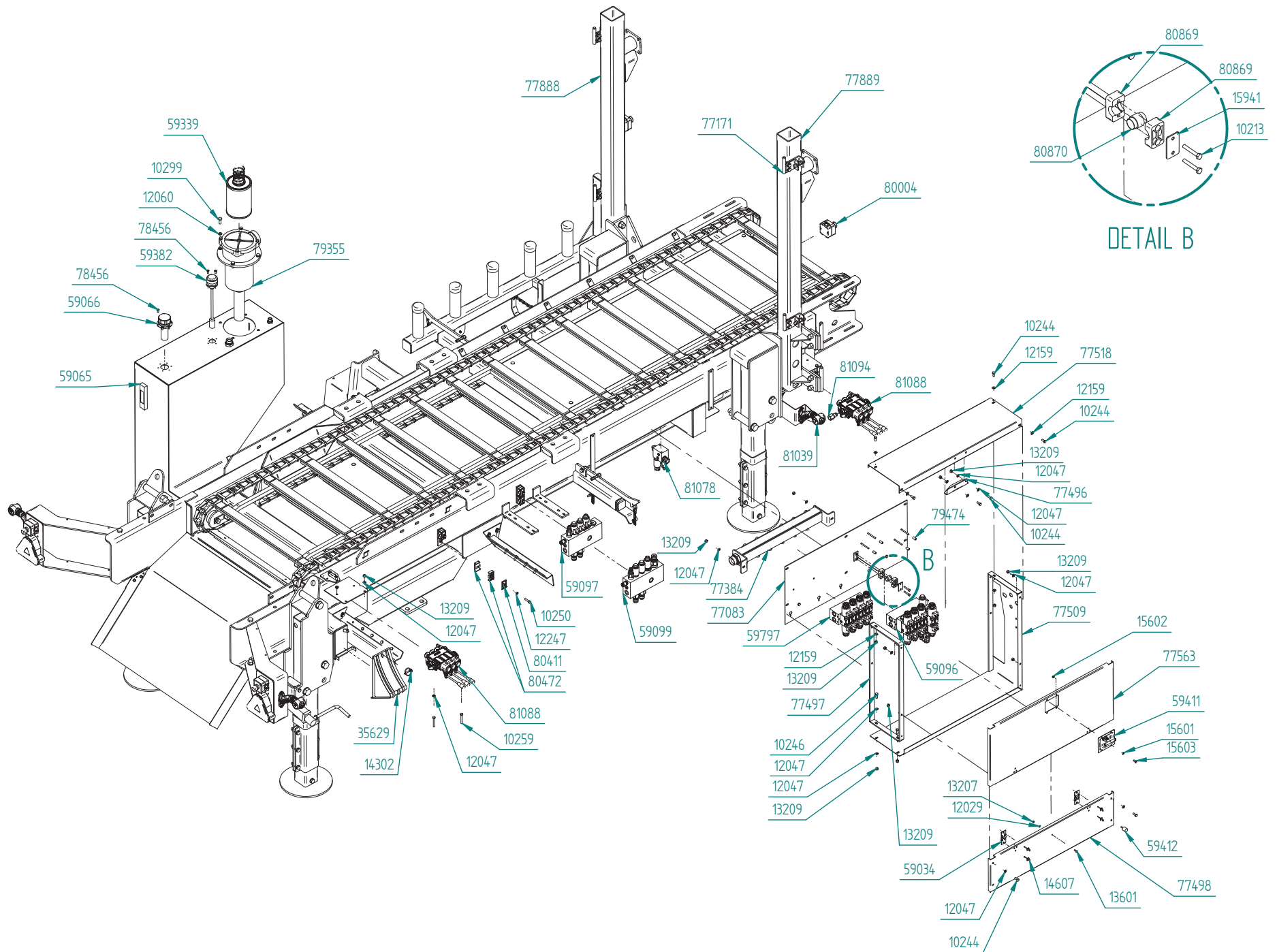

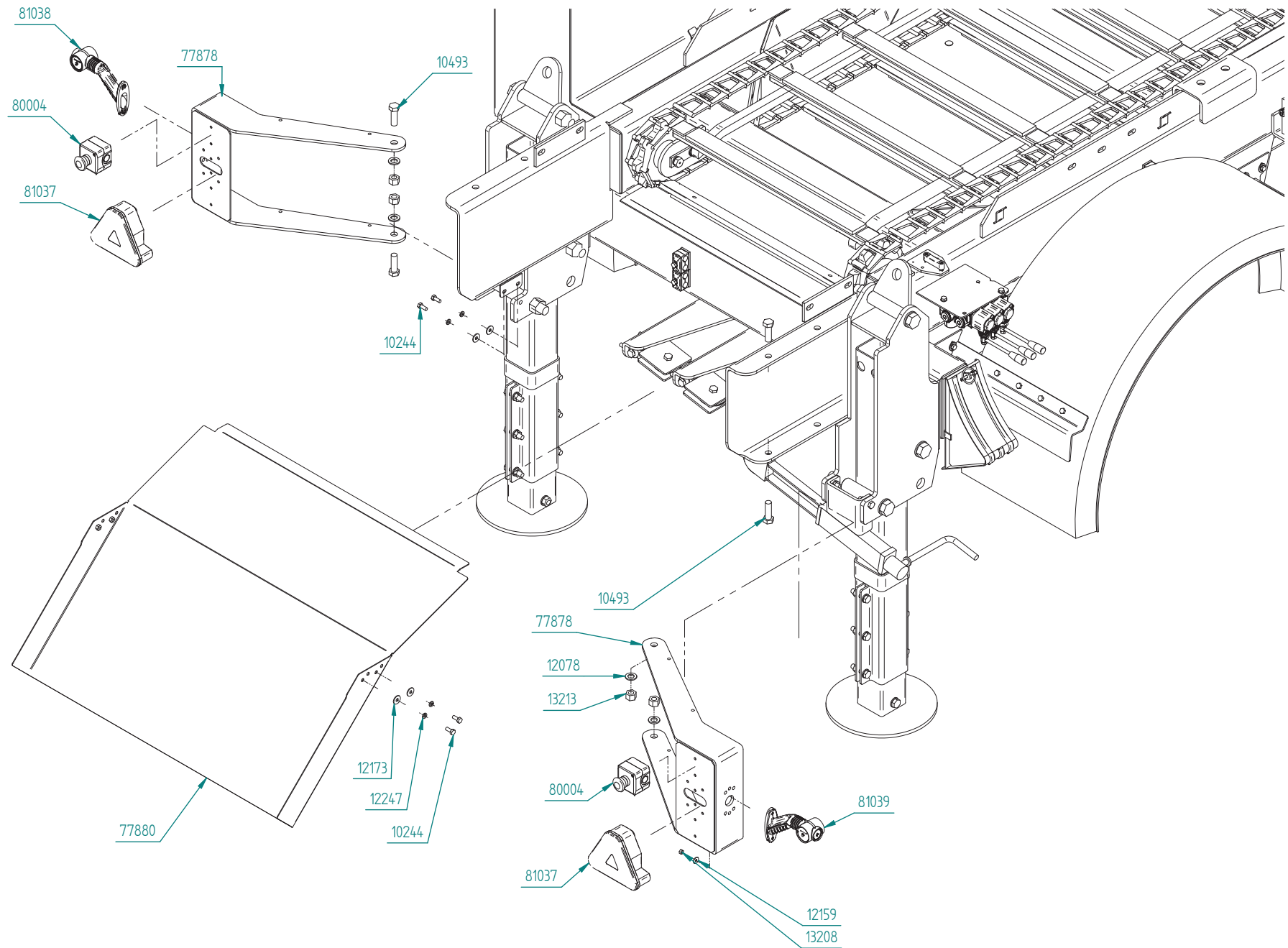

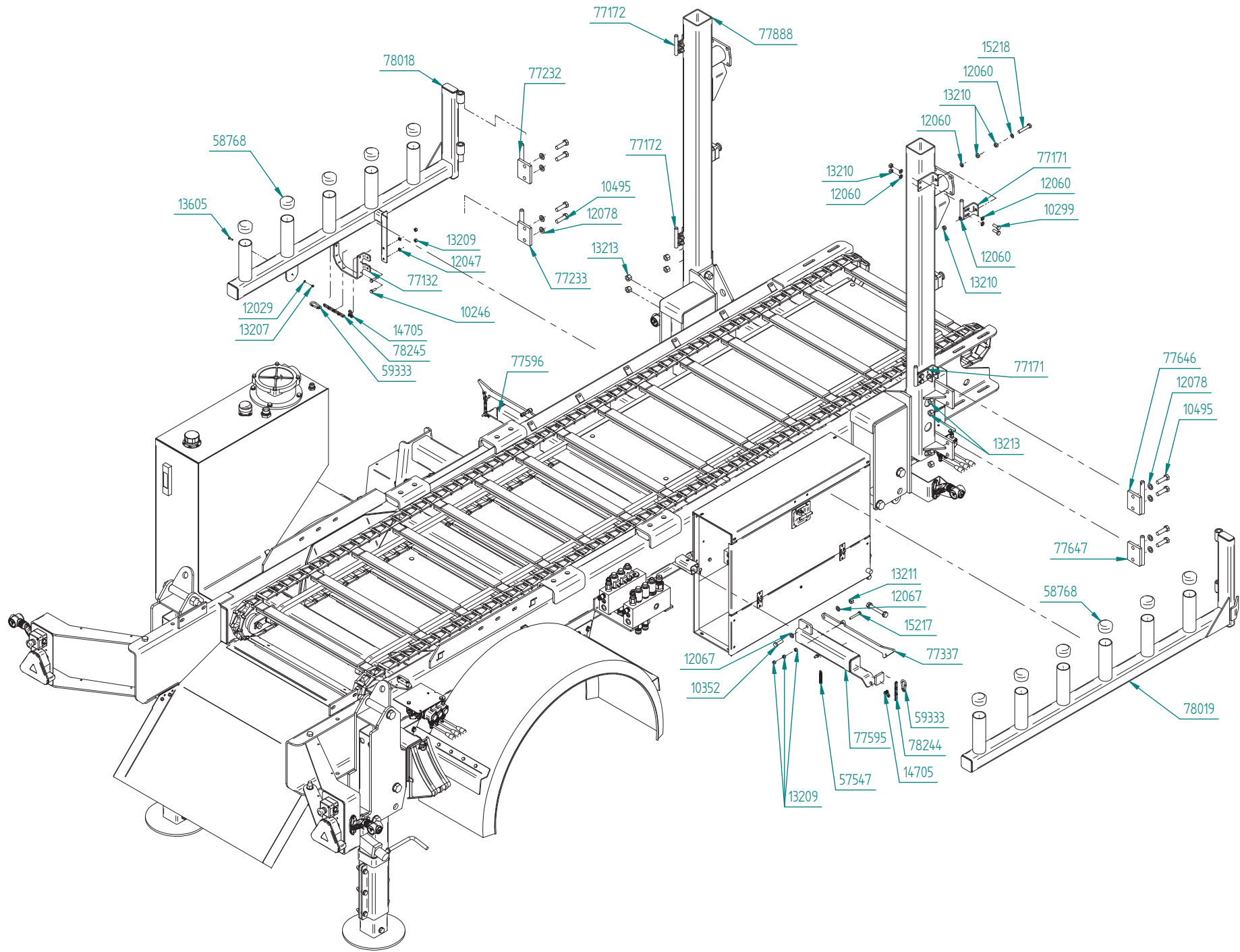

Part Number	Qty.	Title
10213	2	Bolt M6x40
10244	28	Bolt M8x20
10246	12	Bolt M8x25
10250	11	Bolt M8x35
10259	4	Bolt M8x60
10299	12	Bolt M10x30
10303	2	Bolt M10x40
10346	2	Bolt M12x25
10352	2	Bolt M12x40
10354	8	Bolt M12x45
10356	28	Bolt M12x50
10364	6	Bolt M12x90
10493	4	Bolt M16x50
10495	8	Bolt M16x55
10577	6	Bolt M20x60
10667	10	Bolt M24x200
11101	4	Lock head bolt M8x40
11113	12	Locking head bolt M8x20
11509	6	Countersunk bolt M4x25
12029	18	Washer M5
12036	10	Washer M6
12047	57	Washer M8
12060	40	Washer M10
12067	76	Washer M12
12072	8	Washer M14

Part Number	Qty.	Title
12078	12	Washer M16
12088	12	Washer M20
12093	10	Washer M24
12159	38	Washer \varnothing 18/6,4
12173	12	Washer \varnothing 24/8,4x2
12178	8	Washer \varnothing 37/13x3
12247	5	Spring washer M8
12267	2	Spring washer M12
13207	10	Lock nut M5
13208	10	Lock nut M6
13209	52	Lock nut M8
13210	22	Lock nut M10
13211	42	Lock nut M12
13212	4	Lock nut M14
13213	12	Lock nut M16
13215	6	Lock nut M20
13217	10	Lock nut M24
13601	9	Pan bolt M5x16
13605	1	Pan bolt M5x20
14302	2	Ear pin M6
14607	12	Pop Rivet \varnothing 4,8x11
14705	3	Shackle 3/6
15030	4	Eye bolt M10x30
15217	2	Bolt M8x60, threaded to head
15218	4	Bolt M12x65, threaded to head

Part Number	Qty.	Title
15323	6	Bolt M12x35
15601	4	Washer M6, rust free
15602	4	Lock nut M6, rust free
15603	4	Bolt M6x16, rust free
15941	1	Top plate for plastic tube clamp
35629	2	Parking block
50015	188	Chain link Kohlswa Ewart 78
50601	4	Wire-pulley \varnothing 75x16
57547	2	Spring
58768	11	Plastic cap \varnothing 60
59015	2	Cover, plastic
59026	2	Bearing 6206 2RS
59034	2	Hinge
59065	1	Level glass
59066	1	Filler cap
59082	2	Sprocket, impeller
59096	1	Block 33.2
59097	1	Block 33.3
59099	1	Block 33.4
59238	1	Gear B600
59253	1	Top plate for plastic clamp
59266	3	Port flange 90Gr \varnothing 30x1/2"
59324	4	Plastic clamps 50 mm
59333	3	Carbine hook 6 mm
59339	1	Filter element

Part Number	Qty.	Title
59382	1	Level/temperature watch
59411	1	Door lock
59412	1	Rubber buffer
59419	3	Port flange $\varnothing 40 \times 3/4''$
59571	1	Pump
59654	2	Rubber buffer 10x50x50
59733	1	Filter head
59734	1	Suction filter
59797	1	Blokk 33.1
59852	1	Triple pump
77083	1	Fastening plate, hydraulic valves
77132	1	Suspension, PTO driveshaft
77138	2	Cylinder bracket
77171	2	Hinge, right
77172	2	Hinge, left
77232	1	Hinge, left plastic storage, upper
77233	1	Hinge, left plastic storage, lower
77337	2	Plastic storage, lock
77347	4	Hydraulic jack
77377	1	Handbrake with fastener
77384	1	Manifold, hydraulic return
77404	4	Pulley holder
77496	1	Lock counterpart, hydraulic cabinet
77497	1	Rear bow, hydraulic cabinet
77498	1	Lower cover, hydraulic cabinet

Part Number	Qty.	Title
77509	1	Hydraulic cabinet
77518	1	Upper cover, hydraulic cabinet
77563	1	Front cover, hydraulic cabinet
77573	1	Cover, PTO
77595	1	Stopper, plastic storage, right
77596	1	Stopper, plastic storage, left
77599	8	Clamp
77628	2	Lifting lug
77629	1	Ring for wire $\varnothing 50 \times 8$
77639	2	Bolt, chain sprocket
77640	2	Locking, chain sprocket bolt
77641	2	Bolt, locking, sprocket
77646	1	Hinge, right plastic storage, upper
77647	1	Hinge, right plastic storage, lower
77800	31	Carrier
77866	1	Visaform plate
77867	1	Frame, MC
77878	2	Light bracket
77880	1	Transition elevator/frame
77888	1	Beam, left side
77889	1	Beam, right side
77935	2	Rubber, scraper, belt under
77962	1	Trough, rust free, front
77963	1	Bodenplatte mitte
77964	1	Bodenplatte hinten

Part Number	Qty.	Title
77967	2	Cover fastener, left
77968	2	Cover fastener, right
78018	1	Plastic storage, left
78019	1	Plastic storage, right
78244	2	Chain 4 mm long chained
78245	1	Chain 4 mm long chained
78428	4	Bolt M14x110
78456	10	Pan bolt M6x16
79355	1	Filter, complete with pipe
79474	4	Pipe $\varnothing 10 \times 1,5$ L=20
79812	2	Bracket plate, front reflector
80004	4	Emergency switch
80411	11	Topp-Plate 14-18mm dobbel Stauff
80472	11	Pipe clamp double 18 mm
80869	2	Tube clamp, plastic
80870	1	Rubber casting 20mm
81037	2	Agripoint Full LED 5 pin connector
81038	2	Marker light, left LED
81039	2	Marker light, right LED
81078	1	Valve block assembly, with 12V coil
81088	2	Hydraulic valve, P40 A1x3 SKZ
81094	1	Pressure continuation plug
81310	3	Hultafors Libelle leveller NV 702
81316	6	Compression spring, Lesjefors 1406, Fn=54

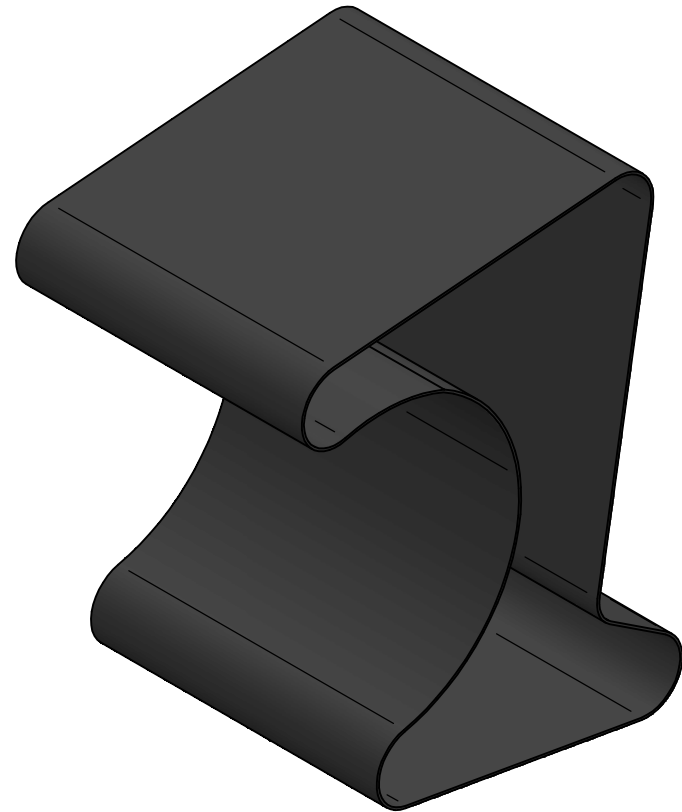
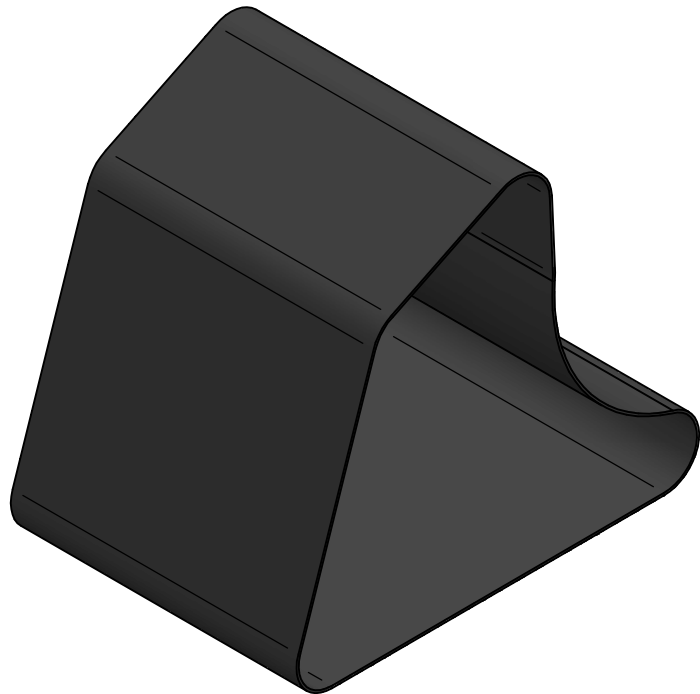

Part Number	Qty.	Title
59529	1	Belt, front chamber, endless, EP 250/2 3+1
59530	1	Belt, rear chamber, endless, EP 250/2 3+1
59599	1	Belt, front chamber, w/lock, EP 250/2 3+1
59600	1	Belt, rear chamber, w/lock, EP 250/2 3+1
59786	1	Alligator clip, mechanical belt lock w/tools (not shown)

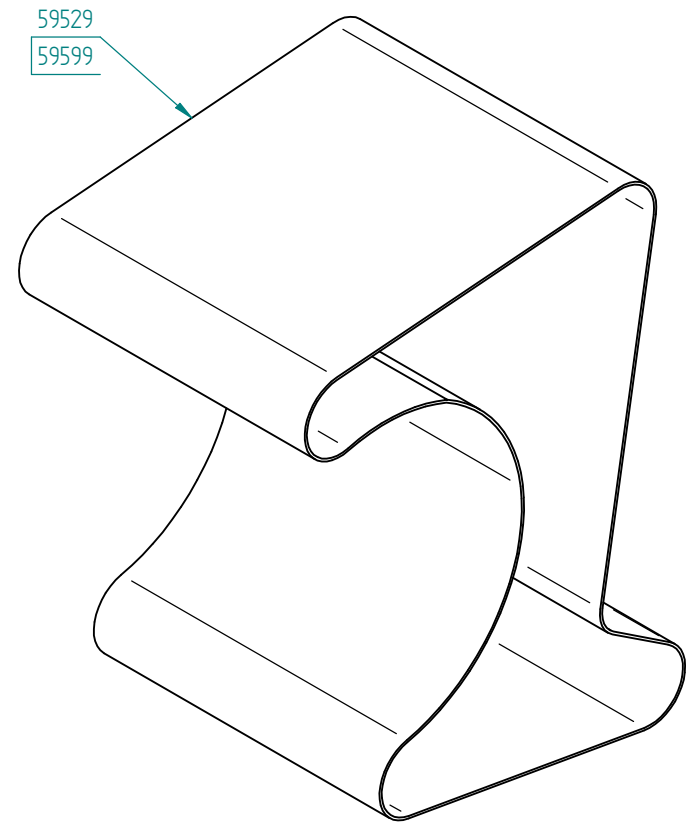
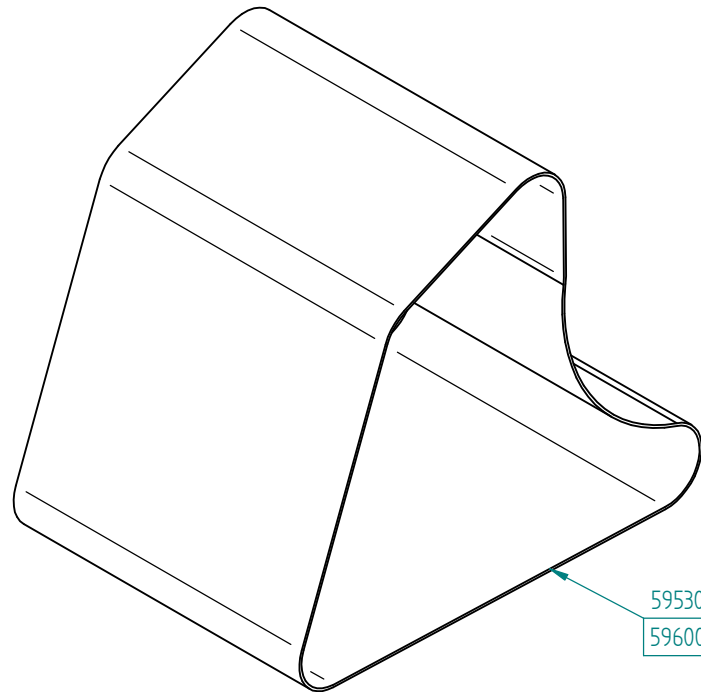



Part number	Qty	Description
59078	2	Cylinder 40x25x400
59098	2	Cylinder 60x35x800
59851	2	Cylinder 50x30x500

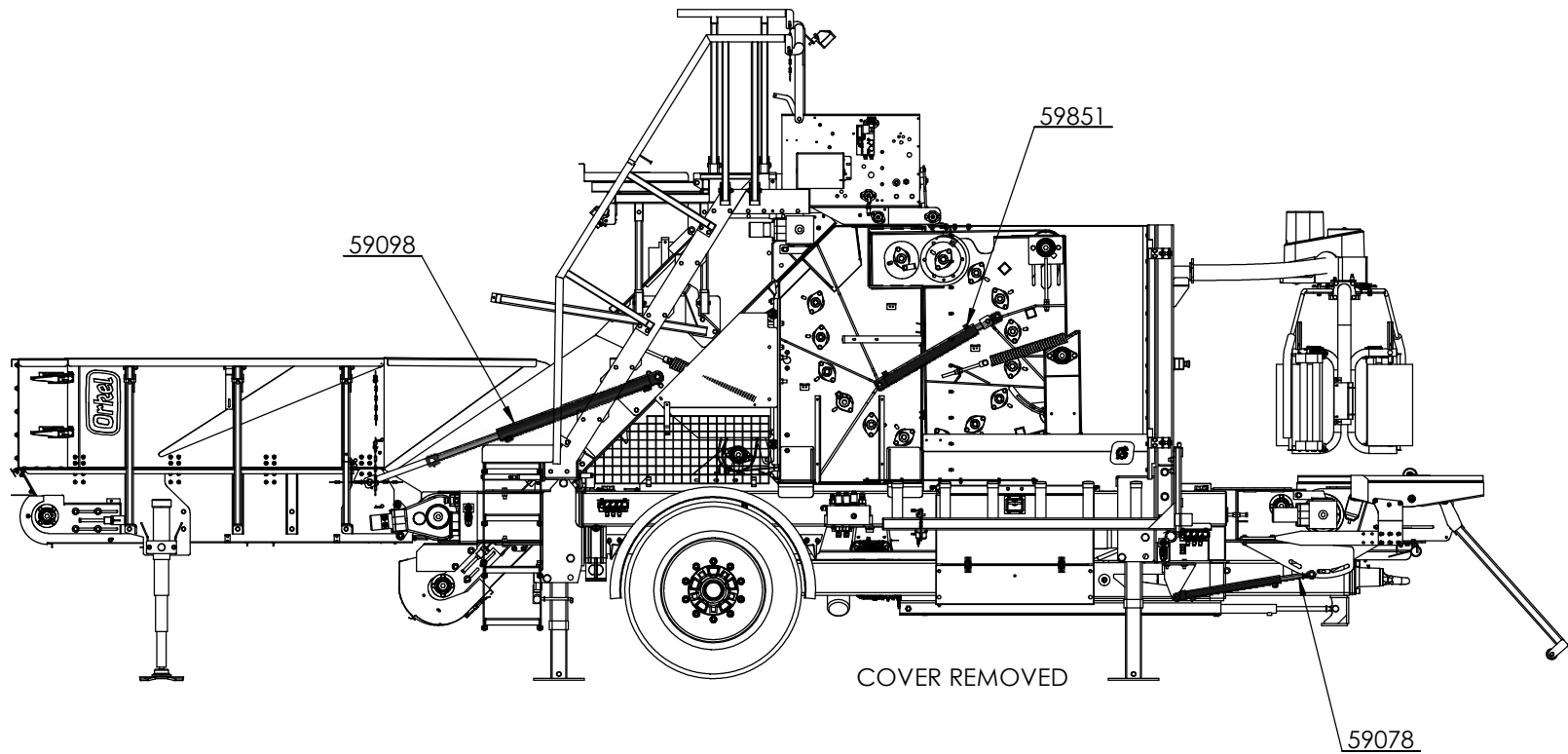

Part number	Qty	Description
59339	1	Filter element
59734	1	Suction filter

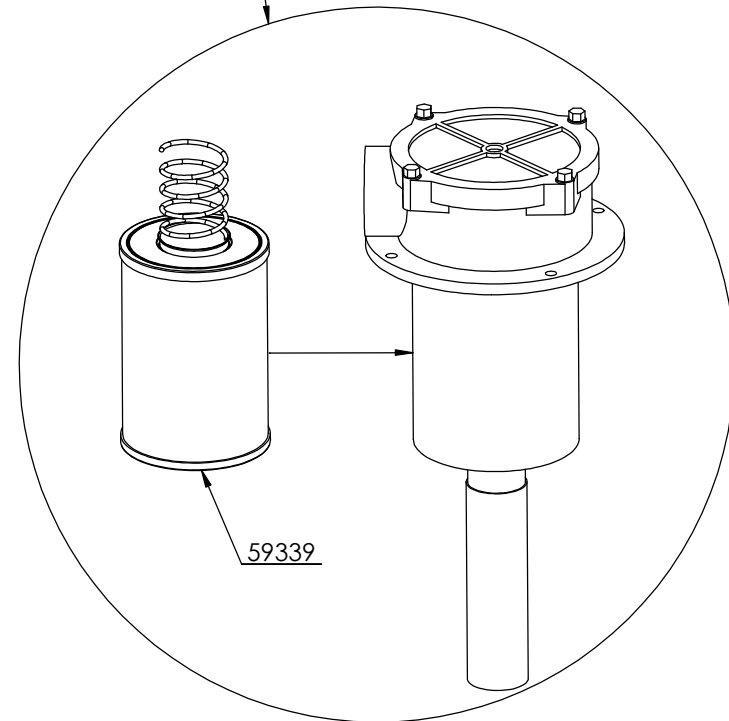
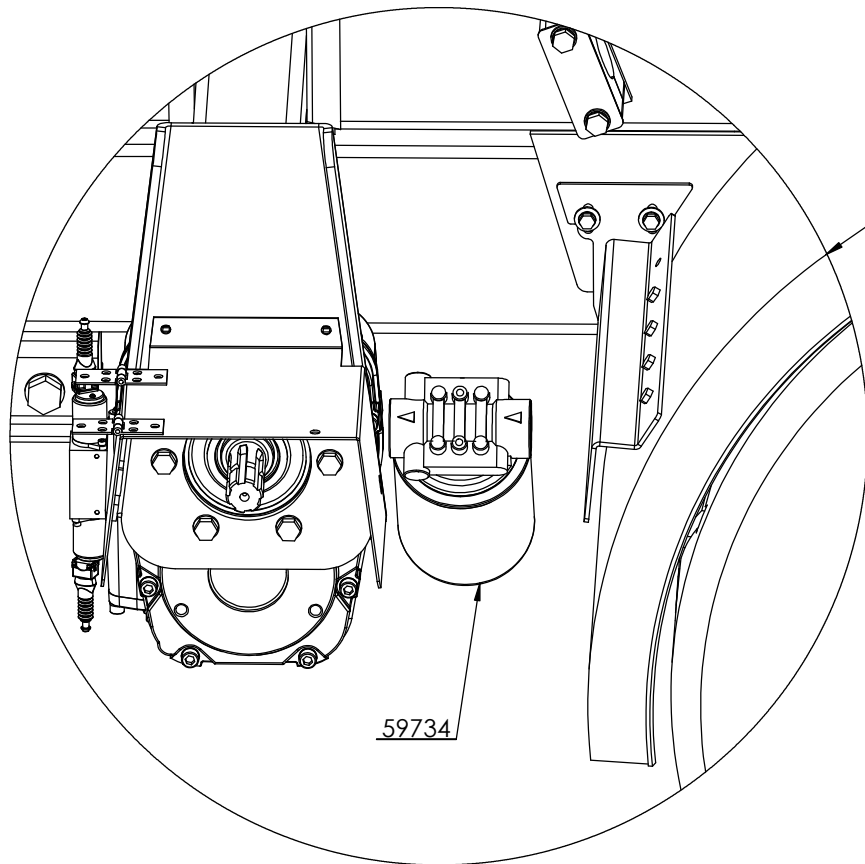
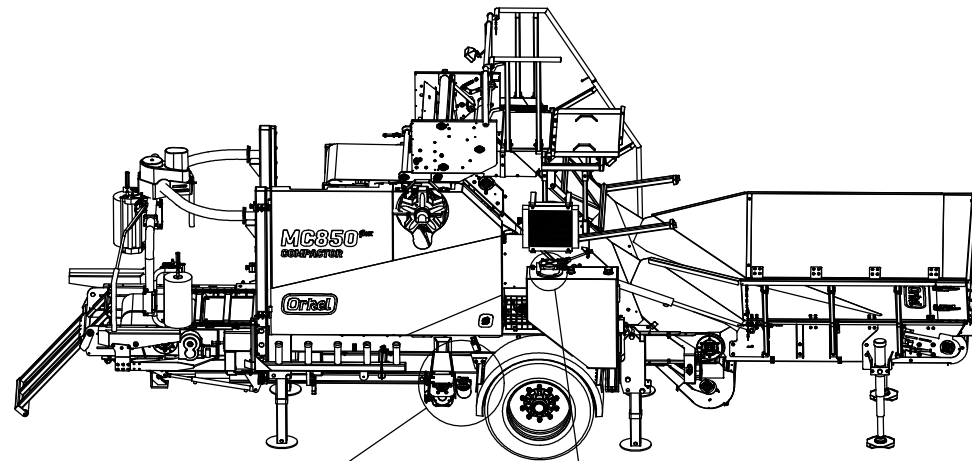

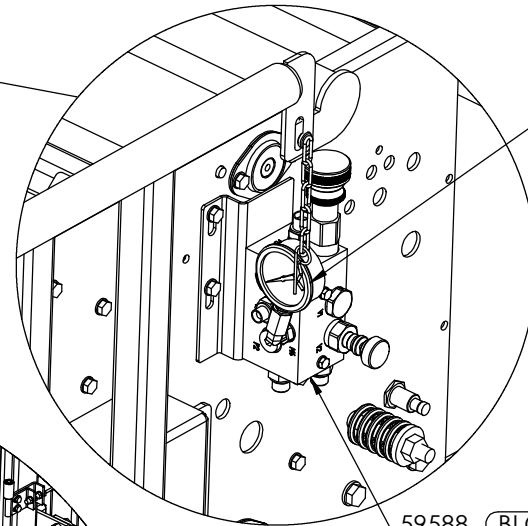
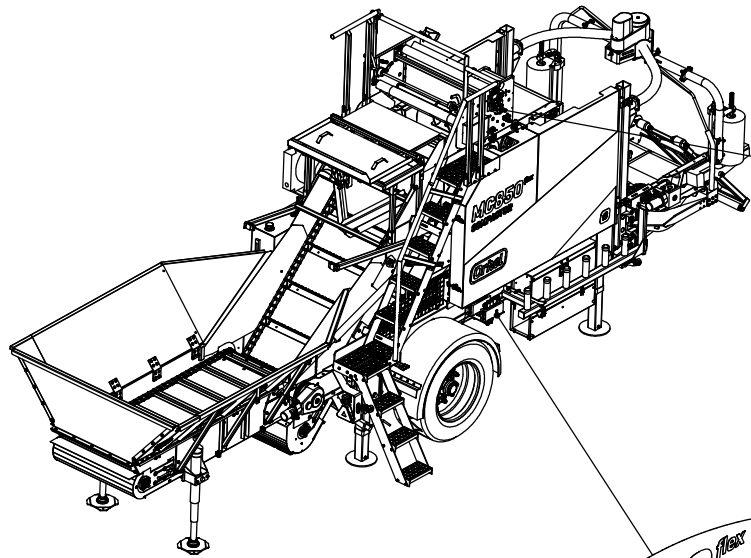

56755 MANOMETER

59588 BLOCK BRAKE - PAGE 9

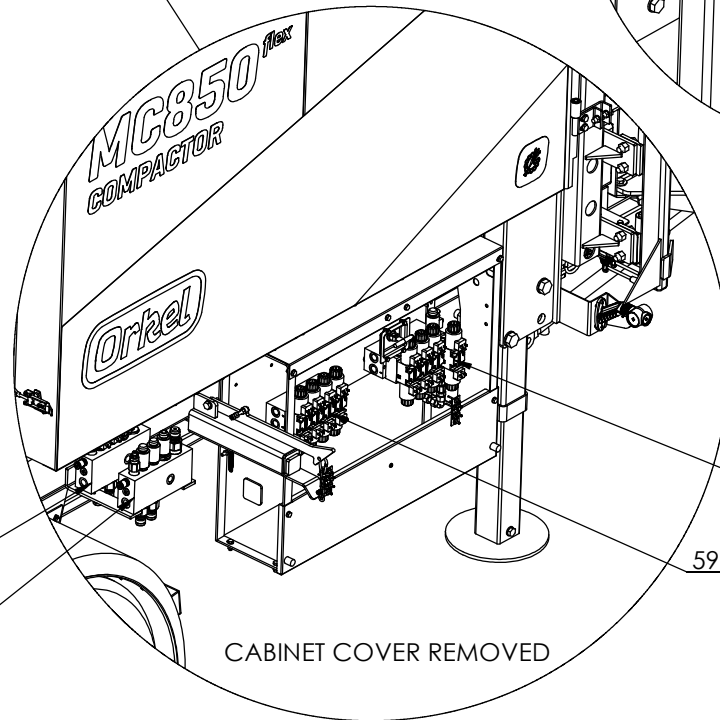

BLOCK 33.3 - PAGE 7 59097

BLOCK 33.4 - PAGE 8 59099

59096 BLOCK 33.2 - PAGE 6

59797 BLOCK 33.1 - PAGE 5

CABINET COVER REMOVED

Part Number	Qty.	Title
59797	1	Block 33.1 complete
59456	1	Body block 33.1
59461	1	Set screw 3/8"
59462	2	Directional valve DS3-S1/10N
59463	1	Directional valve DS3-S3/10N
59464	1	Directional valve DS3-S4/10N
59528	16	Bolt M5x30

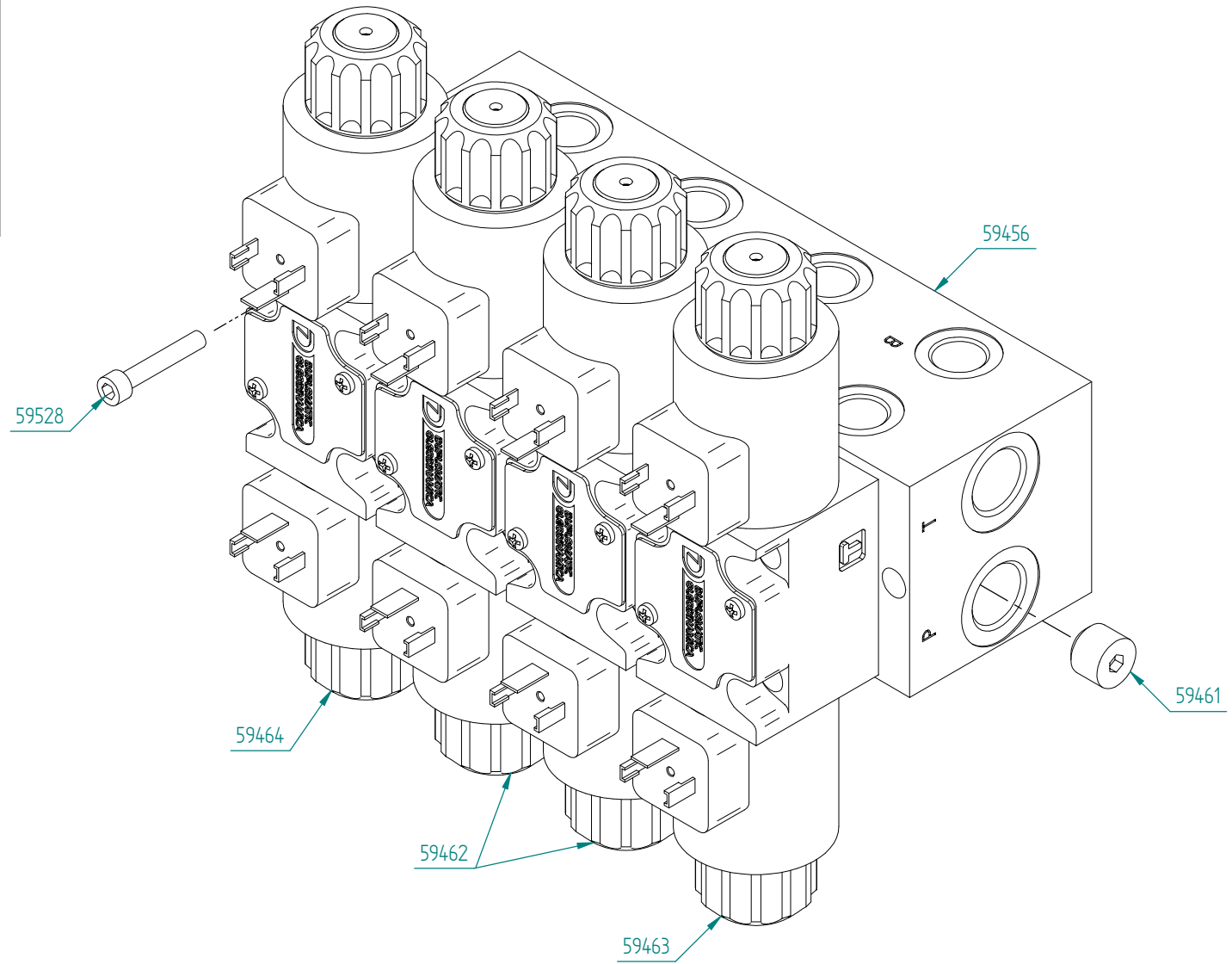

Block 33.1

Part Number	Qty.	Title
59096	1	Block 33.2 complete
57326	2	Globe valve NC ECD 30/2202
59458	1	Housing 30 Cft 34
59463	3	Directional valve Ds3-S3/10N
59464	1	Directional valve DS3-S4/10N
59466	3	Check valve MVPP-D/50
59467	2	Coil for 30-series 12Vdc Flucom
59468	1	Subplate NG06
59479	1	Pipe $\Phi 12 \times 1,5$ L=107
59482	1	Tee coupling
59526	12	Bolt M5x70
59527	4	Bolt M5x110
59946	1	Body block 33.2
59947	1	Restrictor 1/8" fine tune
59948	1	Coupling 10RL w/nut and 1/4" thread
59970	1	Coupling GE12LR 3/8" with seal
59971	1	Coupling EVW 12 L 90 dgr.
59972	1	Coupling GE10LR 1/8"
59973	1	Coupling GE12LR 1/4" with seal
59974	1	Coupling 1/8" male - 1/4" female
59975	1	Pipe $\Phi 12 \times 1,5$ L=40

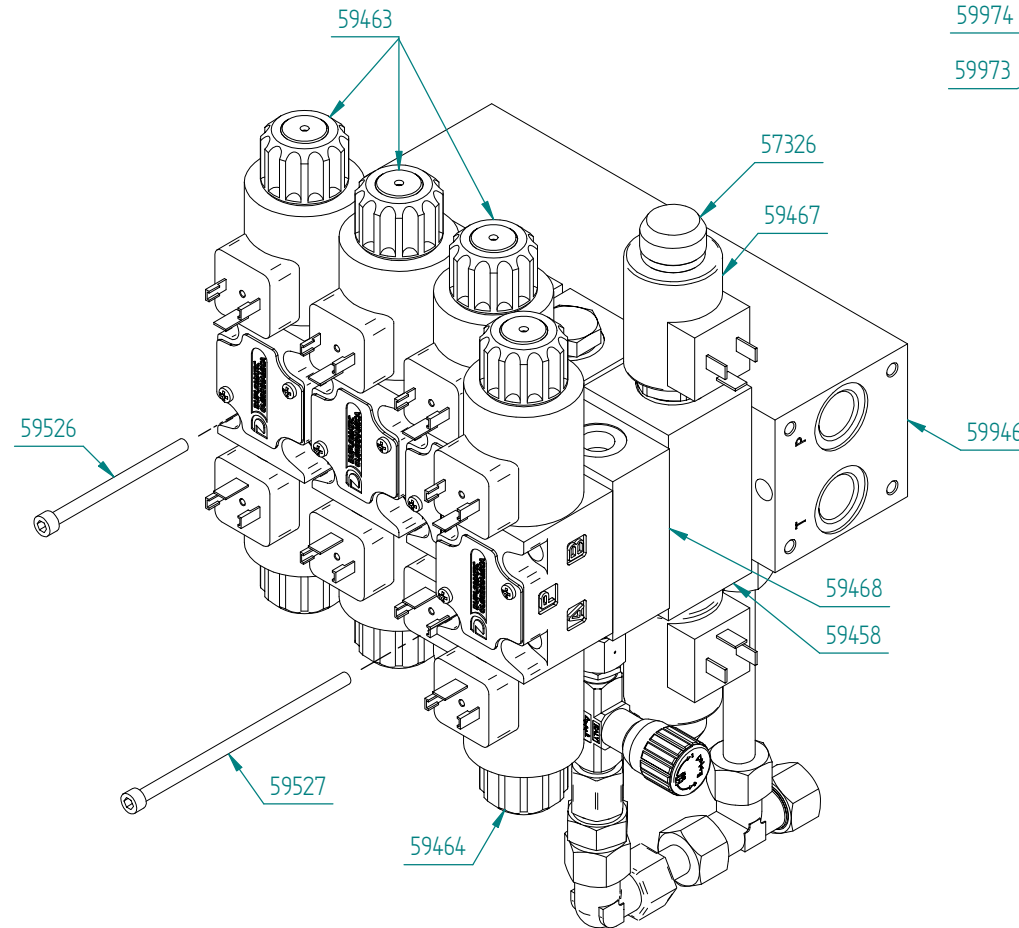
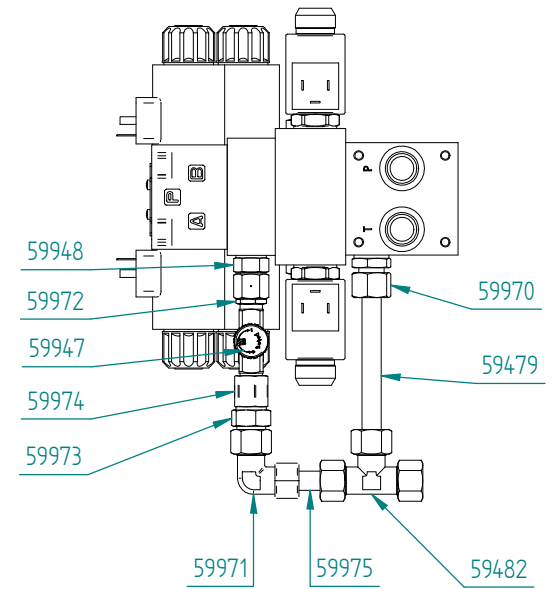
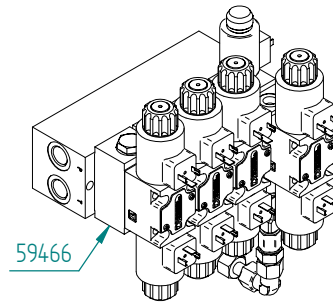

Block 33.2

Part Number	Qty.	Title
59097	1	Block 33.3 complete
59213	1	Test connection 1/4"
59459	1	Body block 33.3 and 33.4
59467	3	Coil for 30-series 12Vdc Flucom
59471	2	Flow control valve 3-way
59472	2	Globe valve NC EPP 30/22B2
59473	1	Globe valve NO EPP 50/22B1
59474	1	Relief valve LPB 30/D
59475	1	Plug BSP 1/4"
59476	1	Plug R 3/8"
59477	1	Plug R 1/2"
59478	1	PT50 Plug

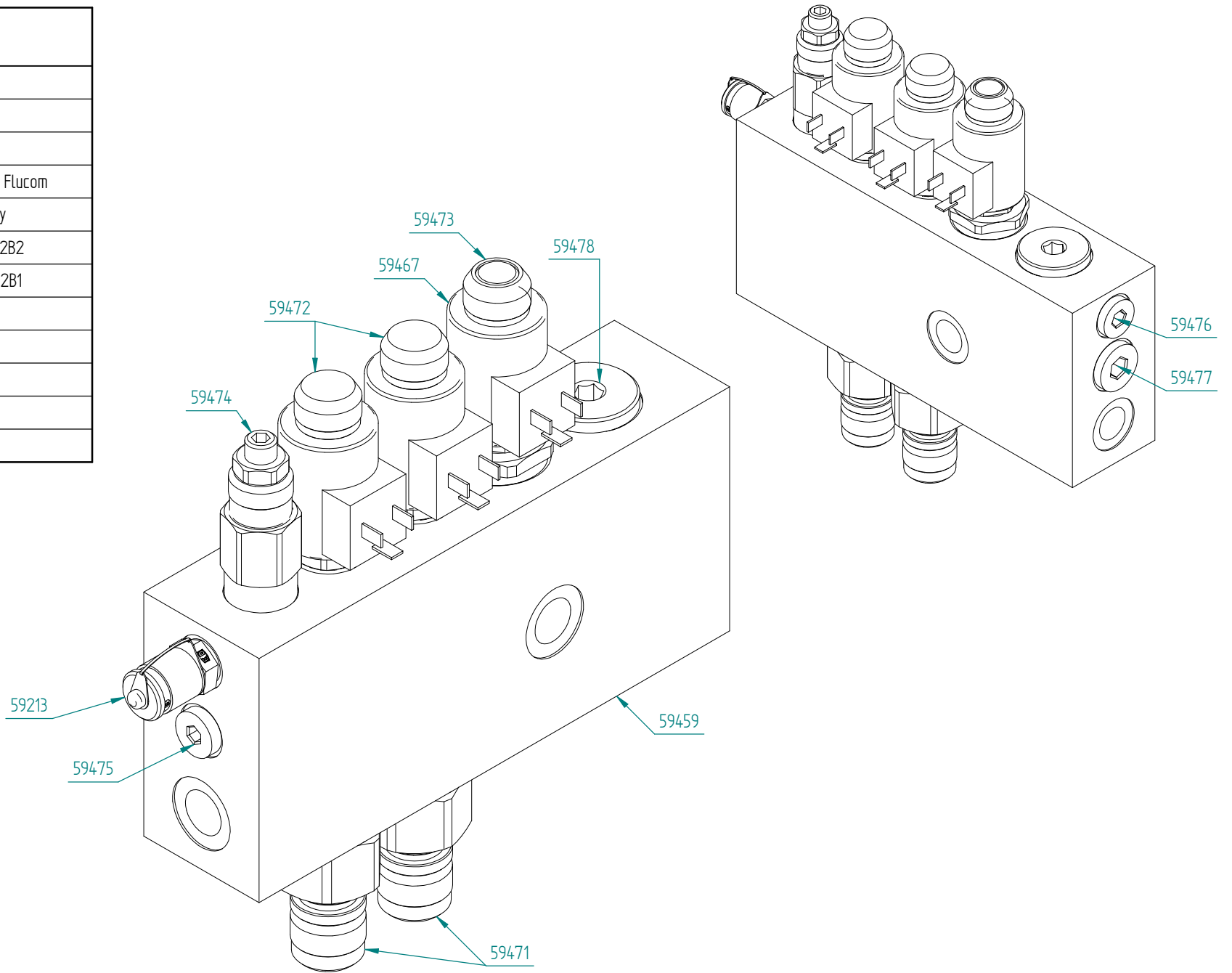

Block 33.3

Part Number	Qty.	Title
59099	1	Block 33.4 complete
59213	1	Test connection 1/4"
59459	1	Body block 33.3 and 33.4
59467	3	Coil for 30-series 12Vdc Flucom
59471	3	Flow control valve 3-way
59472	2	Globe valve NC EPP 30/22B2
59473	1	Globe valve NO EPP 50/22B1
59474	1	Relief valve LPB 30/D
59475	1	Plug BSP 1/4"
59476	1	Plug R 3/8"
59477	1	Plug R 1/2"

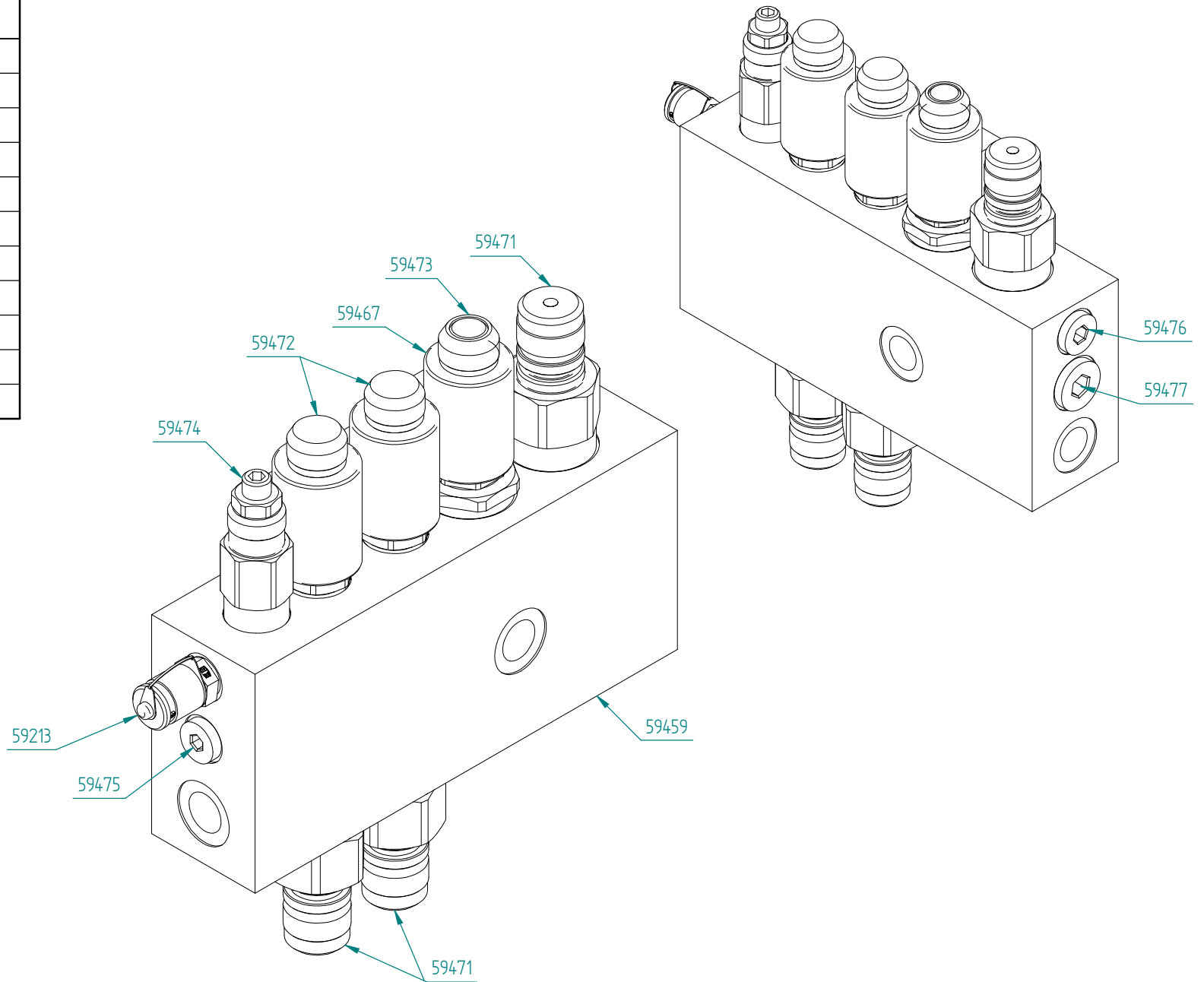

Block 33.4

Part Number	Qty.	Title
59588	1	Block for feeding and brake complete
10225	2	Bolt M6x90
12036	4	Washer M6
13208	2	Lock nut M6
35633	2	Bonded seal 1/4"
50605	4	Bonded seal 3/8"
56746	1	Block E1010005
56747	2	Flucom CAE30/P
56749	1	Plug 3/8"
57382	1	Elbow 1/4"
59177	2	Adaptor 3/8"-1/4"
59178	2	Adaptor 3/8"-3/8"
59191	1	Coupling 1/4"
59475	1	Plug BSP 1/4"
59589	1	Restrictor valve RDB 30/V
59706	1	Flucom LPA30/U-V

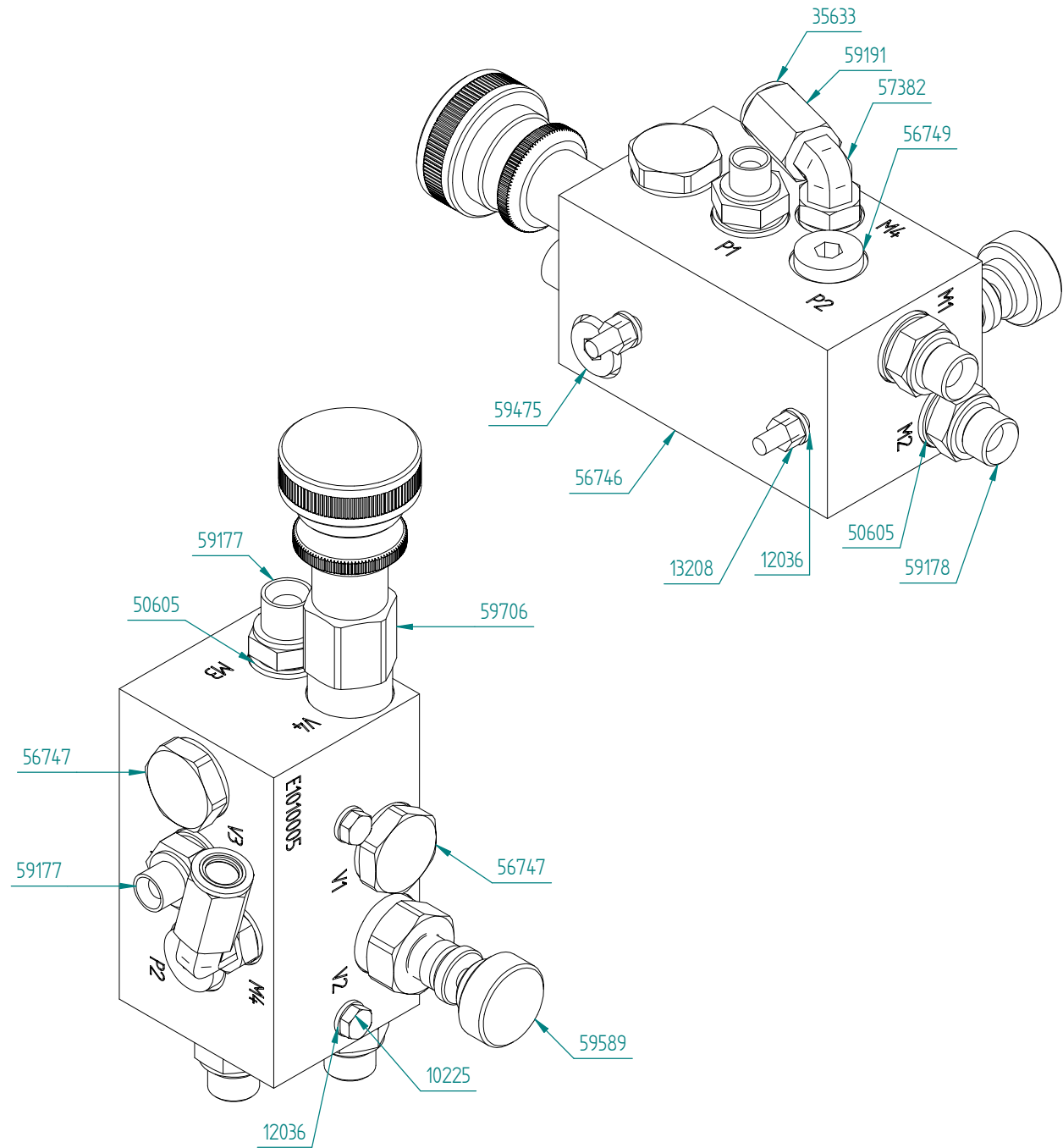

Block brake

<i>General hydraulic hoses</i>		
Part Number	Qty.	Title
59104	1	Hydraulic hose 1/4" 2SN L=860
59109	1	Hydraulic hose 1/4" 2SN L=870
59114	1	Hydraulic hose 3/8" 2SN L=365
59115	1	Hydraulic hose 3/8" 2SN L=1860
59128	1	Hydraulic hose 1/2" 2SN L=550
59130	1	Hydraulic hose 1/2" 2SN L=2000
59134	1	Hydraulic hose 1/2" 2SN L=1150
59137	1	Hydraulic hose 1/2" 2SN L=620
59143	1	Hydraulic hose 3/8" 2SN L=3610
59159	1	Hydraulic hose 3/8" 2SN L=440
59255	1	Hydraulic hose 1/4" 2SN L=800
59283	1	Hydraulic hose 1/2" 2SN L=1020
59288	1	Hydraulic hose 3/8" 2SN L=3740
59291	2	Hydraulic hose 1/4" 2SN L=1190
59295	2	Hydraulic hose 1/4" 2SN L=1040
59309	2	Hydraulic hose 1/4" 2SN L=390
59521	1	Hydraulic hose 1/2" 2SN L=1600
59523	1	Hydraulic hose 1/2" 2SN L=1800
59531	1	Hydraulic hose 3/8" 2SN L=1880

<i>General hydraulic hoses</i>		
Part Number	Qty.	Title
59532	1	Hydraulic hose 3/8" 2SN L=4620
59533	1	Hydraulic hose 3/8" 2SN L=2240
59534	1	Hydraulic hose 3/8" 2SN L=3820
59535	1	Hydraulic hose 1/4" 2SN L=3560
59537	1	Hydraulic hose 1/4" 2SN L=2120
59538	1	Hydraulic hose 1/4" 2SN L=1670
59539	1	Hydraulic hose 1/4" 2SN L=2980
59540	1	Hydraulic hose 3/8" 2SN L=1240
59541	2	Hydraulic hose 3/8" 2SN L=3130
59543	1	Hydraulic hose 1" 1SN L=730
59544	2	Hydraulic hose 1" 1SN L= 800
59545	1	Hydraulic hose 1" 1SN L=1560
59546	1	Hydraulic hose 1 1/2" 1SN L=3060
59547	2	Hydraulic hose 1/4" 2SN L=5200
59548	2	Hydraulic hose 1/2" 2SN L=1150
59551	2	Hydraulic hose 1/4" 2SN L=2150
59552	1	Hydraulic hose 1/2" 2SN L=2200
59553	1	Hydraulic hose 1/2" 2SN L=840
59555	1	Hydraulic hose 1/2" 2SN L=1850
59556	1	Hydraulic hose 1 1/4" 1SN L=950

<i>General hydraulic hoses</i>		
Part Number	Qty.	Title
59557	2	Hydraulic hose 1/4" 2SN L=2100
59558	1	Hydraulic hose 1/4" 2SN L=1830
59564	1	Hydraulic hose 1/4" 2SN L=2350
59566	1	Hydraulic hose 3/4 1SN L=2100
59583	2	Hydraulic hose 1" 4SH L=1670
59593	1	Hydraulic hose 1/2" 2SN L=620
59675	3	Hydraulic hose 1/4" 2SN L=3100
59676	1	Hydraulic hose 3/8" 2SN L=3500
59902	1	Hydraulic hose 1/2" 2SN L=950
80805	2	Hydraulic hose 1/4" 2SN L=2090
80806	1	Hydraulic hose 1/4" 2SN L=920
80807	1	Hydraulic hose 3/8" 2SN L=3060
80808	1	Hydraulic hose 1/2" 2SN L=720
80809	1	Hydraulic hose 1/2" 2SN L=600
80810	1	Hydraulic hose 1/4" 2SN L=2175
80811	1	Hydraulic hose 1/4" 2SN L=3090
80812	1	Hydraulic hose 1/2" 2SN L=1970
81054	1	Hydraulic hose 3/8" 2SN L=6400
81055	1	Hydraulic hose 3/8" 2SN L=6200
81056	1	Hydraulic hose 1/4" 2SN L=7700



All hydraulic hoses are marked with part number

<i>Hydraulic hoses for feed hopper F5</i>		
Part Number	Qty.	Title
59111	1	Hydraulic hose 1/4" 2SN L=2610
59152	1	Hydraulic hose 1/4" 2SN L=1070
59153	1	Hydraulic hose 1/4" 2SN L=930
59281	1	Hydraulic hose 3/8" 2SN L=4360
59282	1	Hydraulic hose 3/8" 2SN L=4465
59562	2	Hydraulic hose 1/4" 2SN L=3090
80970	1	Hydraulic hose 1/4" 2SN L=3110

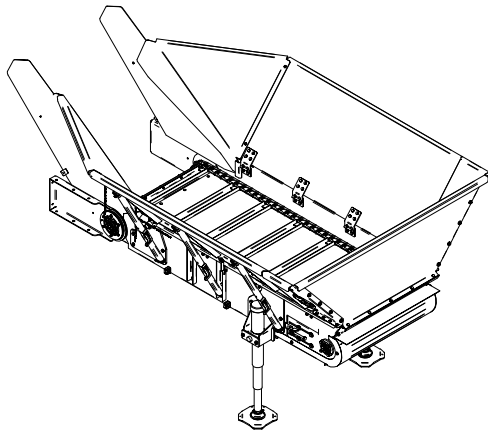

<i>Hydraulic hoses for plastic tying unit</i>		
Part Number	Qty.	Title
59146	4	Hydraulic hose 1/4" 2SN L=740
59559	1	Hydraulic hose 3/8" 2SN L=2200
59560	1	Hydraulic hose 1/4" 2SN L=920
59561	2	Hydraulic hose 3/8" 2SN L=700
59626	1	Hydraulic hose 3/8" 2SN L=245
59627	1	Hydraulic hose 3/8" 2SN L=315
59628	1	Hydraulic hose 3/8" 2SN L=355
59669	1	Hydraulic hose 3/8" 2SN L=400
59672	2	Hydraulic hose 1/4" 2SN L=350
59673	1	Hydraulic hose 1/4" 2SN L=500

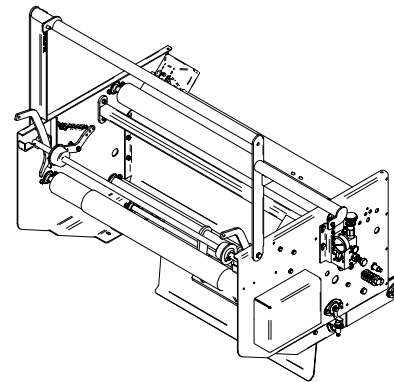

Hydraulic hoses

All hydraulic hoses are marked with part number

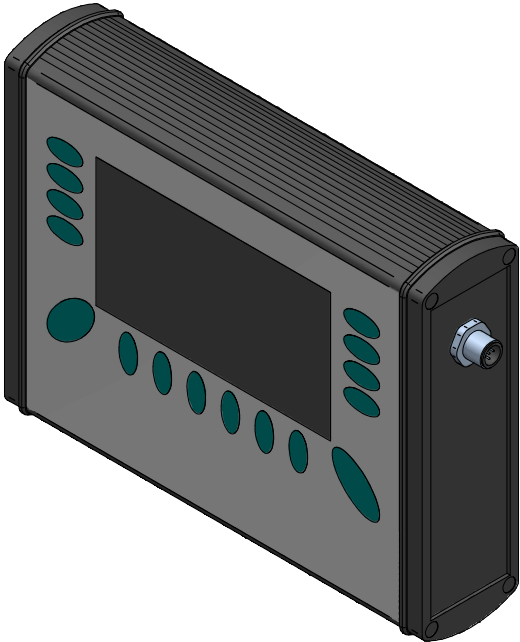
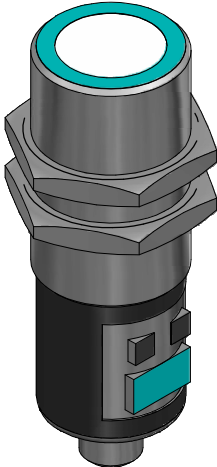
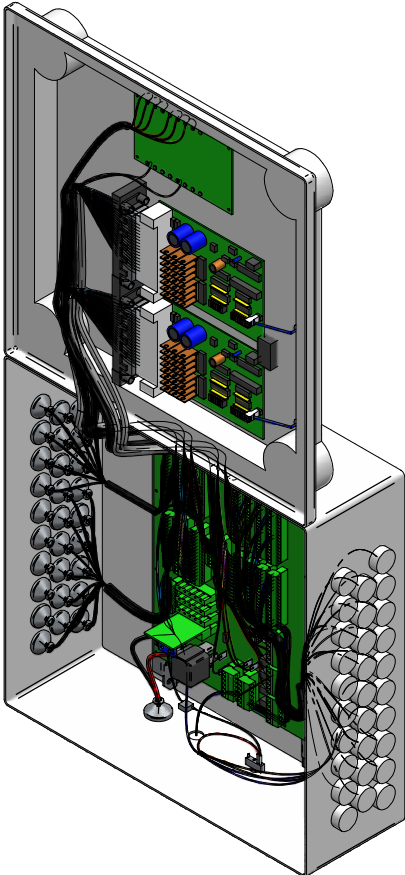

- S1 - Bale on wrap table
- S3 - Table middle position
- S5 - Wrap arm home position
- S8 - Wrap arm stop
- S9 - Table lower position
- S10 - Table upper position
- S11 - Film sensor 1
- S12 - Film sensor 2
- S15 - Bale size controller
- S17 - Chamber opened
- S18 - Chamber closed
- S19 - Feed rollers opened
- S20 - Feed rollers closed
- S21 - Feed hopper control
- S22 - Net knife closed
- S26 - Oil Temp
- S27 - Oil Level
- S30 - Chamber pressure
- S31 - Chamber speed
- S32 - Net control

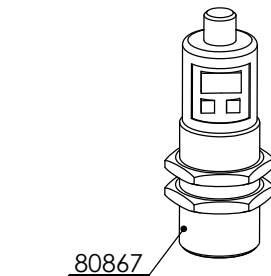
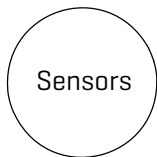
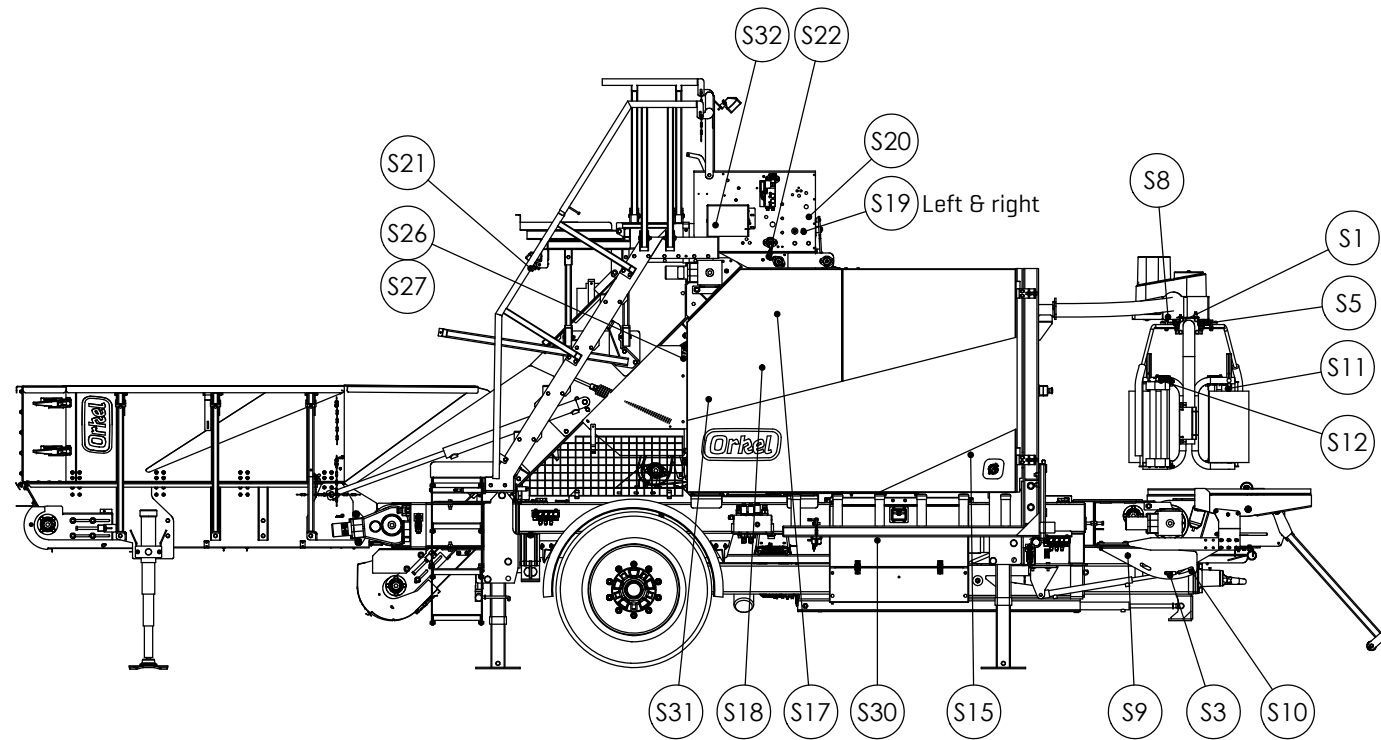

Ultrasonic sensor

- S1
- S21

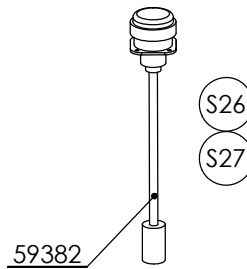

Level/temperature watch

- S26
- S27

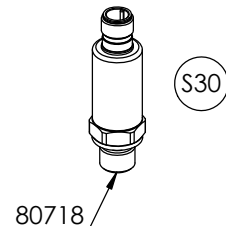

Pressure sensor 0-600 bar

- S30

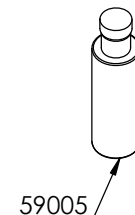

Inductive transducer

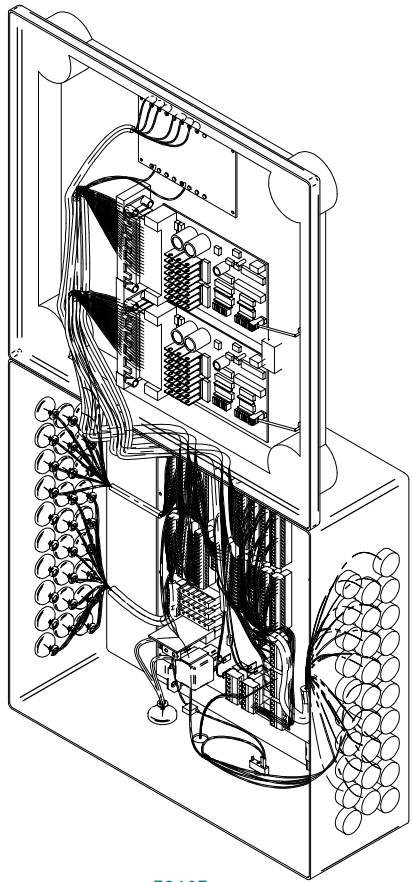

59605
Electro cabinet, complete

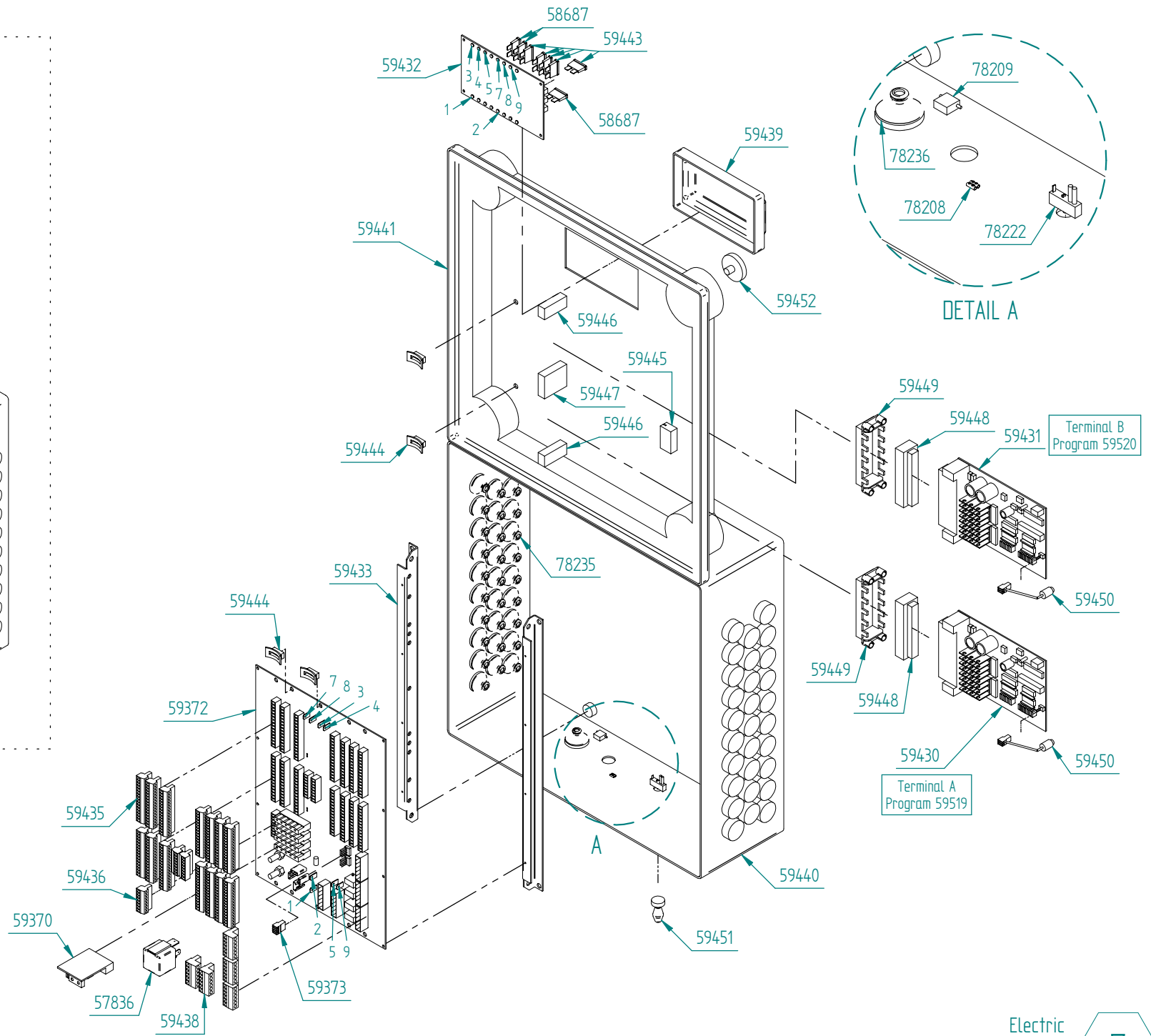

Cabinet

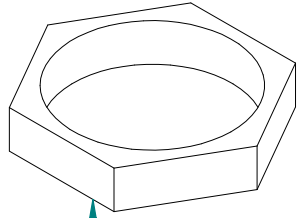

55885 Nut for PG 13

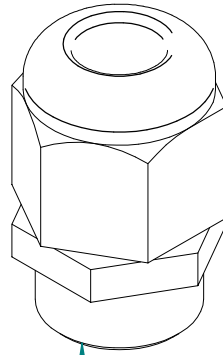

56123 Cable gland PG 13

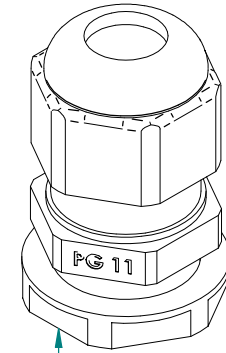

54558 Cable gland PG 11

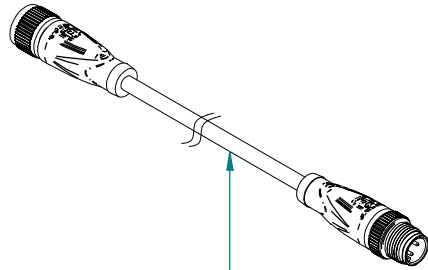

58024 Control cable, 5 meter

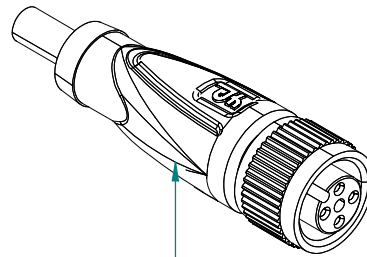

59006 Sensor cable 4-lead

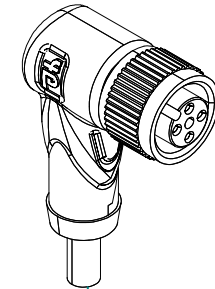

59007 Sensor cable

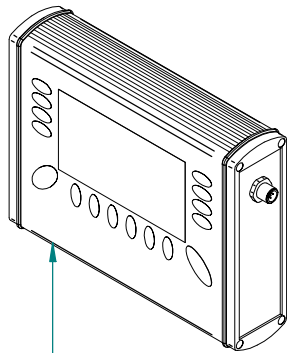

59364 Control box

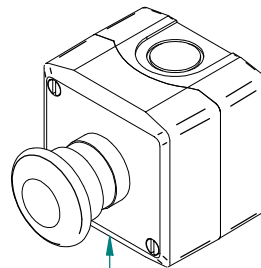

80004 Emergency switch

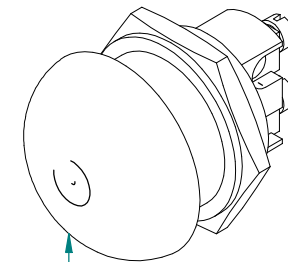

59045 Switch

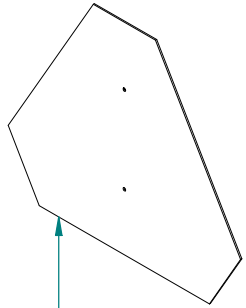

35618 Warning triangle, large

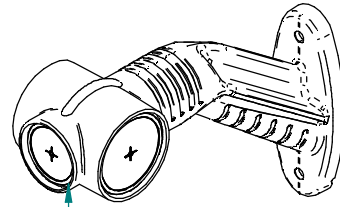

81038 Marker light, left LED

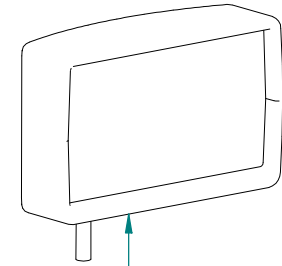

59581 Flood light

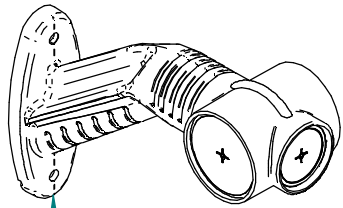

81039 Marker light, right LED

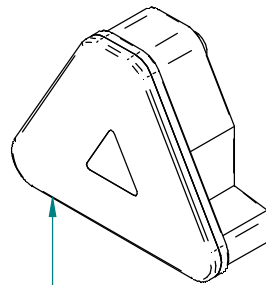

81037 Agripoint Full LED 5 pin connector

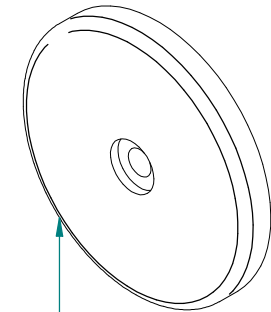

14901 Reflector ø60 white

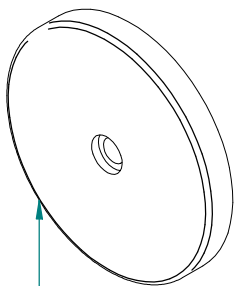

59410 Reflex ø60, orange

Part Number	Qty.	Title
14901	2	Reflector ø60 white
81038	2	Marker light, left LED
14927	8	Light bulb 12V/ 5W
35618	1	Warning triangle, large
81037	2	Agripoint Full LED 5 pin connector
54558	1	Cable gland PG 11
55885	5	Nut for PG 13
56123	5	Cable gland PG 13
57836	1	Relay 12V 70A
57849	1	Jack
58002	7	Cable 2 x 6 mm2 (per meter)
58023	1	Cable set, complete, battery
58024	1	Control cable, 5 meter
58201	1	Fuse holder For For Maxi-w/cover
58687	3	Fuse 10A
59005	15	Inductive transducer
59006	9	Sensor cable 4-lead
59007	7	Sensor cable
59045	1	Switch
81039	2	Marker light, right LED
59364	1	Control box
59370	1	Regulator 0-2A
59372	1	Motherboard
59373	1	Contact bus, w/cable

Part Number	Qty.	Title
59410	2	Reflex ø60, orange
59430	1	Terminal card A
59431	1	Terminal card B
59432	1	Fuse card
59433	2	Rail, motherboard
59435	14	Terminal 16
59436	3	Terminal 8
59438	5	Terminal 6
59439	1	Plastic cover, hatch
59440	1	Electric cabinet, box
59441	1	Electric cabinet, lid
59443	5	Fuse 15A
59444	4	Cable seat
59445	1	Fastening block 1
59446	2	Fastening block 2
59447	1	Fastening block 3
59448	2	Terminal card, contact
59449	2	Terminal card, contact holder
59450	2	Contact bus diode
59451	1	Light switch
59452	1	Magnet ø32 with base
59581	2	Flood light
59614	7	Cable 3 x 1,5 mm2 (per meter)
59615	39	Cable 2 x 0,75 mm2 (per meter)

Part Number	Qty.	Title
59780	1	Wire, light set
59794	8	Cable 7 x 1,5 mm2 (per meter)
59795	6	Cable 2 x 10 mm2 (per meter)
59873	2	Grommet Double Flanged 16x24x30mm
78208	1	Bit
78209	1	Block
78222	1	Light switch, box
78235	58	Plug 1
78236	1	Plug 2
80004	5	Emergency switch
80206	1	Fuse 2A medium
80270	1	Fuse holder with cable
80596	1	Fuse 20 amp, Maxi
80718	1	Pressure sensor 0-600 bar
80867	2	Ultrasonic sensor

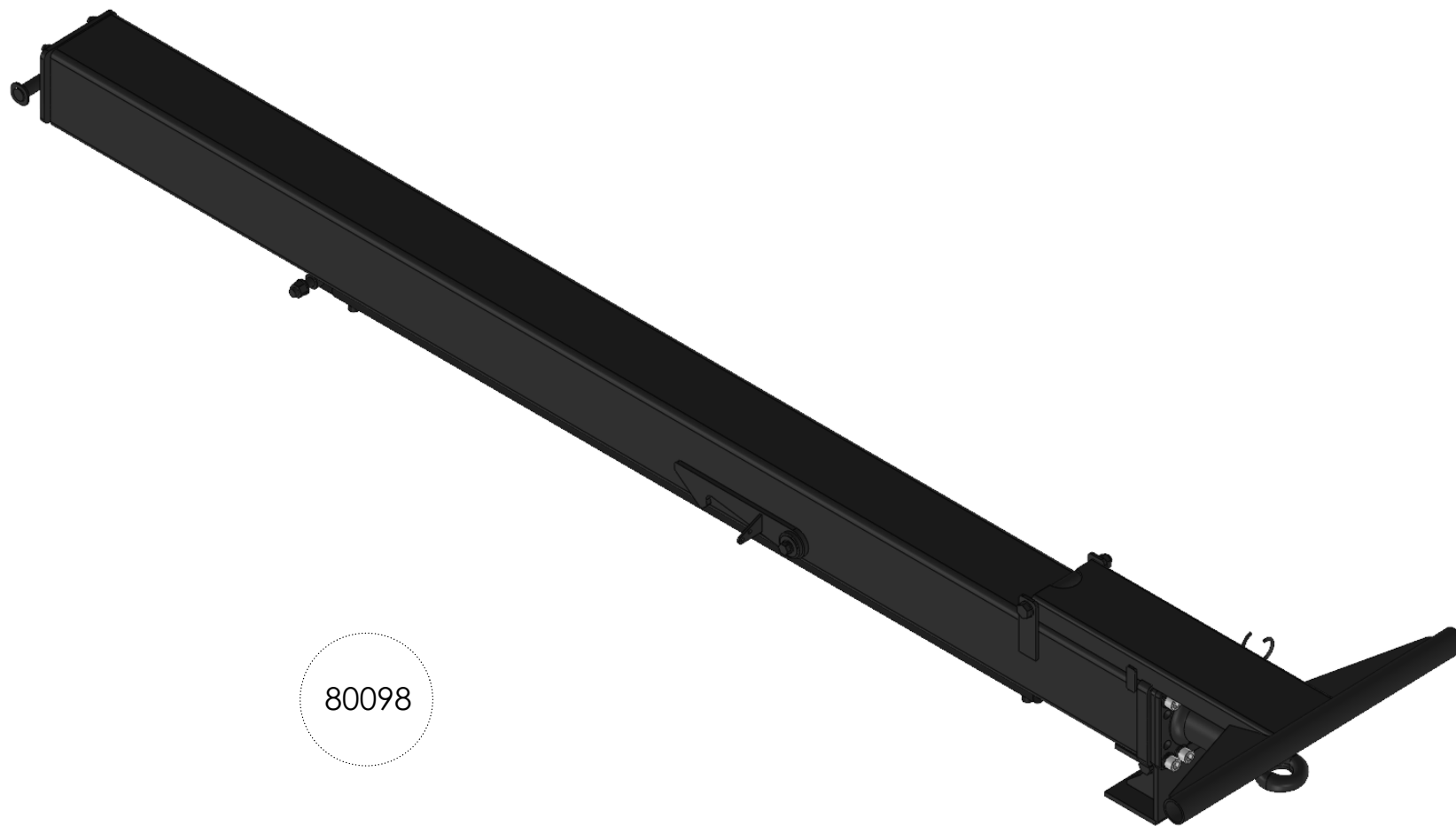

80098

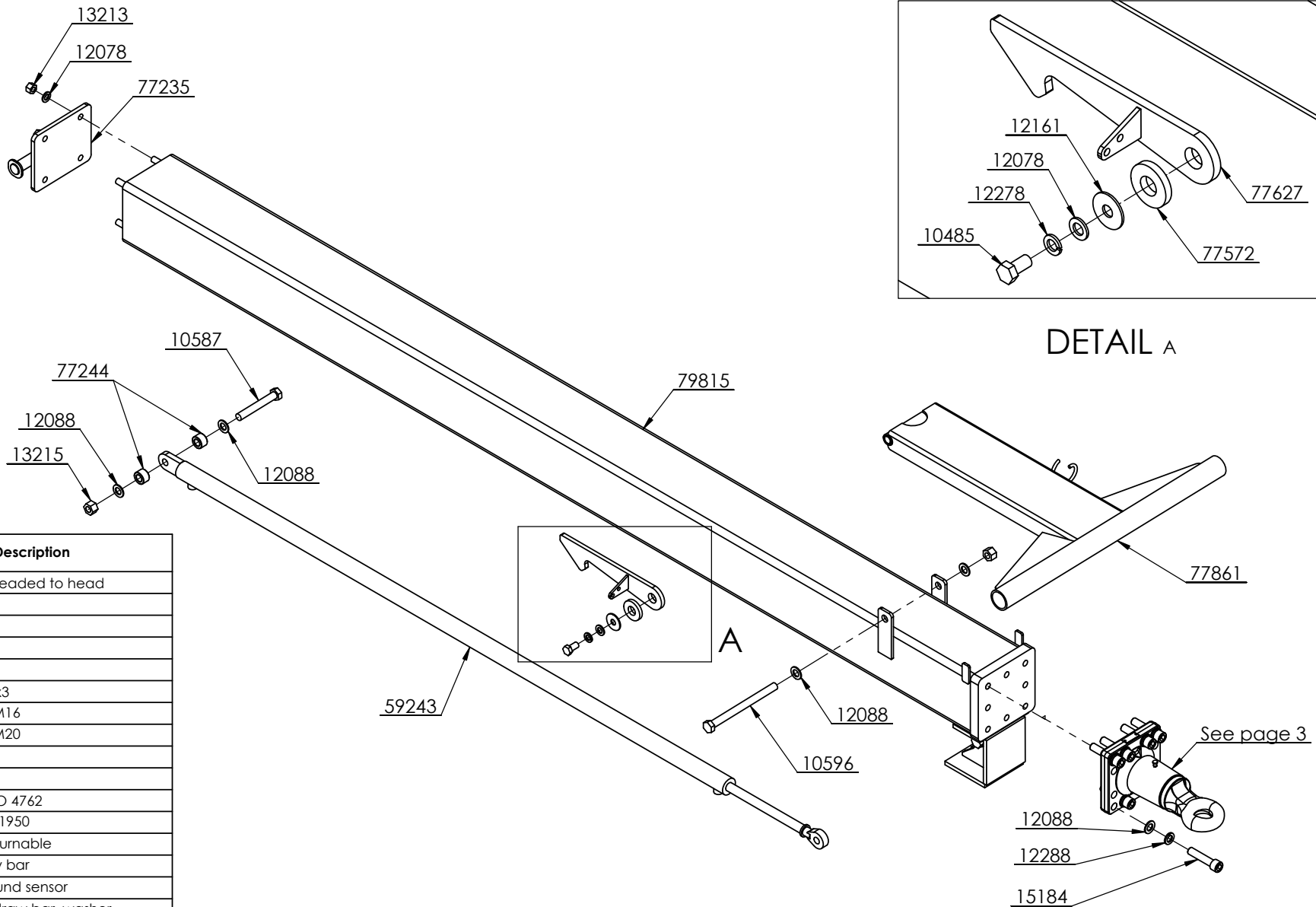

Part number	Qty	Description
10485	1	Bolt M16x30, threaded to head
10587	1	Bolt M20x140
10596	1	Bolt M20x250
12078	9	Washer M16
12088	14	Washer M20
12161	1	Washer ø50/17x3
12278	1	Spring washer M16
12288	8	Spring washer M20
13213	4	Lock nut M16
13215	3	Lock nut M20
15184	8	Bolt M20 x 90 ISO 4762
59243	1	Cylinder 50x30x1950
59277	1	Draw bar eye, turnable
77235	1	End plate, draw bar
77244	2	Spacer, ultrasound sensor
77572	1	Locking hook, draw bar, washer
77627	1	Locking hook, draw bar
77861	1	Wrapper support
79815	1	Draw bar, MC

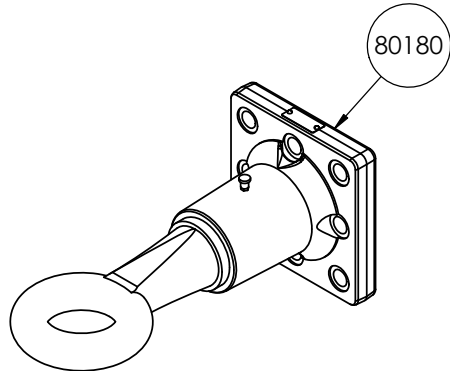
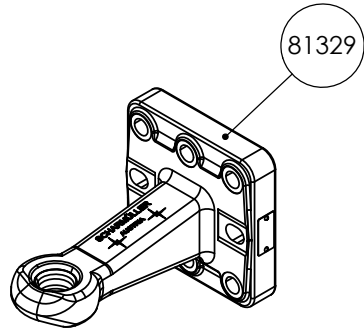
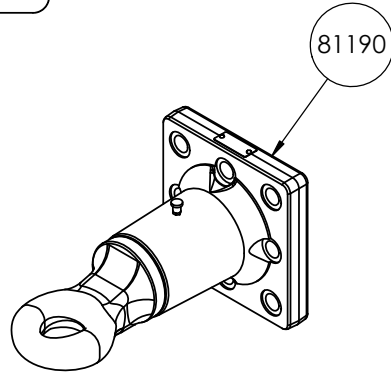
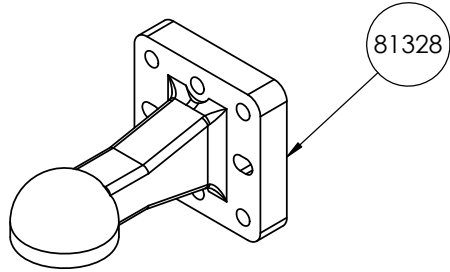
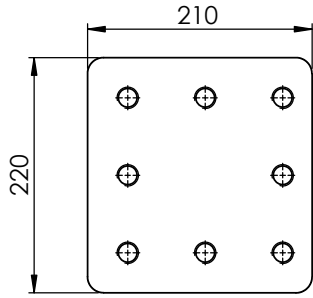

Part number	Qty	Description
81190	1	Draw bar eye, turnable, ø50
81328	1	Drawbar eye, ball
81329	1	Drawbar eye, euro, ø40
80180	1	Drawbar eye, ø76

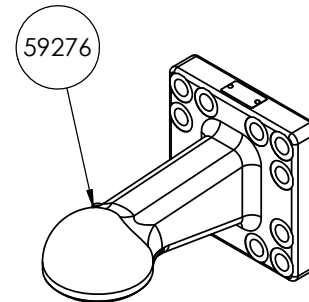
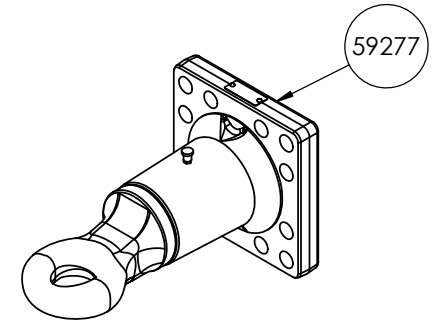
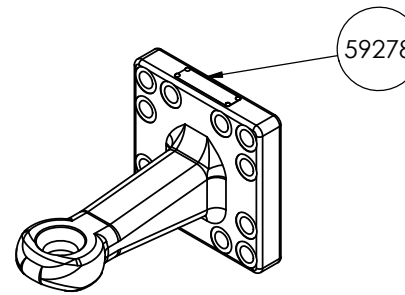
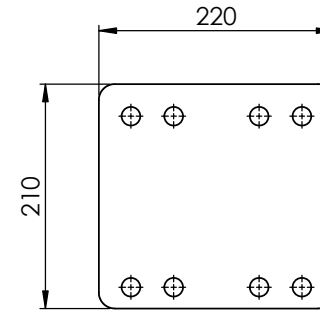

Part number	Qty	Description
59276	1	Draw bar eye, ball
59277	1	Draw bar eye, turnable, ø50
59278	1	Drawbar eye, euro, ø40

Part number	Qty	Description
78624	1	PTO drive shaft, wide angle, 6-spline
59033	1	PTO drive shaft, standard, 6-spline
81172	1	PTO drive shaft, wide angle, 8-spline
80949	1	PTO drive shaft, standard, 8-spline
81086	1	PTO drive shaft, wide angle, 21-spline
81092	1	PTO drive shaft, standard, 21-spline

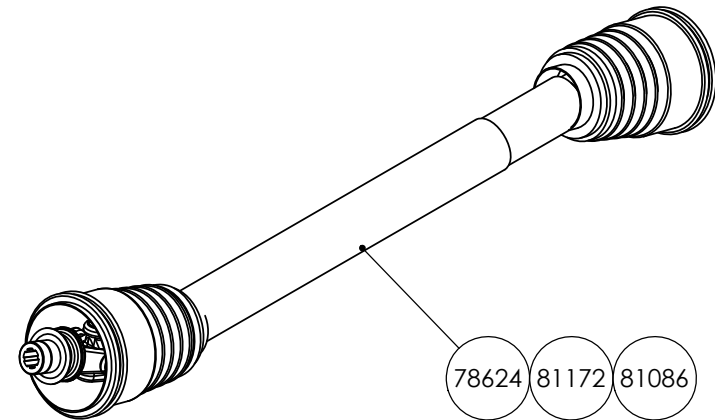
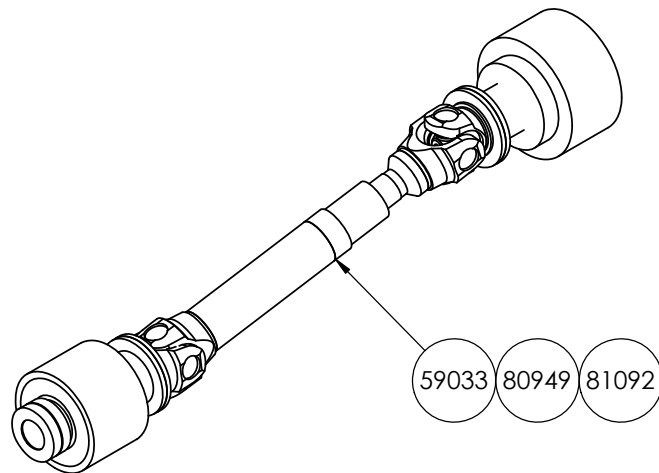

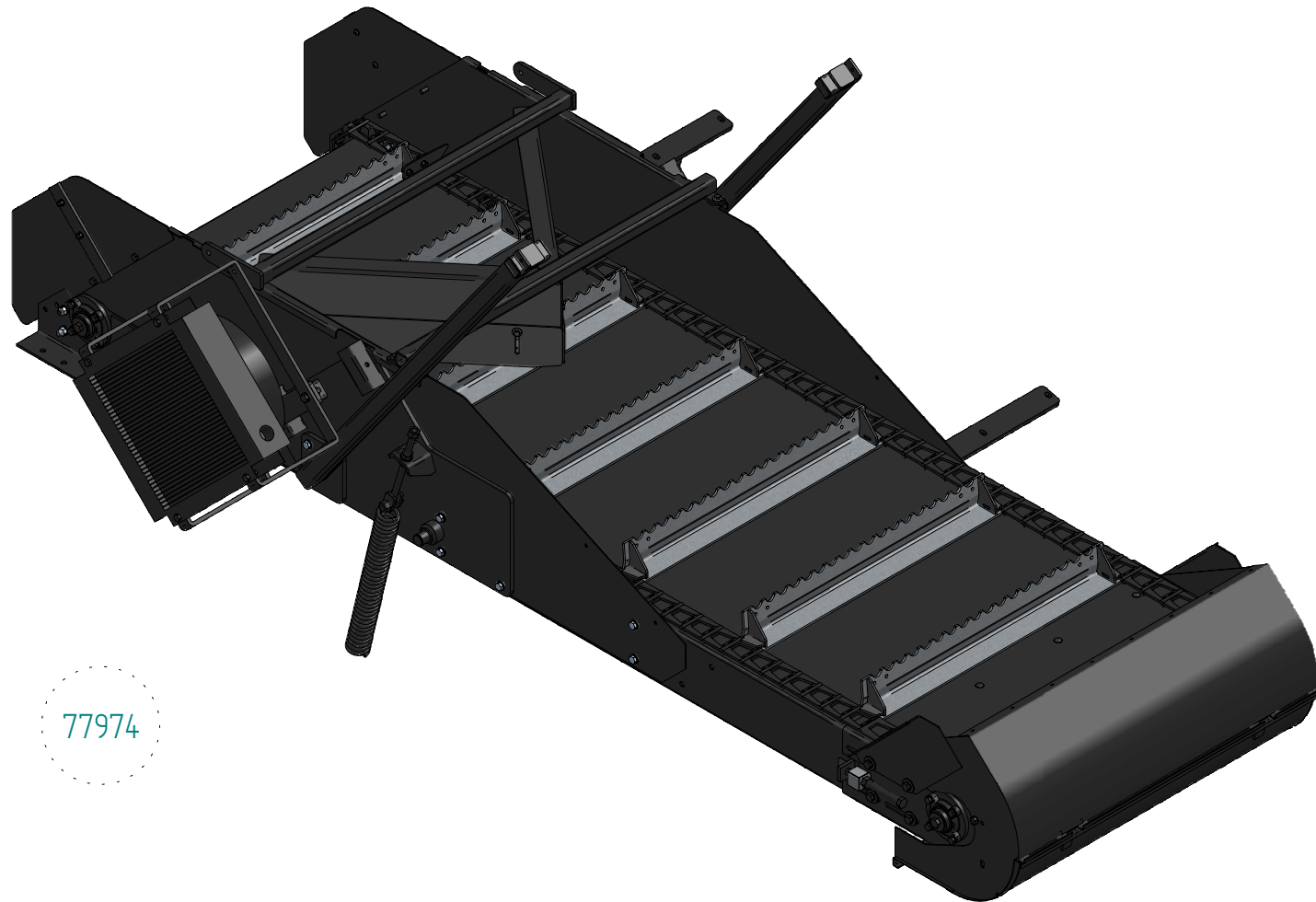

77974

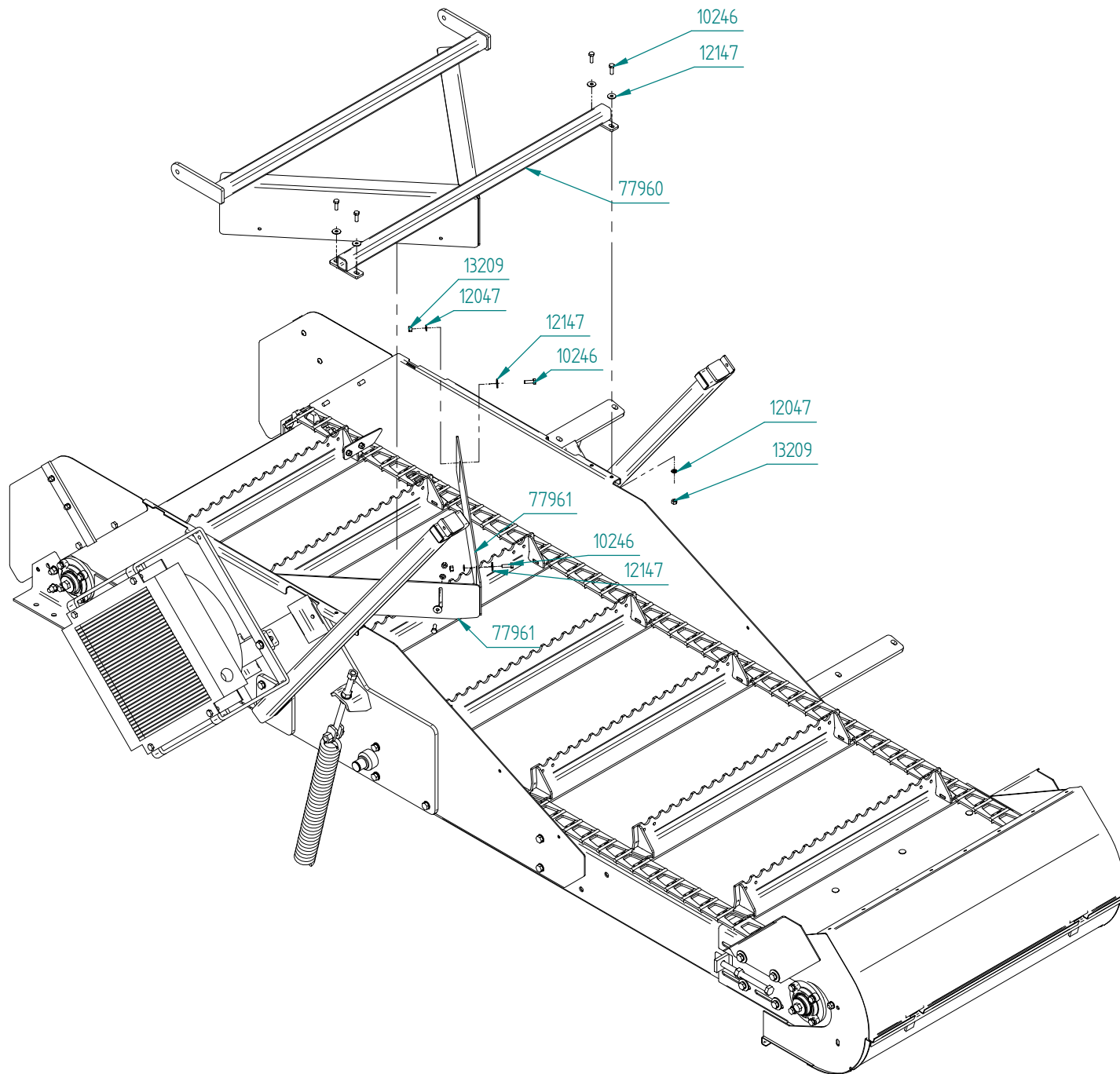

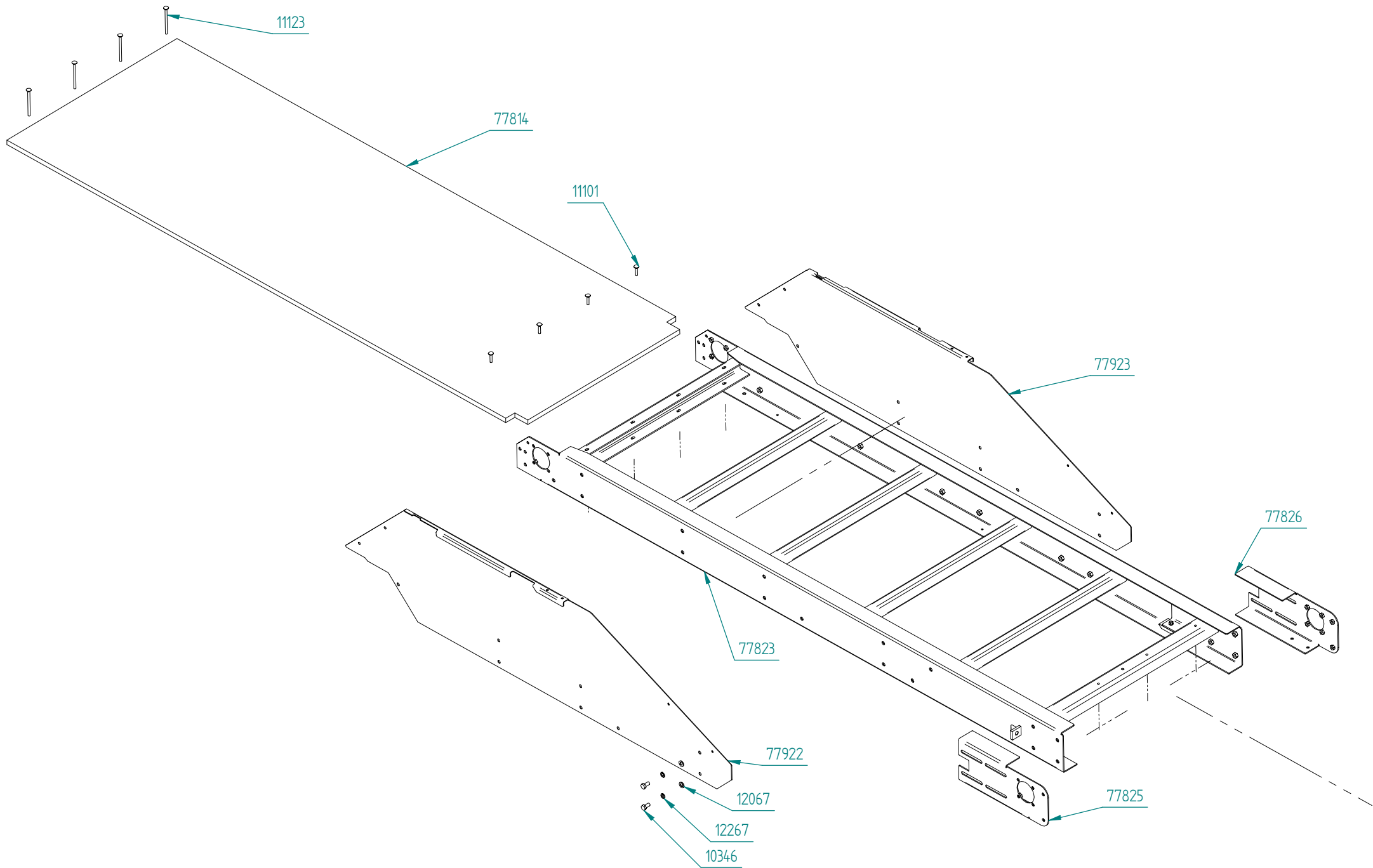

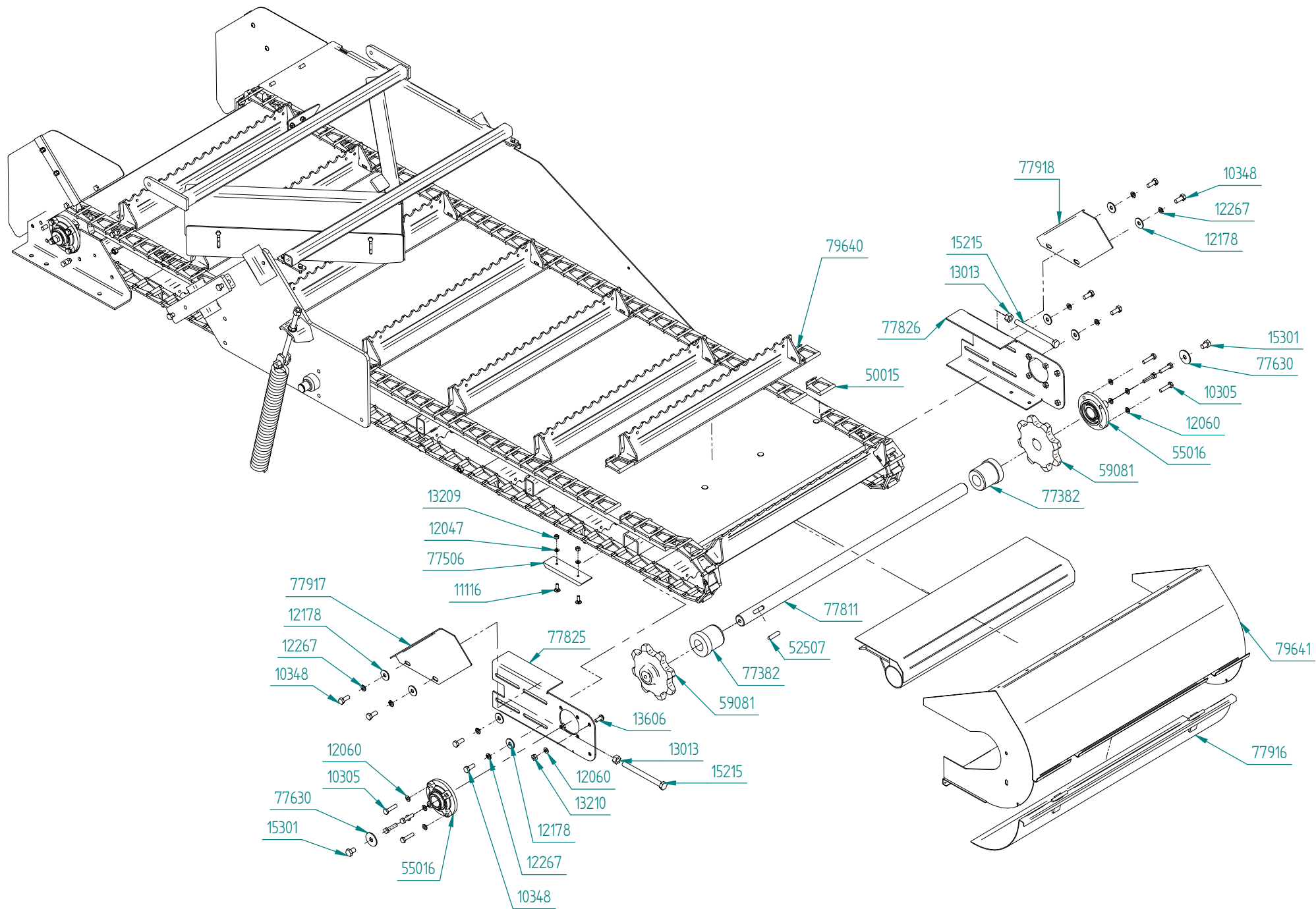

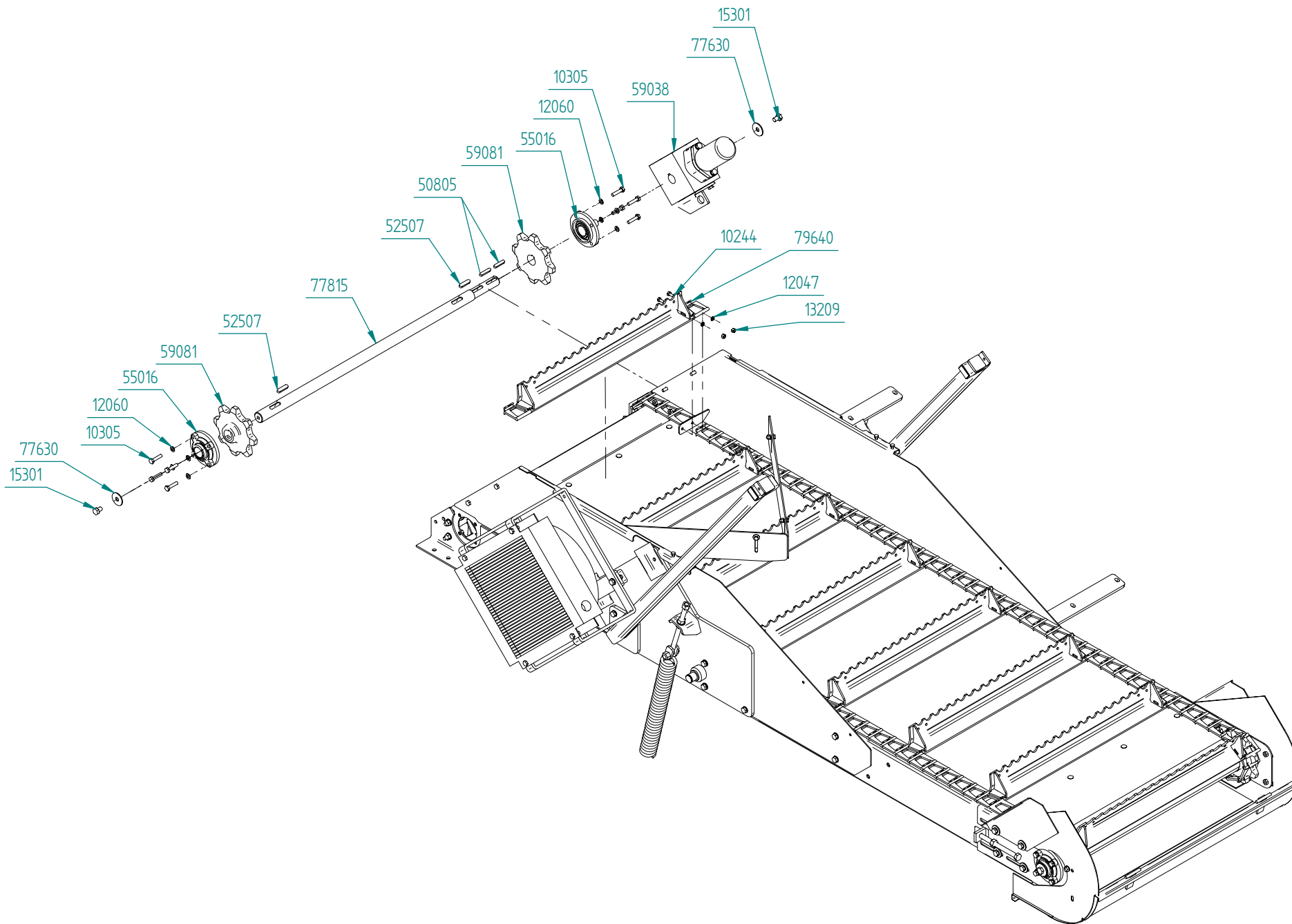

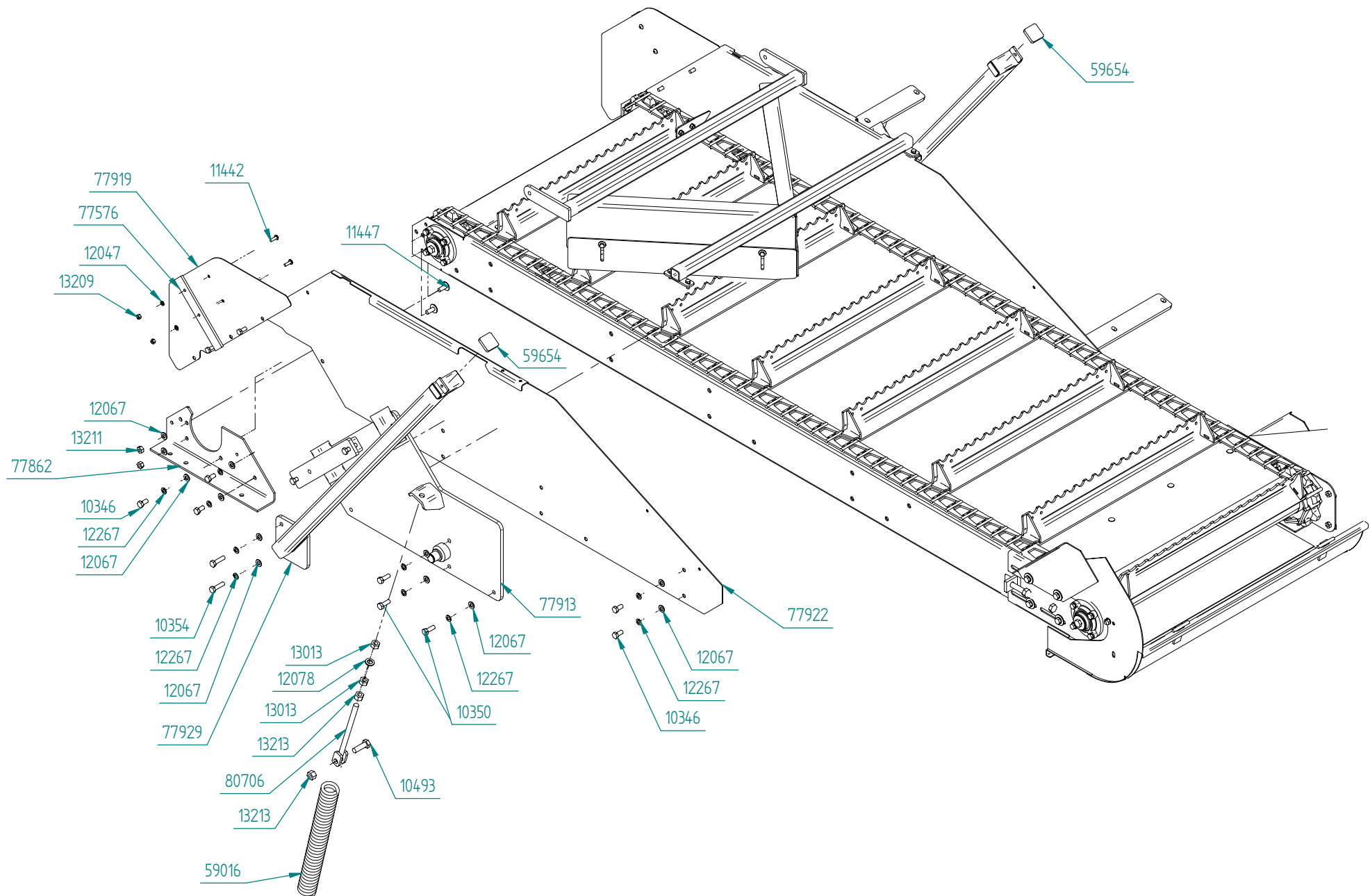

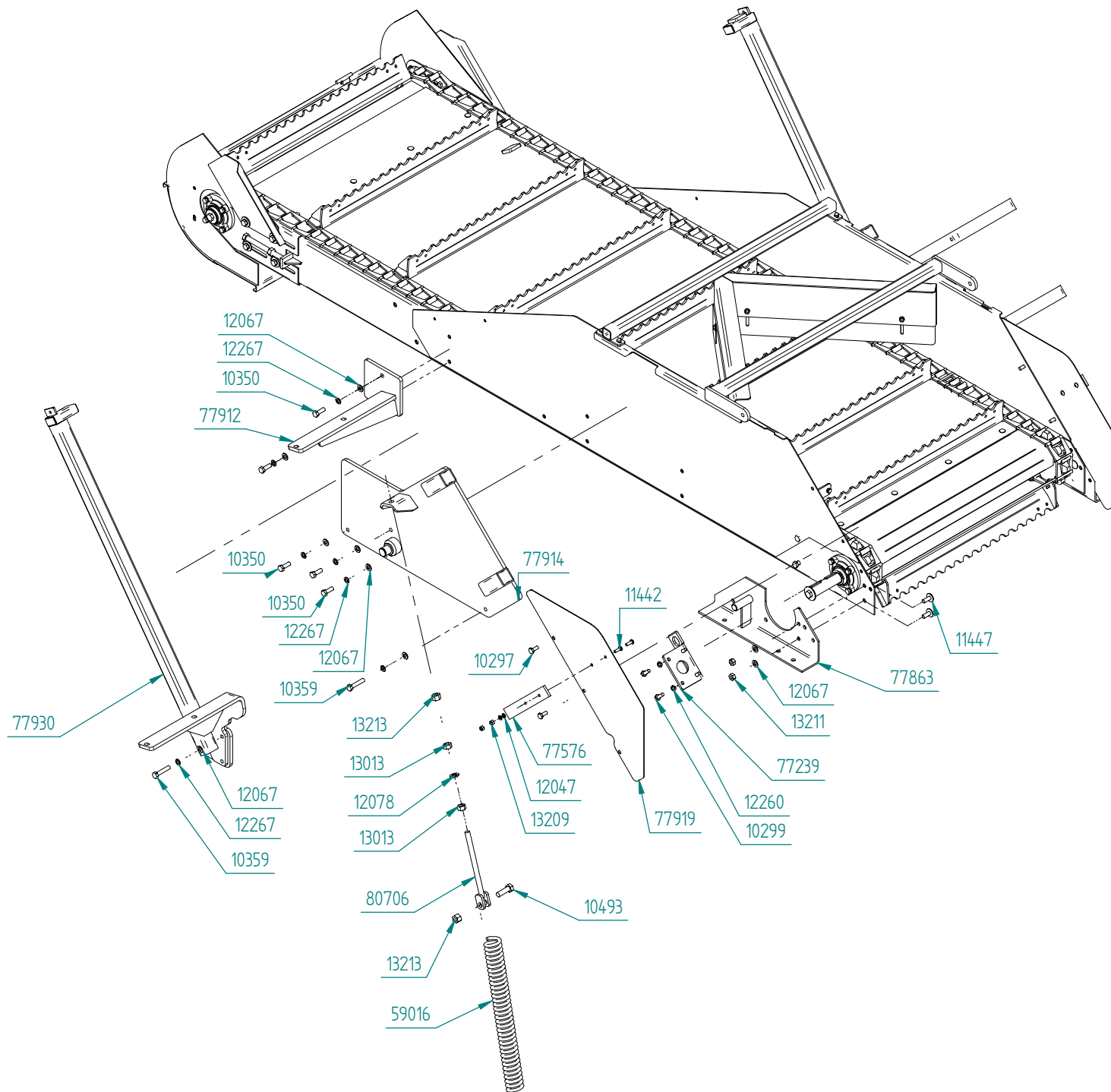

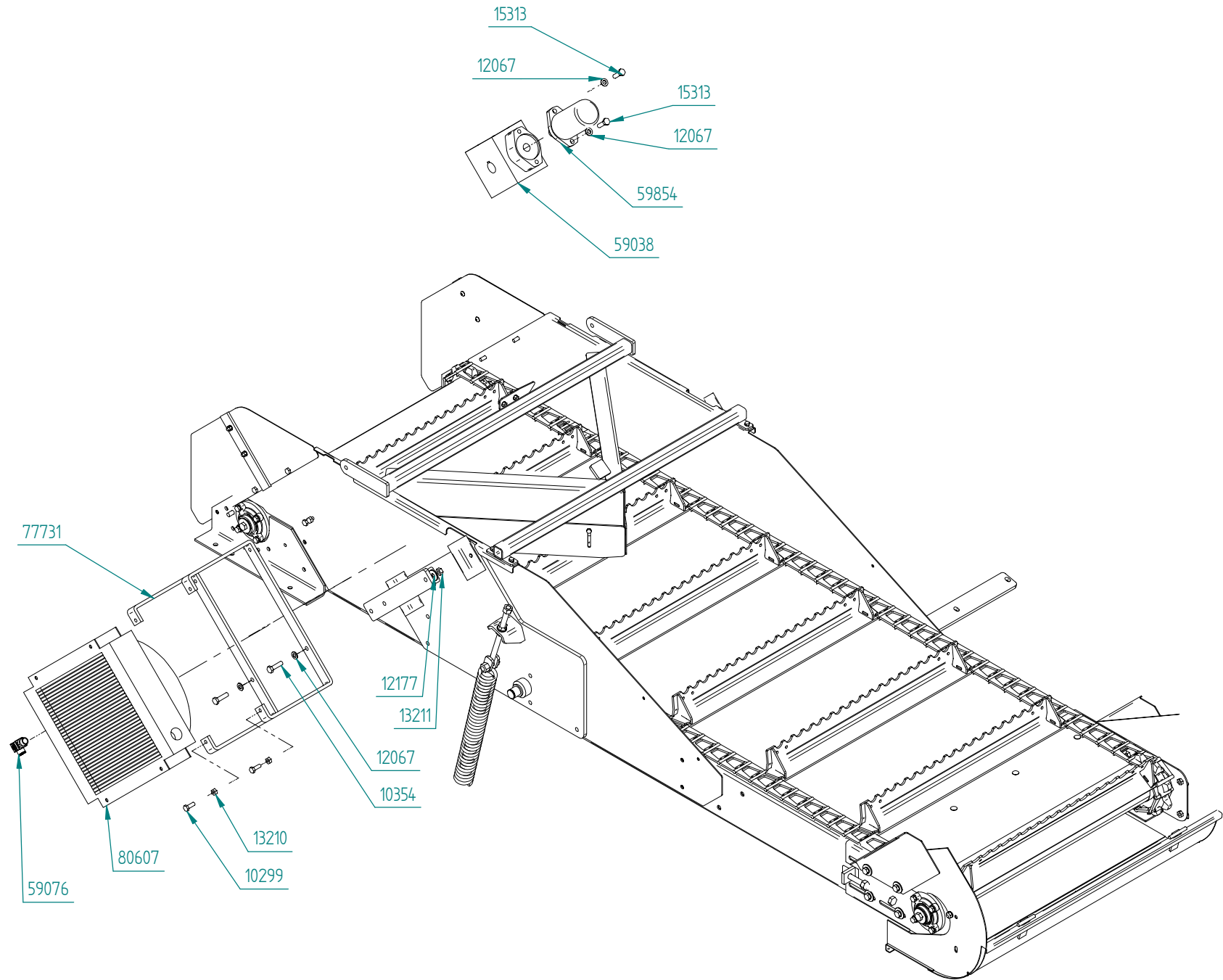

Part Number	Qty.	Title
10244	68	Bolt M8x20
10246	8	Bolt M8x25
10297	4	Bolt M10x25
10299	8	Bolt M10x30
10305	16	Bolt M10x45
10346	7	Bolt M12x25
10348	8	Bolt M12x30
10350	8	Bolt M12x35
10354	4	Bolt M12x45
10359	2	Bolt M12x60
10493	2	Bolt M16x50
11101	4	Lock head bolt M8x40
11116	4	Lock head bolt M8x25
11123	4	Lock head bolt M8x120
11442	4	Lense head bolt M8x25
11447	4	Lense head bolt M12x30
12047	156	Washer M8
12060	18	Washer M10
12067	25	Washer M12
12078	2	Washer M16
12147	8	Washer \varnothing 24/8,4x2
12177	2	Washer \varnothing 35/12,5x3
12178	8	Washer \varnothing 37/13x3
12260	4	Spring washer M10

Part Number	Qty.	Title
12267	25	Spring washer M12
13013	6	Nut M16
13209	88	Lock nut M8
13210	5	Lock nut M10
13211	6	Lock nut M12
13213	4	Lock nut M16
13606	1	Pan bolt M10x25
15215	2	Bolt M16x180, threaded to head
15301	4	Bolt M14x20
15313	2	Bolt M12x40
50015	160	Chain link Kohlswa Ewart 78
50805	2	Key 10x8x50
52507	3	Key 12x8x50
55016	4	Bearing UCFCX08
59016	2	Spring
59038	1	Gear RT 90
59076	1	Thermostat
59081	4	Sprocket
59576	1	Oil cooler SCM A56 1EAX12
59654	2	Rubber buffer 10x50x50
59854	1	Motor BR130 NC25
77239	1	Bracket, motor
77366	34	Carrier lip
77382	2	Winding protection bearing

Part Number	Qty.	Title
77506	2	Plastic guide rail for belt
77576	2	Upper cover, reinforcement sealing plate
77630	4	Washer \varnothing 50/15x3
77731	2	Bow, oil cooler
77807	1	Protection cover
77811	1	Shaft tightening side
77814	1	Visaform bottom plate
77815	1	Driveshaft behind elevator
77823	1	Frame, elevator
77824	1	Winding protection, lower driver shaft, elevator
77825	1	Tightener, left
77826	1	Tightener, right
77862	1	Bracket upper fastener, left
77863	1	Bracket upper fastener, right
77912	1	Staircase fastener, lower
77913	1	Cylinder bracket left
77914	1	Cylinder bracket right
77916	1	Hatch, loss funnel
77917	1	Sealing plate left spillage tray
77918	1	Sealing plate right spillage tray
77919	2	Sealing plate top
77922	1	Side cover left
77923	1	Side cover right
77929	1	Stopper bottom left

Part Number	Qty.	Title
77930	1	Stopper bottom right
77960	1	Plow
77961	2	Adjustment plate, plow
79640	16	Carrier
79641	1	Spillage tray, expanding
80706	2	Tightening rod, springs, belt tightener

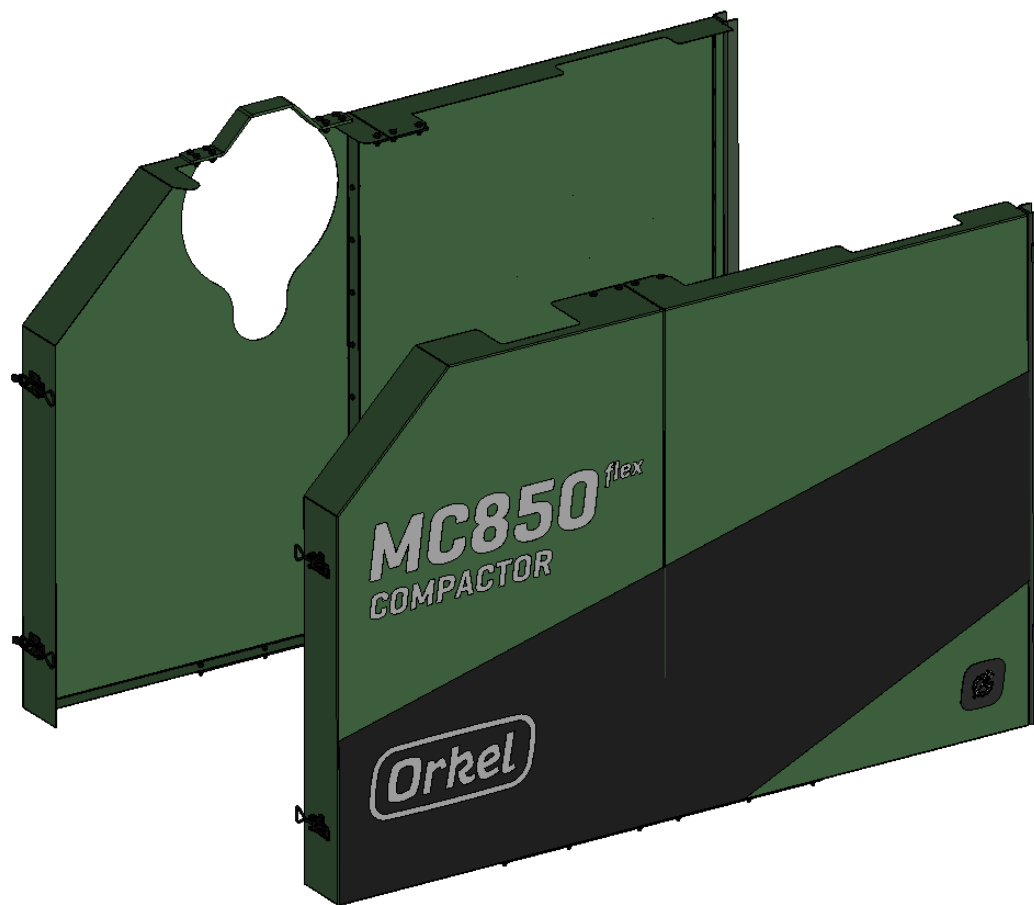

82326

Part number	Qty	Description
16238	2	Sticker, black
16232	2	Sticker, Orkel
16308	2	Sticker MC850 flex
16243	2	Sticker, Gjønnnes

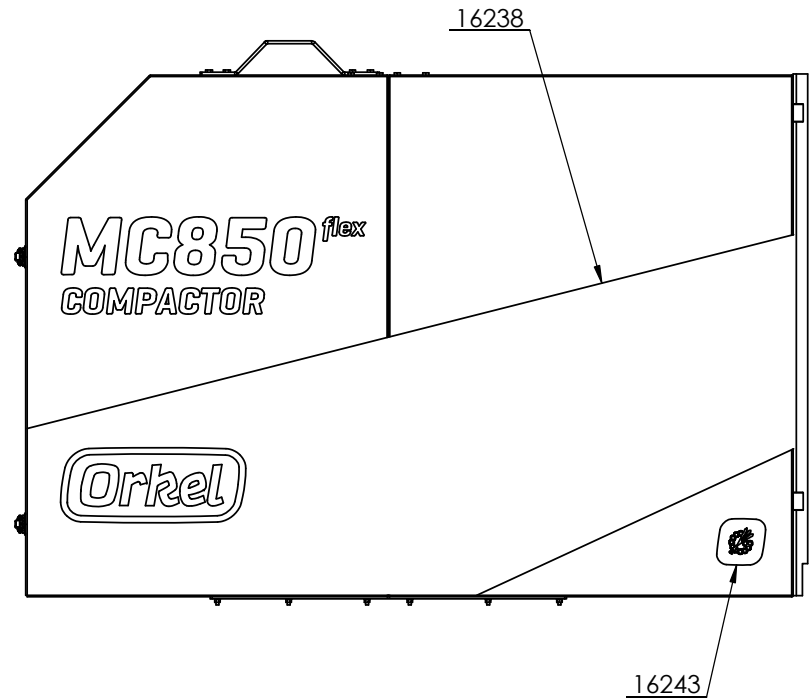
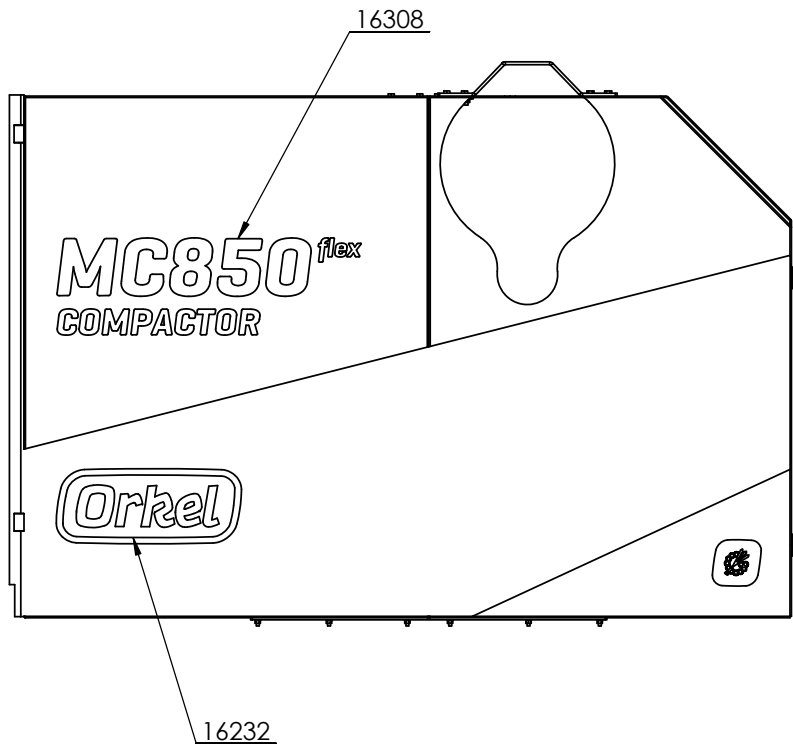

Part number	Qty	Description
77927	1	Hinge channel left side cover
77947	1	Cover left front
77949	1	Cover left rear
77370	2	Stiffener, lower side cover
77372	1	Stiffener, upper side cover left
77996	1	Bow above hydrostatic motor
53043	4	Eccentric lock
10297	35	Bolt M10x25
10244	32	Bolt M8x20
13210	35	Lock nut M10
12047	44	Washer M8
13209	44	Lock nut M8
12060	15	Washer M10
10246	12	Bolt M8x25

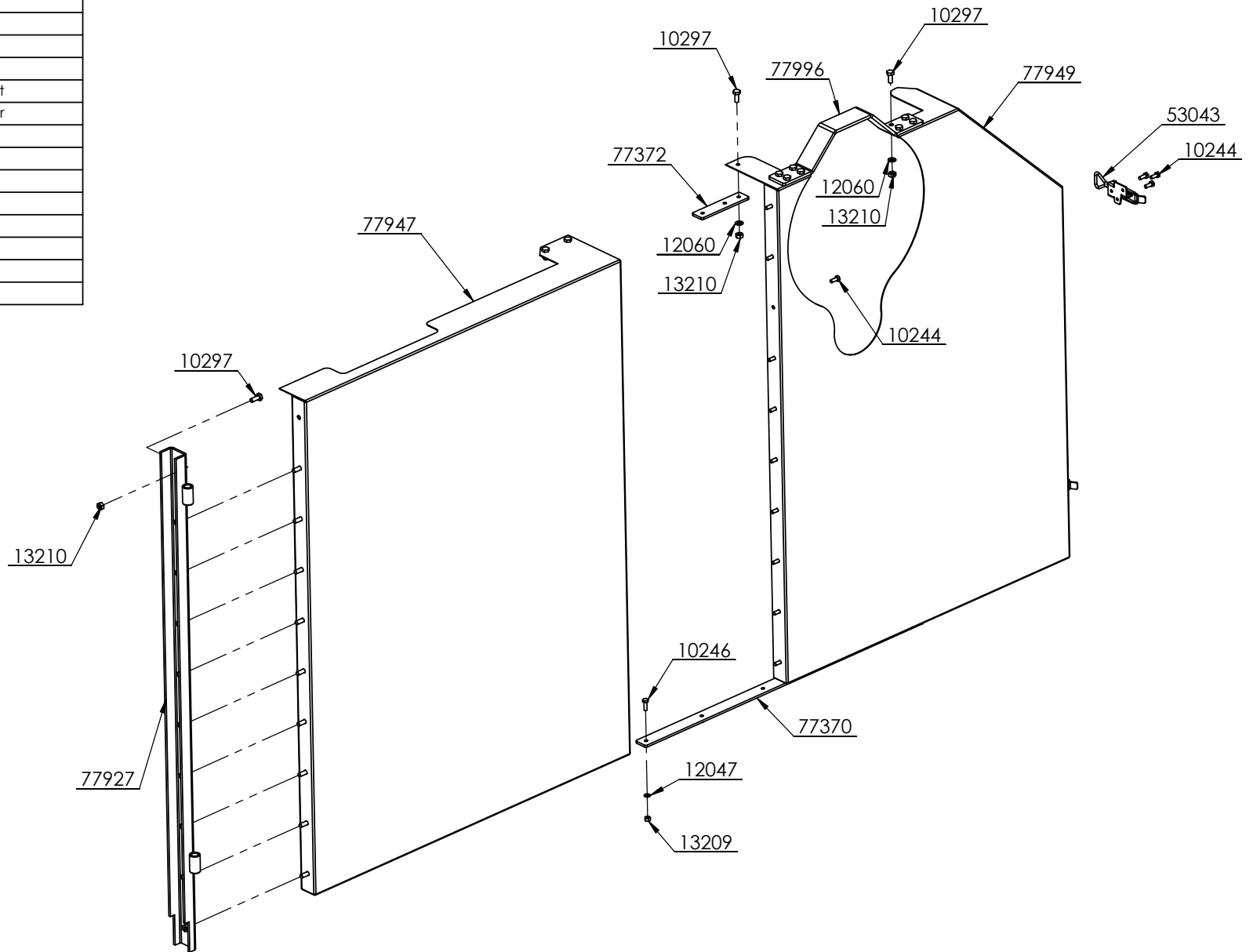

Part number	Qty	Description
77928	1	Hinge channel right side cover
77948	1	Cover right front
77950	1	Cover right rear
77370	2	Stiffener, lower side cover
77371	1	Stiffener, upper side cover right
53043	4	Eccentric lock
10297	35	Bolt M10x25
10244	32	Bolt M8x20
13210	35	Lock nut M10
12047	44	Washer M8
13209	44	Lock nut M8
12060	15	Washer M10
10246	12	Bolt M8x25

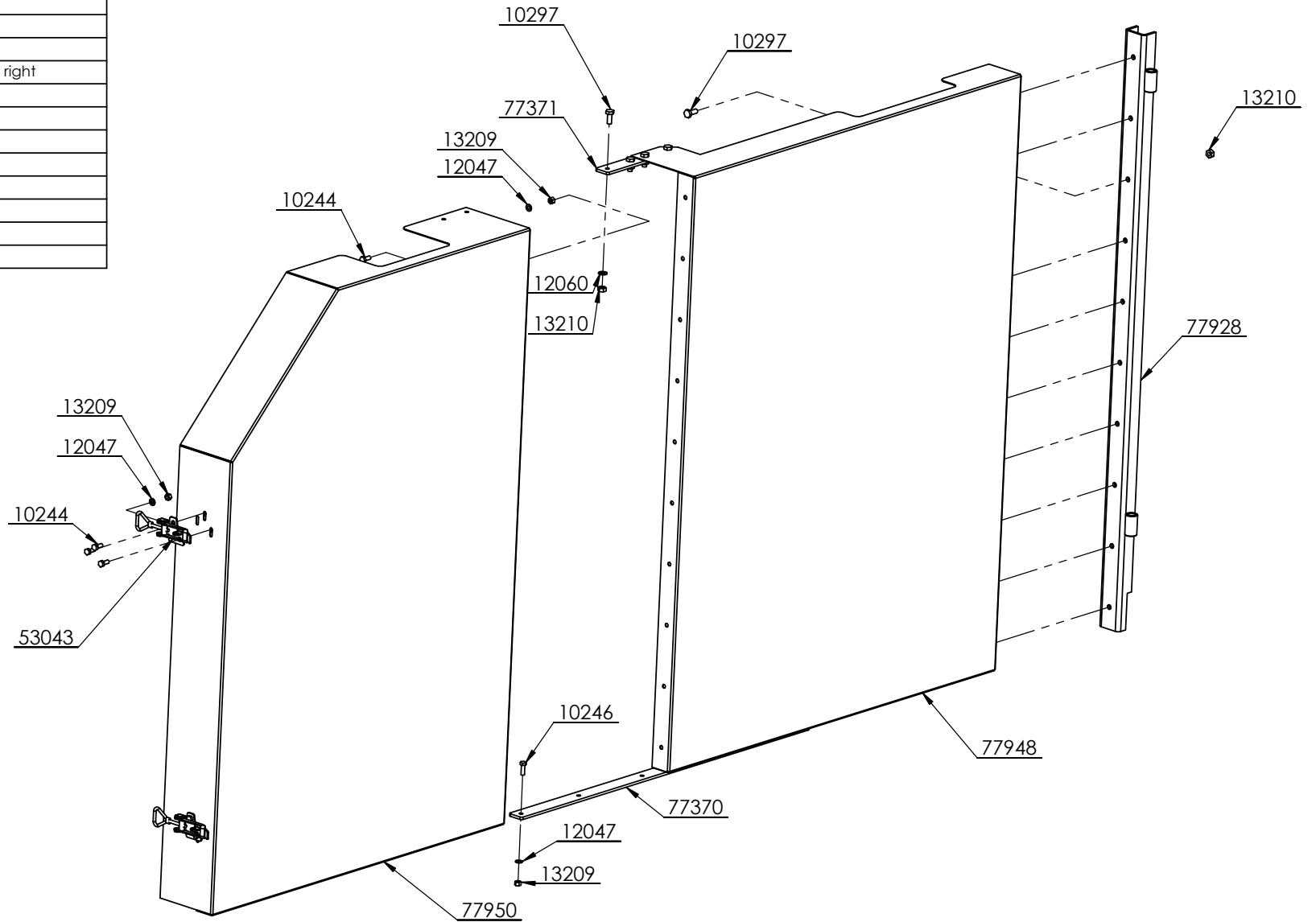

Part number	Qty	Description
10246	16	Bolt M8x25
12047	24	Washer M8
13209	12	Lock nut M8
77564	1	Netting suspension hook
77594	1	Locking net left
77632	1	Hose holder, hydrostat
77881	1	Spillage cover, left, MC
77882	1	Spillage cover, right, MC
77938	1	Cover left below elevator
77939	1	Cover right below elevator
77952	1	Netting, left, MC
77953	1	Netting, right, MC

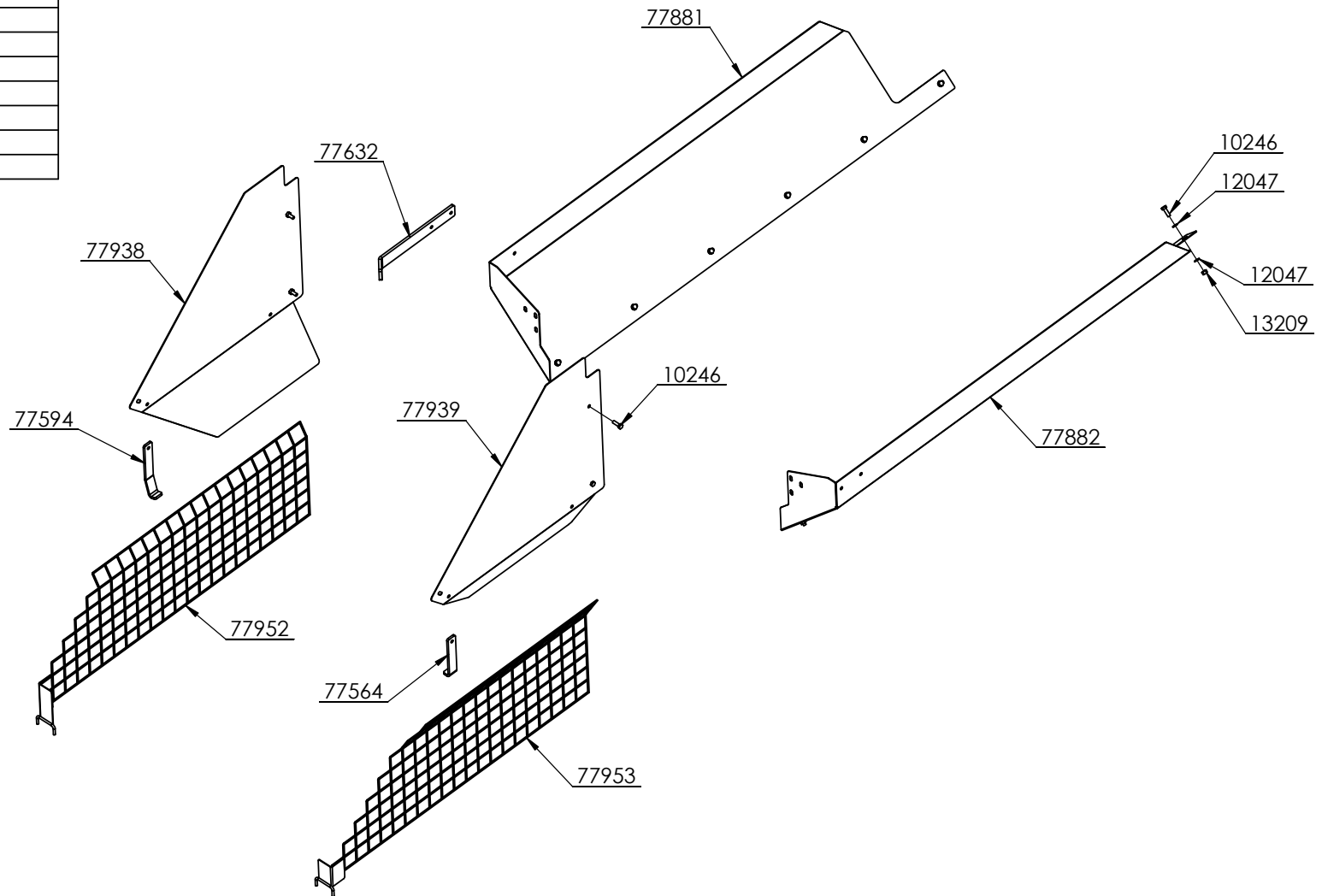

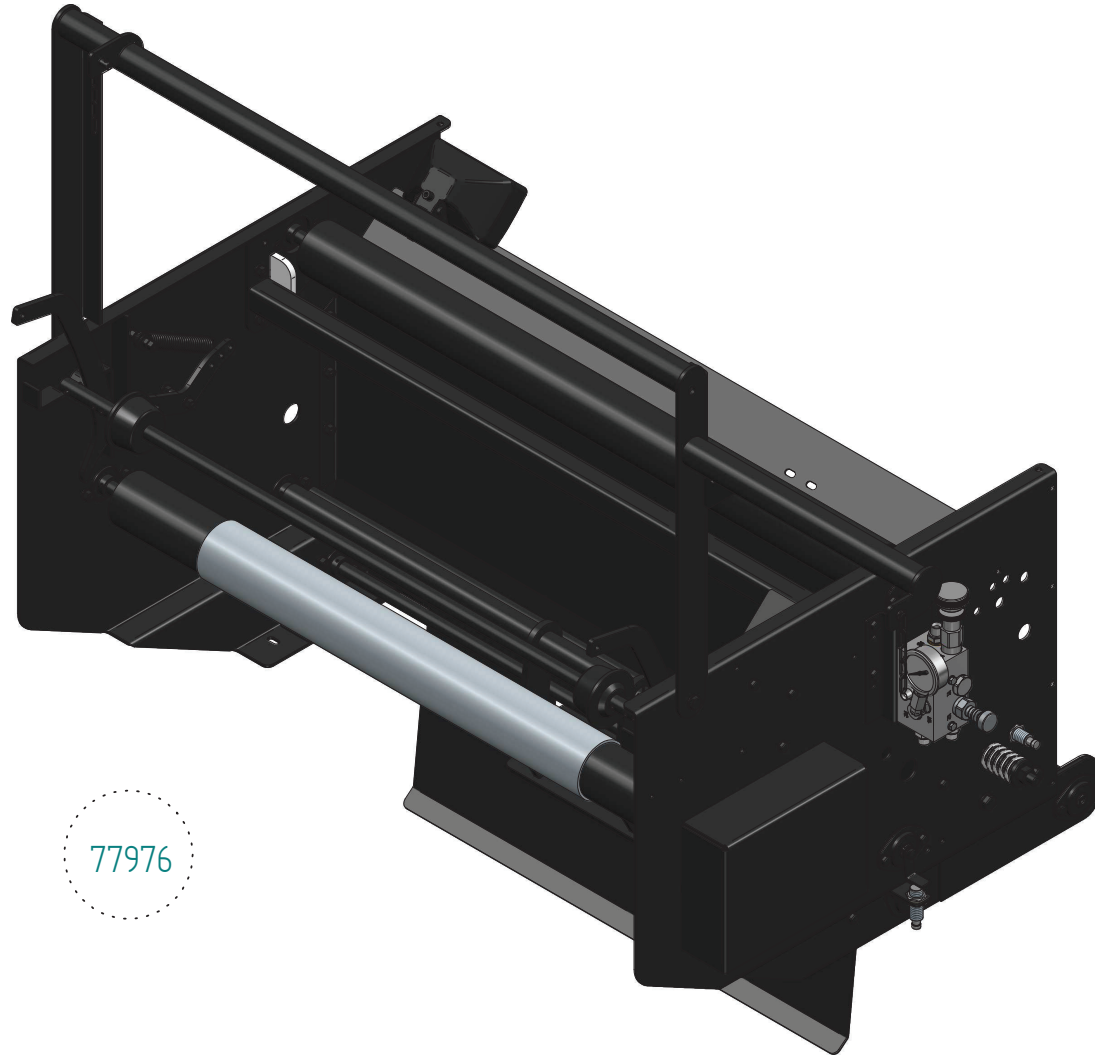

77976

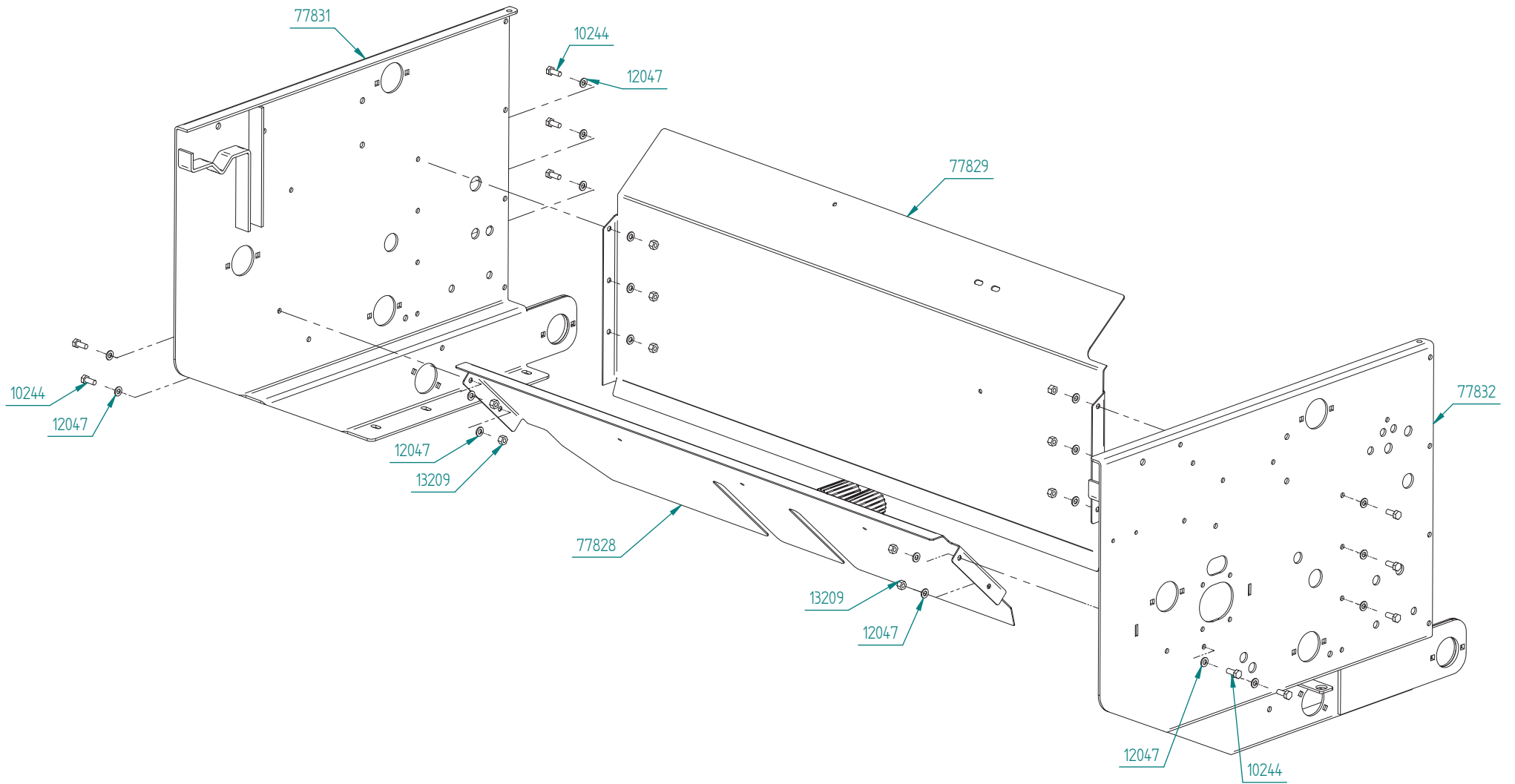

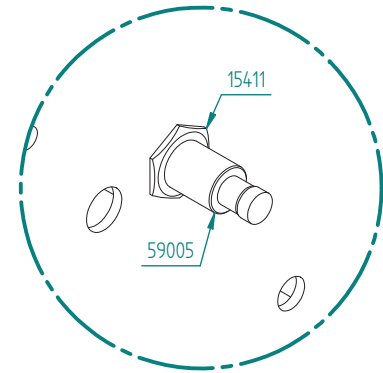
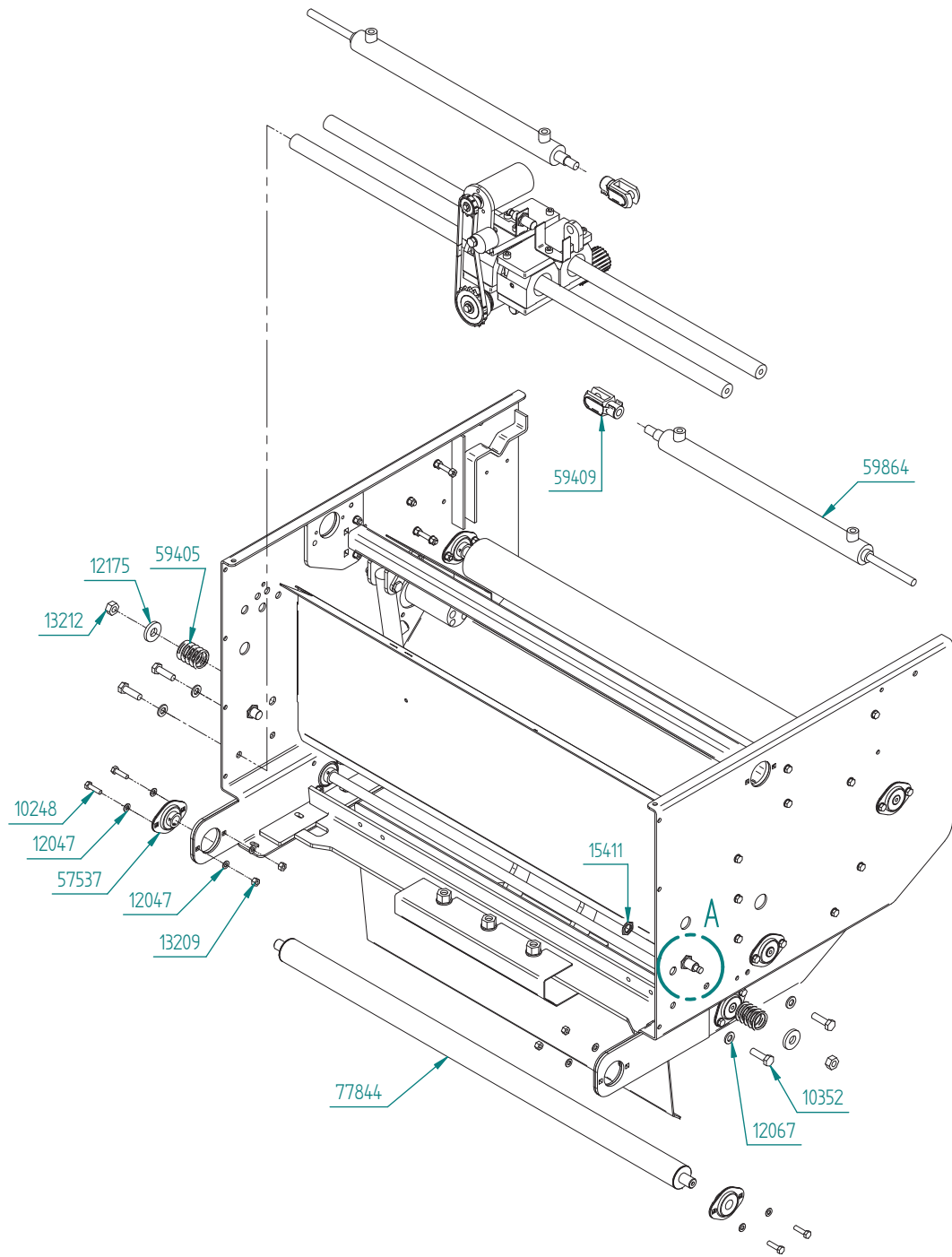

DETAIL A

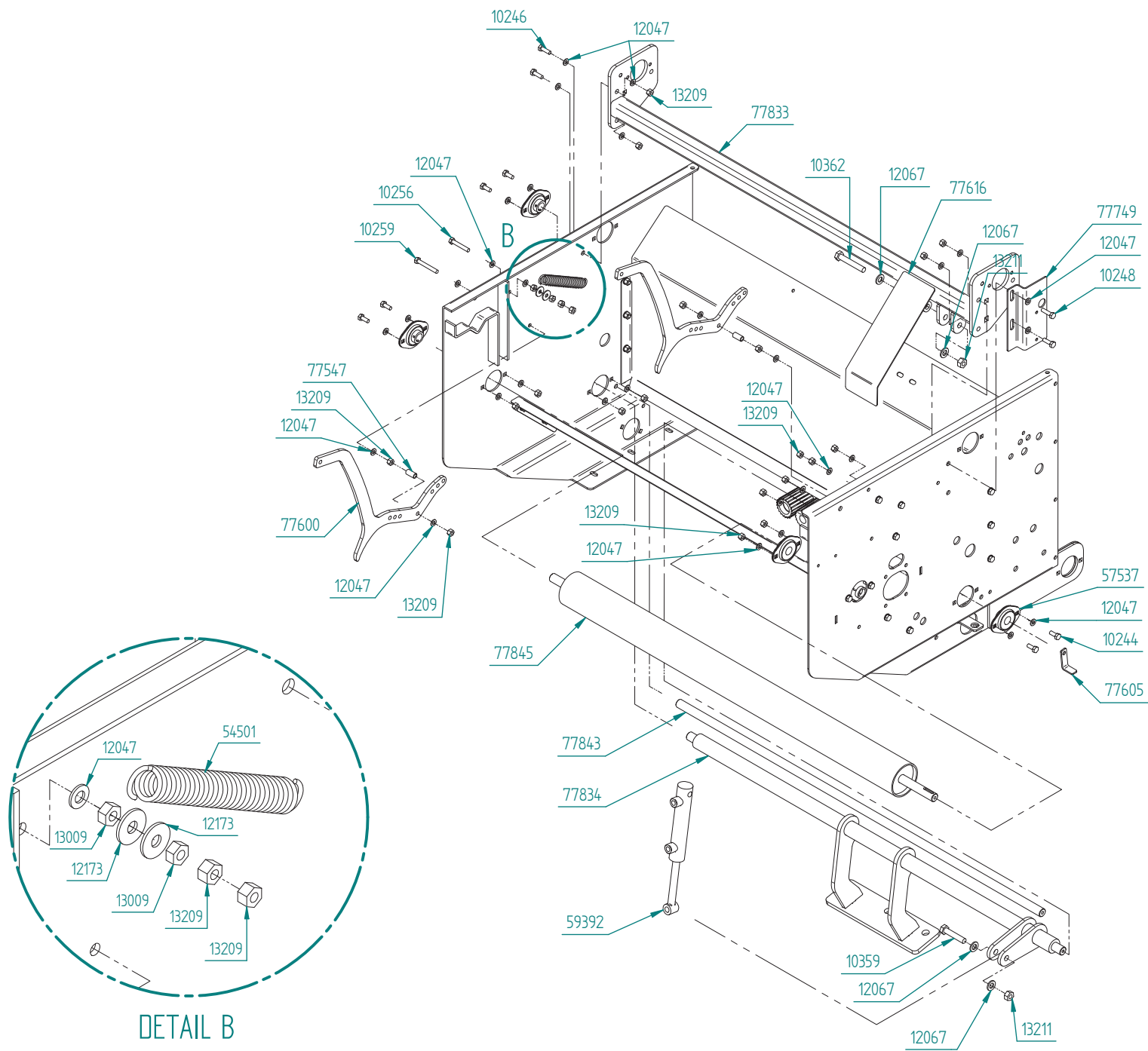

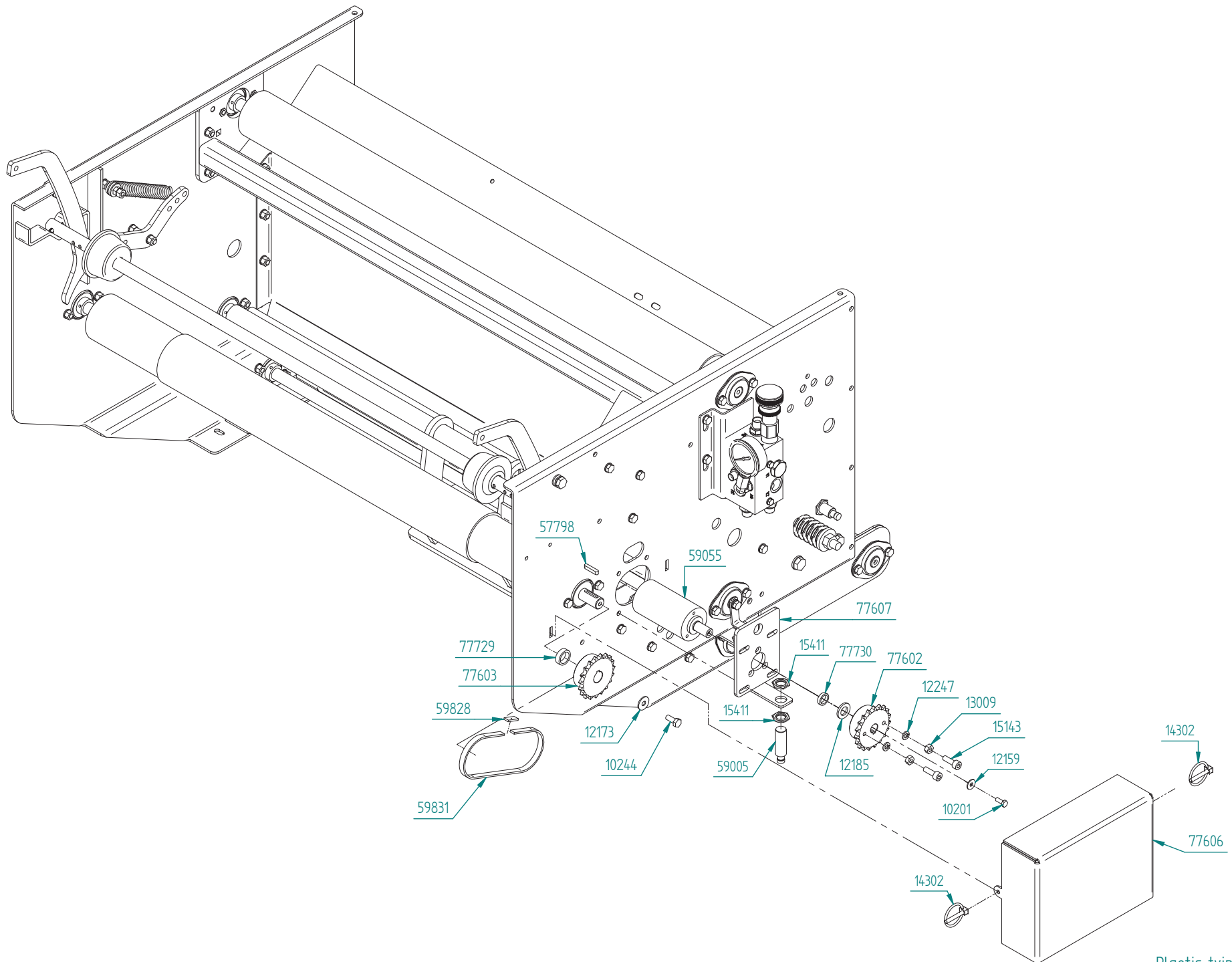

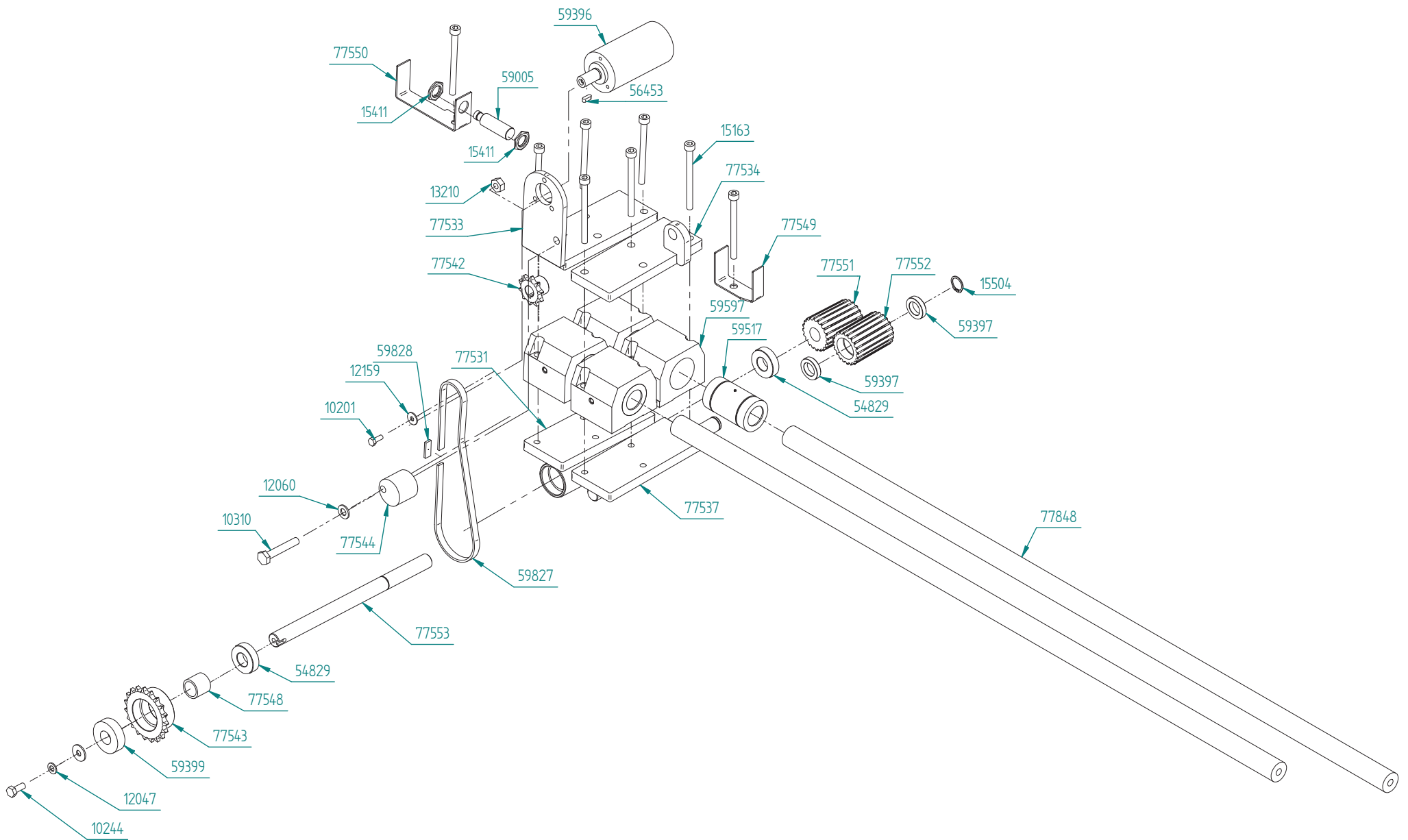

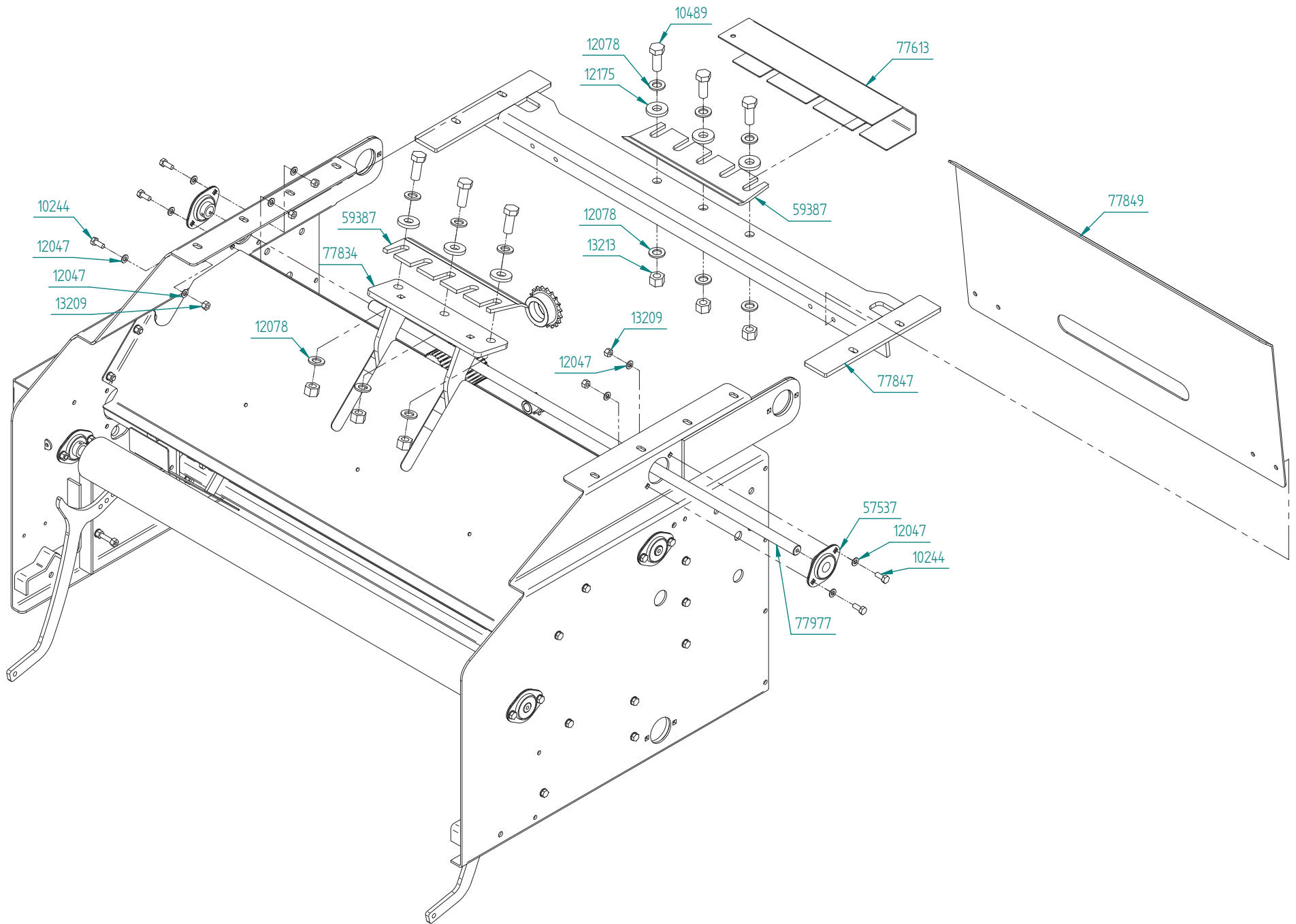

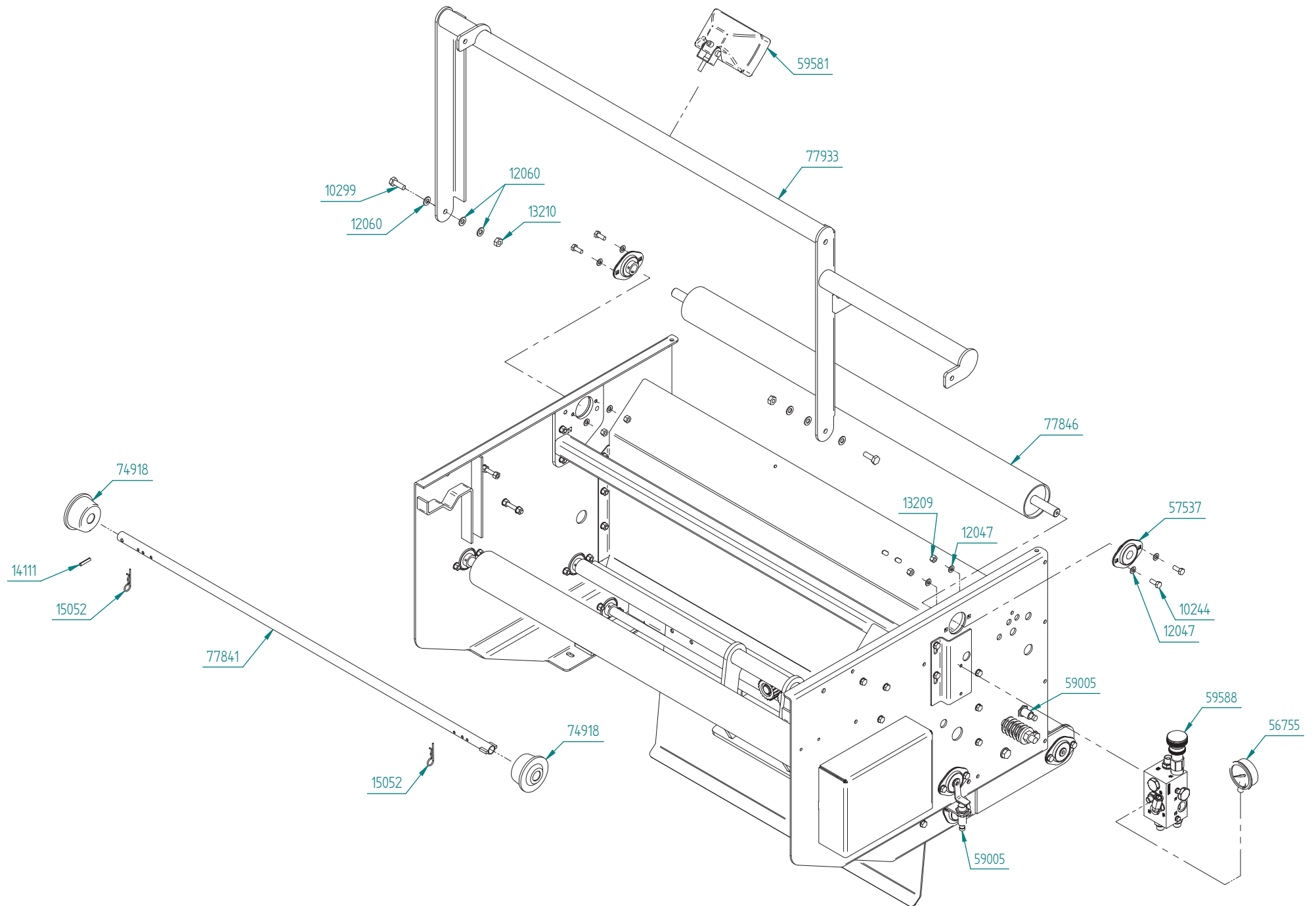

Part Number	Qty.	Title
10201	2	Bolt M6x16, threaded to head
10244	31	Bolt M8x20
10246	3	Bolt M8x25
10248	5	Bolt M8x30
10256	2	Bolt M8x50
10259	2	Bolt M8x60
10299	2	Bolt M10x30
10310	1	Bolt M10x60
10352	4	Bolt M12x40
10359	1	Bolt M12x60
10362	1	Bolt M12x75
10489	6	Bolt M16x40, threaded to head
12047	84	Washer M8
12060	7	Washer M10
12067	8	Washer M12
12078	12	Washer M16
12159	2	Washer \varnothing 18/6,4
12173	6	Washer \varnothing 24/8,4x2
12175	8	Washer \varnothing 40/17x6
12185	1	Washer \varnothing 28/16x3
12247	3	Spring washer M8
13009	6	Nut M8
13209	44	Lock nut M8
13210	3	Lock nut M10

Part Number	Qty.	Title
13211	2	Lock nut M12
13212	2	Lock nut M14
13213	6	Lock nut M16
14111	1	Splint \varnothing 6x30
14302	2	Ear pin M6
15052	2	Hairpin M2,5
15143	2	Bolt M8x25, cylinderhead
15163	8	Bolt M8x100, cylinderhead
15411	10	Lock nut M18
15504	3	Circlip A20x1,2
54501	2	Spring \varnothing 23/ \varnothing 17x120
54829	2	Bearing 6004 2RS
56453	1	Key 5x5x15
56755	1	Manometer
57537	10	Bearing SBPFL204
57798	1	Key 6x6x30
59005	5	Inductive transducer
59055	1	Motor BGM32 C16SP
59387	2	Knife
59390	4	Bearing housing w/bearing, linear
59392	1	Cylinder 35x15x190
59396	1	Motor BGM50 C16SP
59397	2	Bearing 6804 2RS
59399	1	Bearing ZZ 6204 P, one-way

Part Number	Qty.	Title
59405	2	Spring
59409	2	Fork head
59581	1	Flood light
59588	1	Block for feeding and brake
59827	1	Chain 1/2"
59828	2	Chain lock 1/2"
59831	1	Chain 1/2"
59864	2	Cylinder 32x20x445
74918	2	Plastic cone
77531	1	Bracket for bearings, driveshaft
77533	1	Cylinder fastener, driveshaft
77534	1	Cylinder fastener, impeller
77537	1	Bracket for bearings, impeller
77542	1	Sprocket 08B z10
77543	1	Sprocket 08B z19
77544	1	Chain tightener
77547	2	Spacer, tightener
77548	1	Spacer, driveshaft
77549	1	Sensor bracket 1
77550	1	Sensor bracket 2
77551	1	Driveshaft feeding sprocket
77552	1	Impeller, feeding
77553	1	Driveshaft
77600	2	Net roll tightener

Part Number	Qty.	Title
77602	1	Sprocket
77603	1	Sprocket
77605	1	Signalplate for sensor, knife
77606	1	Chain cover, brake roller
77607	1	Bracket, brake motor
77613	1	Cover, behind plastic knife
77616	1	Cover, brake motor
77729	1	Spacer
77730	2	Seamless tube $\varnothing 21,3 \times 3,2$
77749	1	Bracket valve, brake
77828	1	Middle plate, rear
77829	1	Middle plate, front
77831	1	Left side wall
77832	1	Right side wall
77833	1	Stange
77834	1	Knife shaft
77841	1	Tube for plastic roller
77843	1	Guiding roller 2, plastic
77844	1	Guide roller, front
77845	1	Brake roller
77846	1	Guide roller, upper
77847	1	Bottom frame
77848	2	Shaft, linear bearing
77849	1	Middle plate under

Part Number	Qty.	Title
77933	1	Handrail
77977	1	Plastic guide

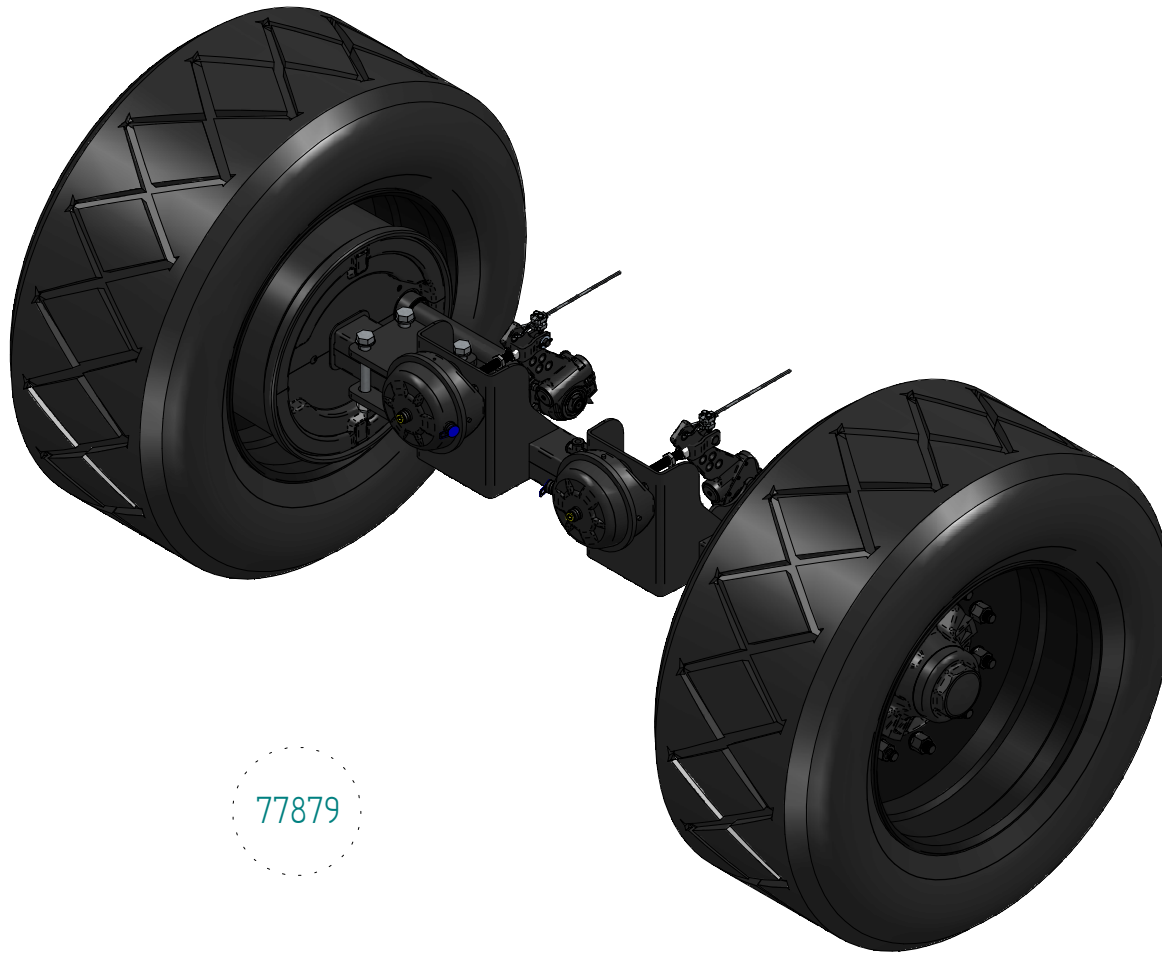

77879

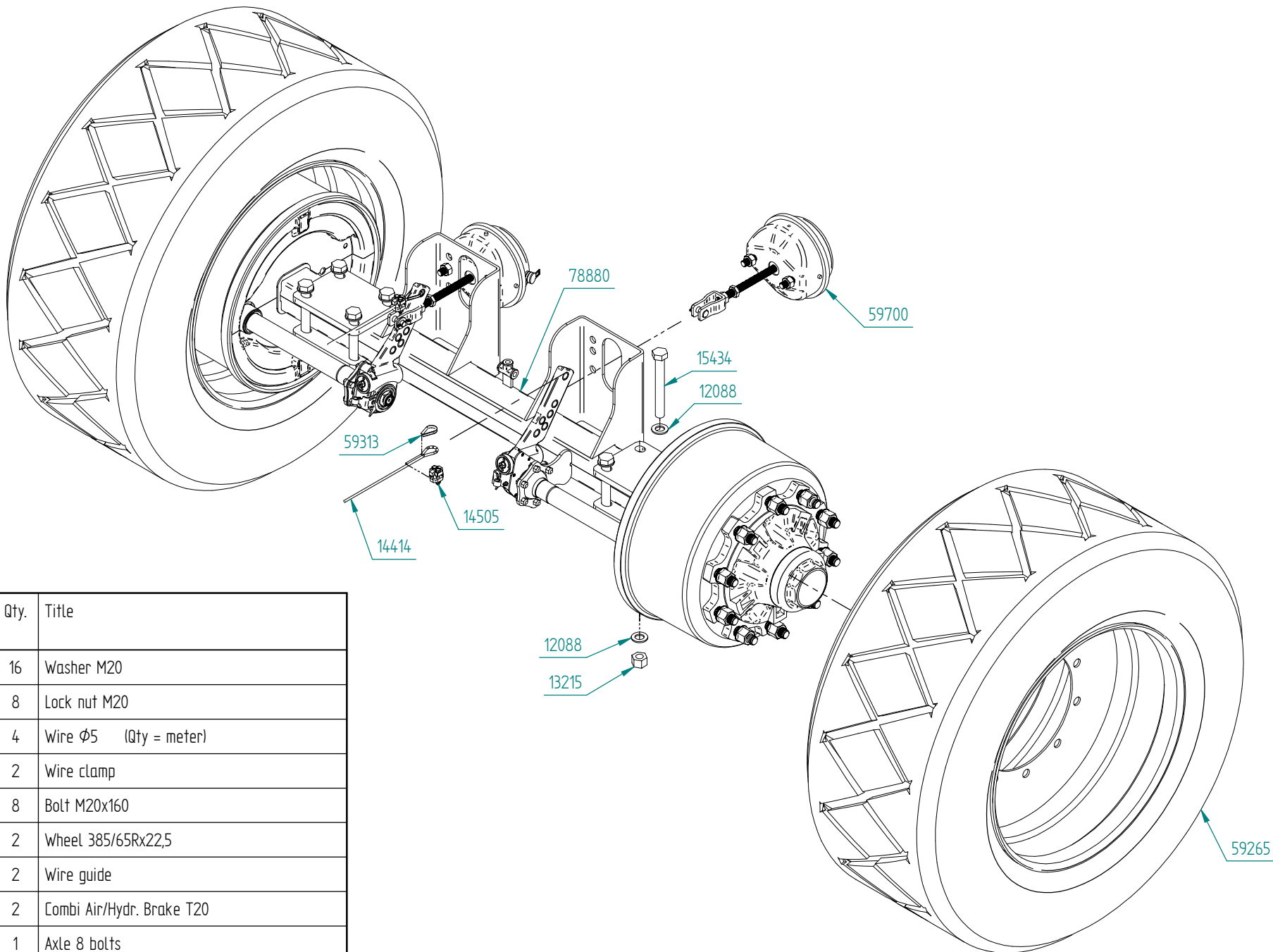

Part Number	Qty.	Title
12088	16	Washer M20
13215	8	Lock nut M20
14414	4	Wire $\phi 5$ (Qty = meter)
14505	2	Wire clamp
15434	8	Bolt M20x160
59265	2	Wheel 385/65Rx22,5
59313	2	Wire guide
59700	2	Combi Air/Hydr. Brake T20
78880	1	Axle 8 bolts



78000



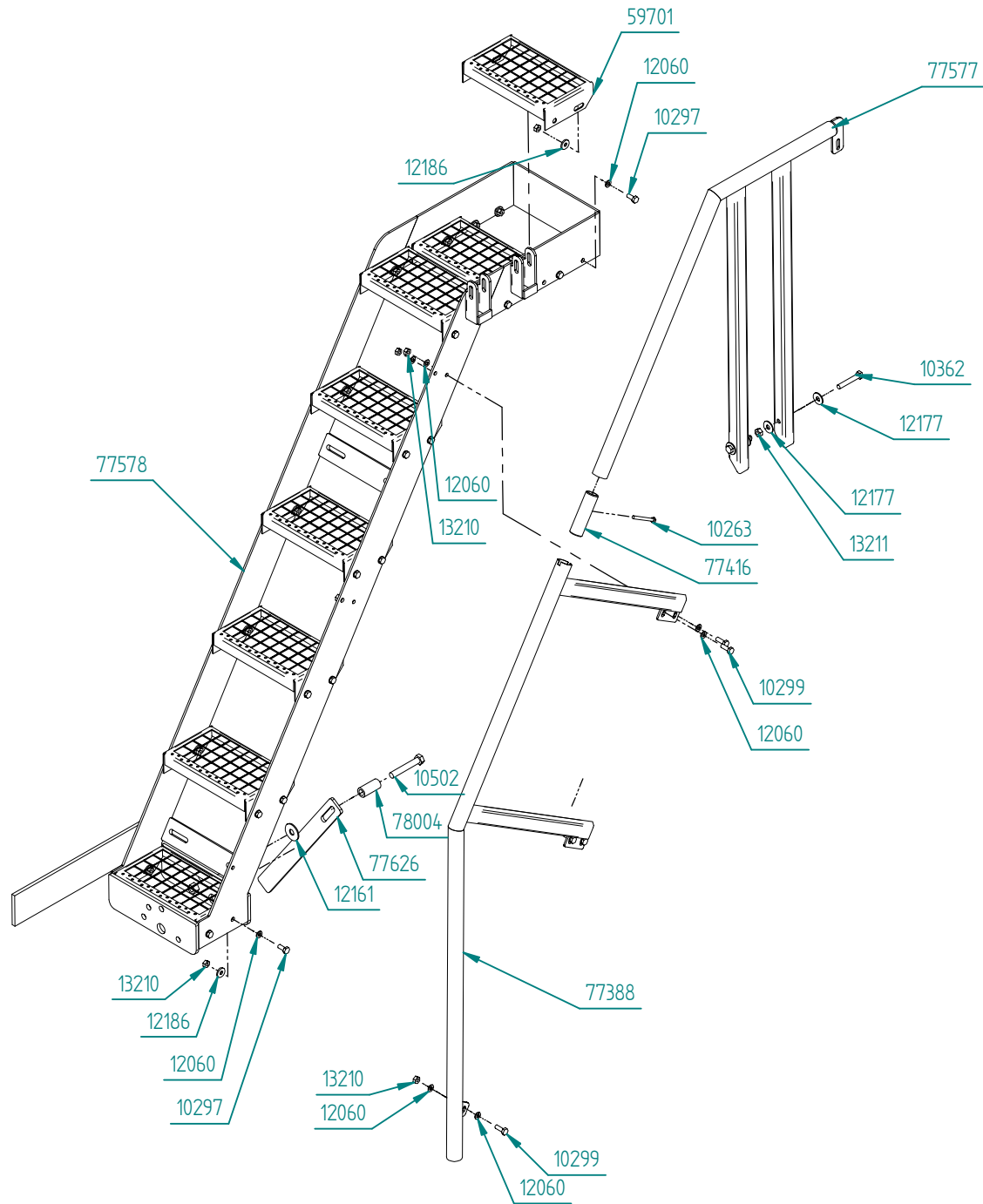

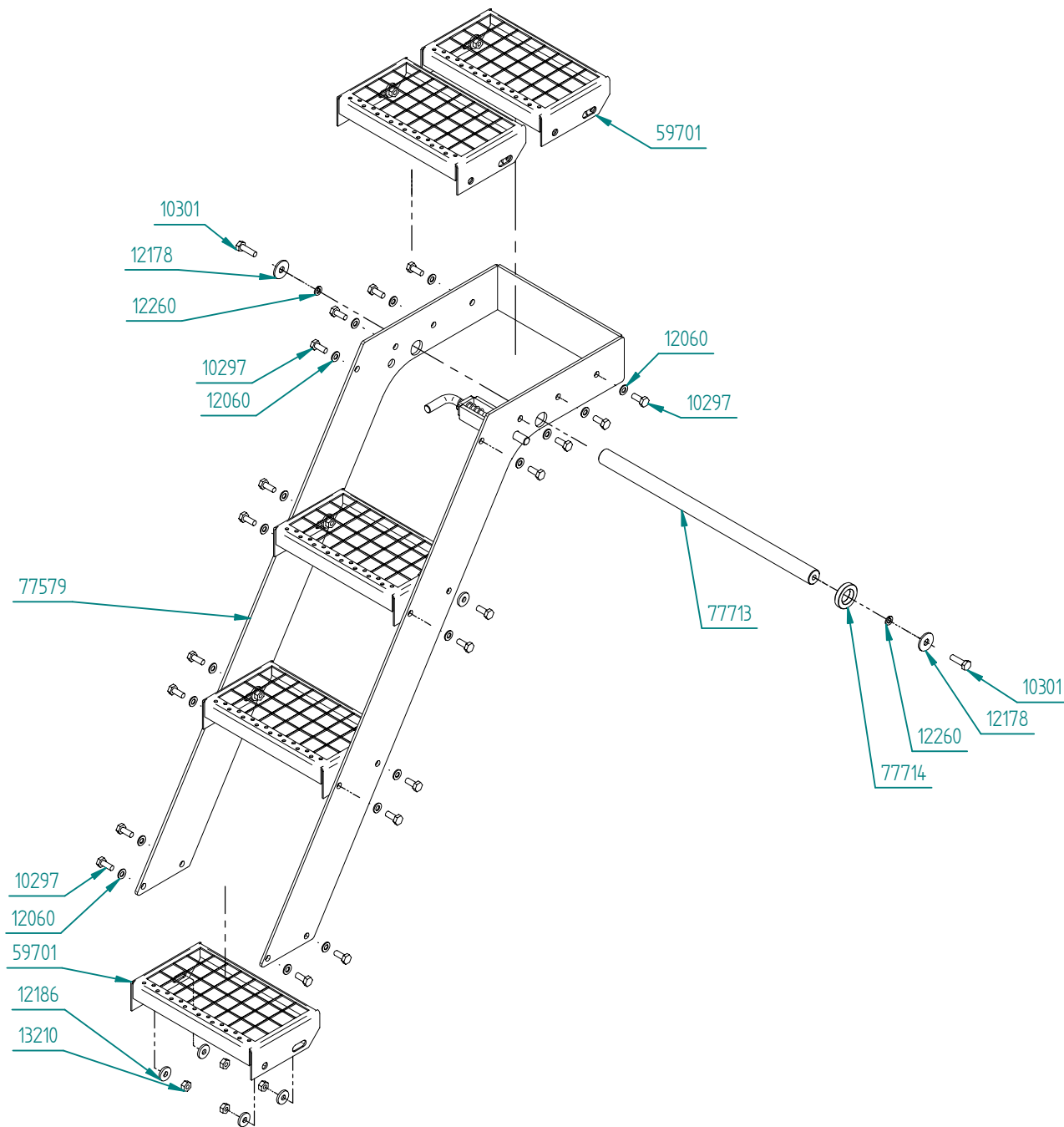

Part Number	Qty.	Title
10263	1	Bolt M8x85
10297	52	Bolt M10x25
10299	5	Bolt M10x30
10301	2	Bolt M10x35, threaded to head
10362	2	Bolt M12x75
10502	1	Bolt M16x100
12060	62	Washer M10
12161	1	Washer \varnothing 50/17x3
12177	4	Washer \varnothing 35/12,5x3
12178	2	Washer \varnothing 37/13x3
12186	52	Washer \varnothing 30/11x2,5
12260	2	Spring washer M10
13210	57	Lock nut M10
13211	2	Lock nut M12
13213	1	Lock nut M16
59701	13	Step
77388	1	Handrails, lower
77416	1	Railing spacer
77577	1	Upper handrails, repos
77578	1	Upper staircase railing
77579	1	Lower staircase
77626	1	Support for staircase
77713	1	Shaft, lower staircase
77714	1	Spacer
78004	1	Spacer M16

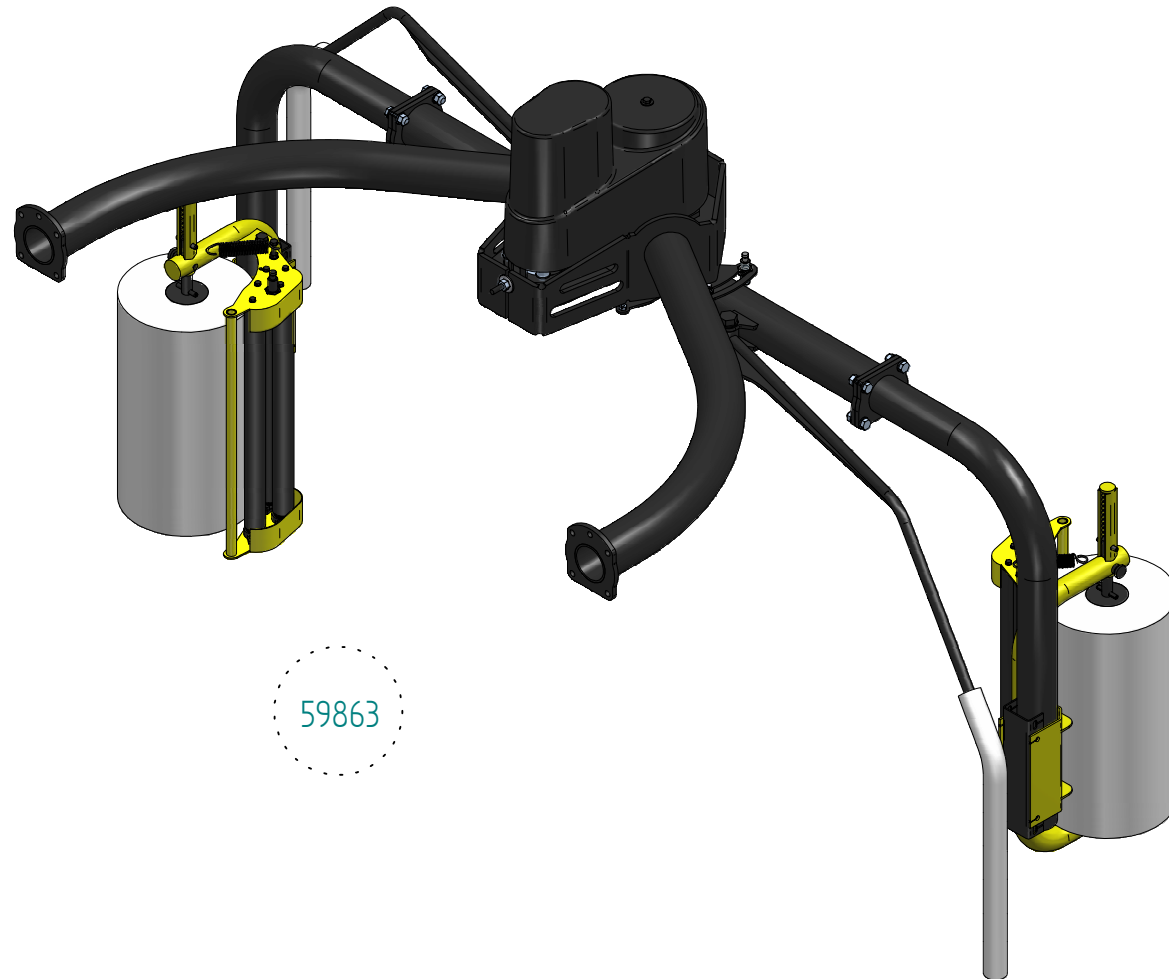

59863

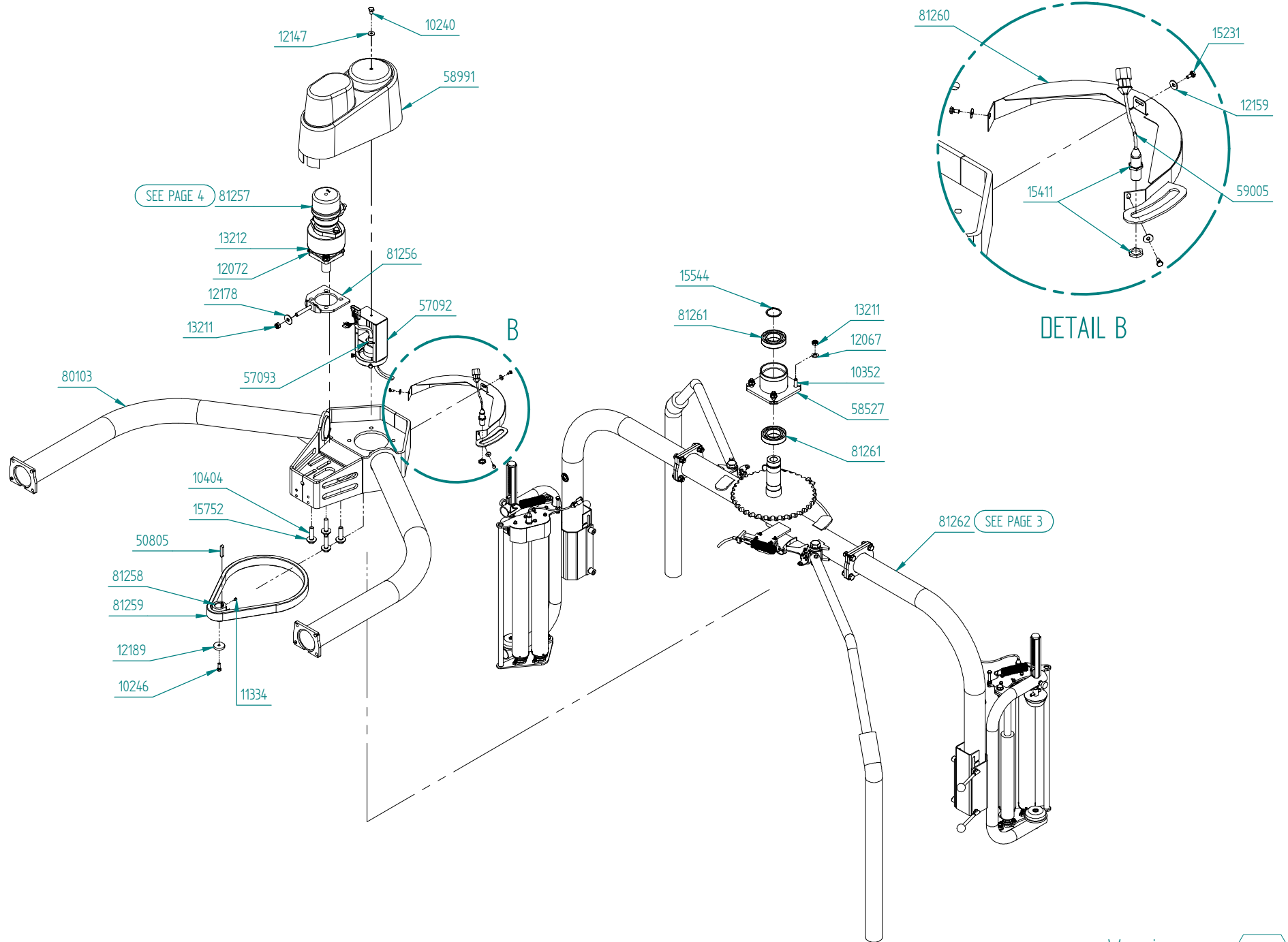

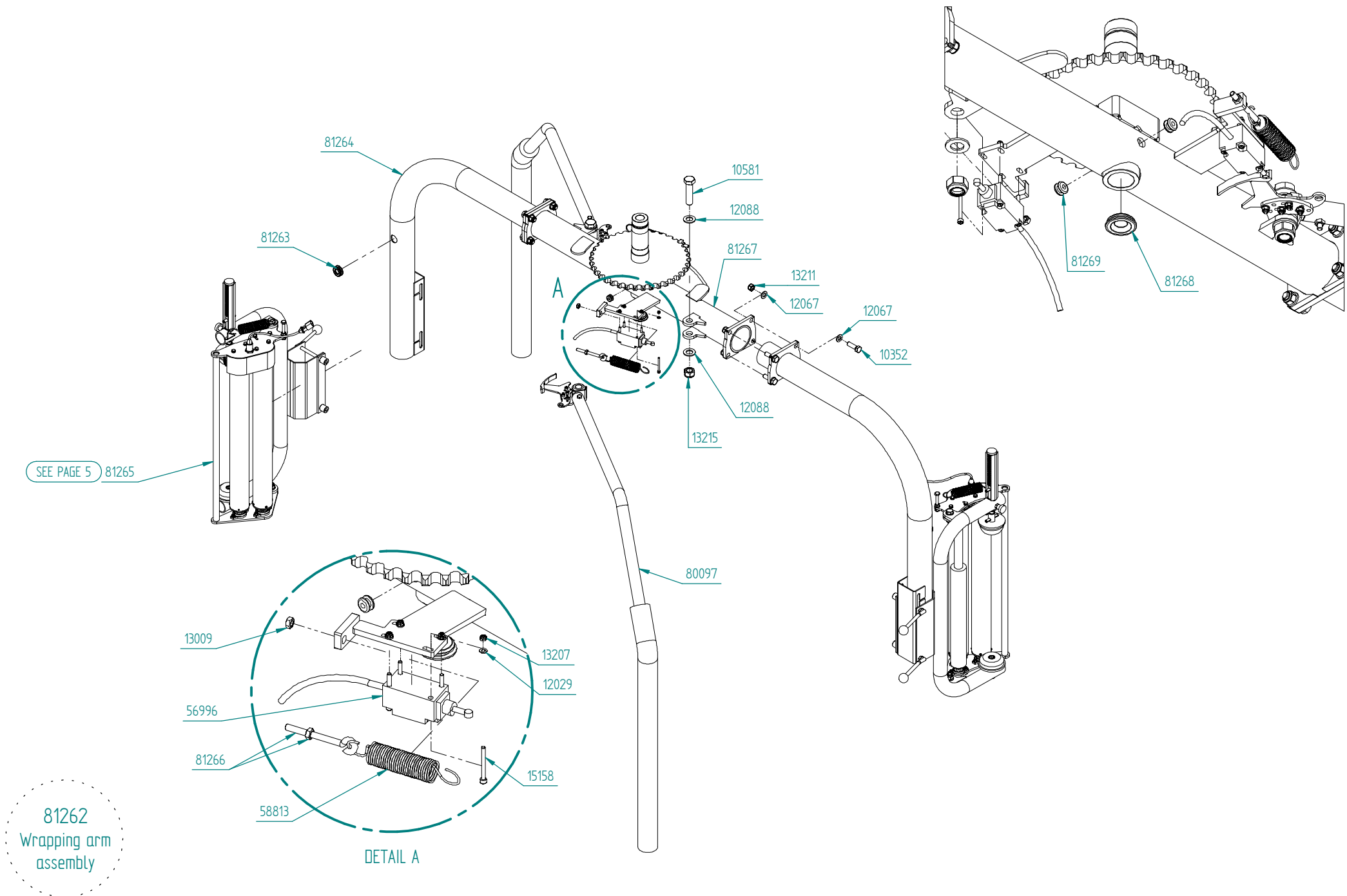

81262
Wrapping arm
assembly

Mounted on frame
81078 Valve block assembly, with 12V coil

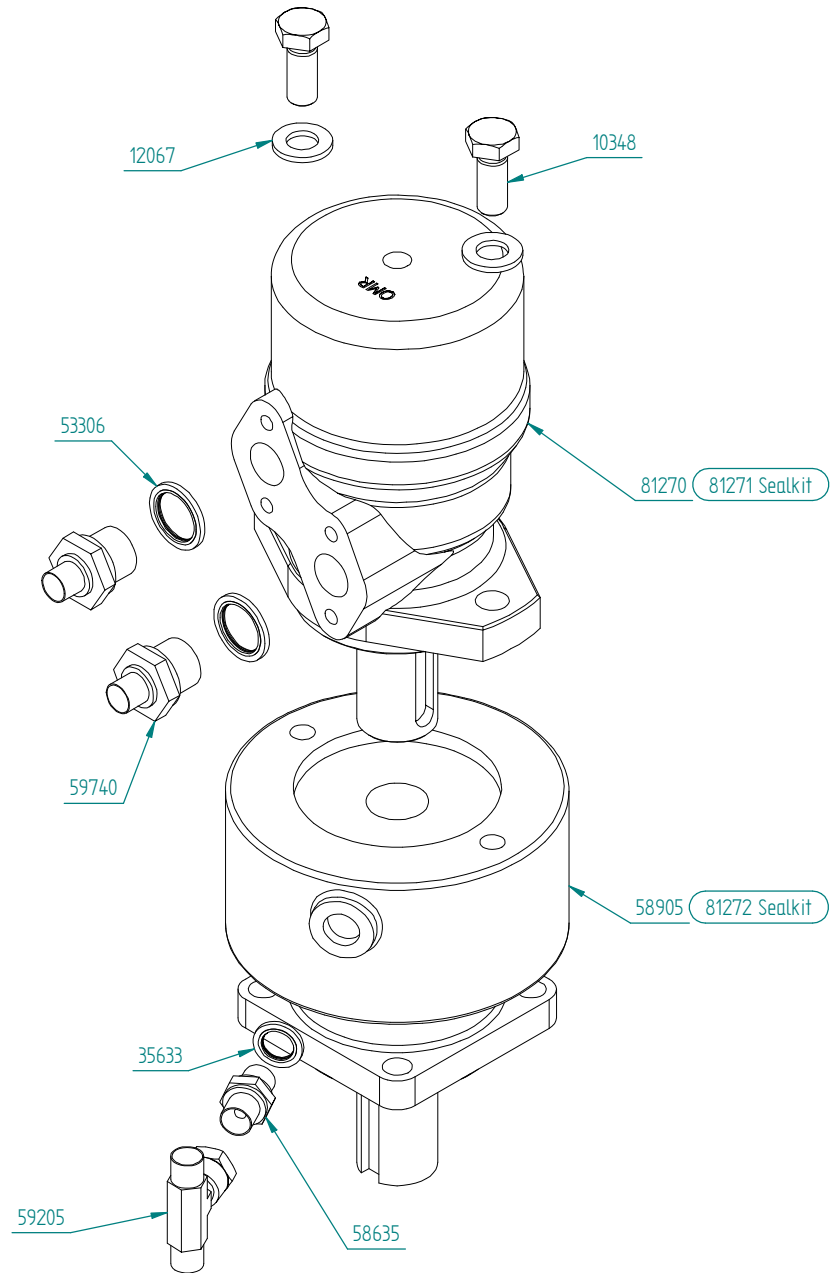
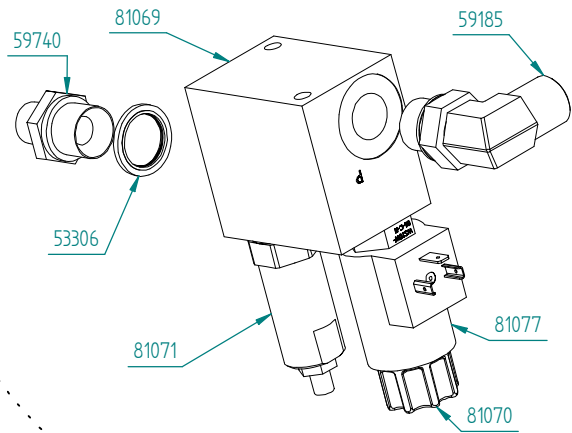

81257
Wrapping motor
assembly

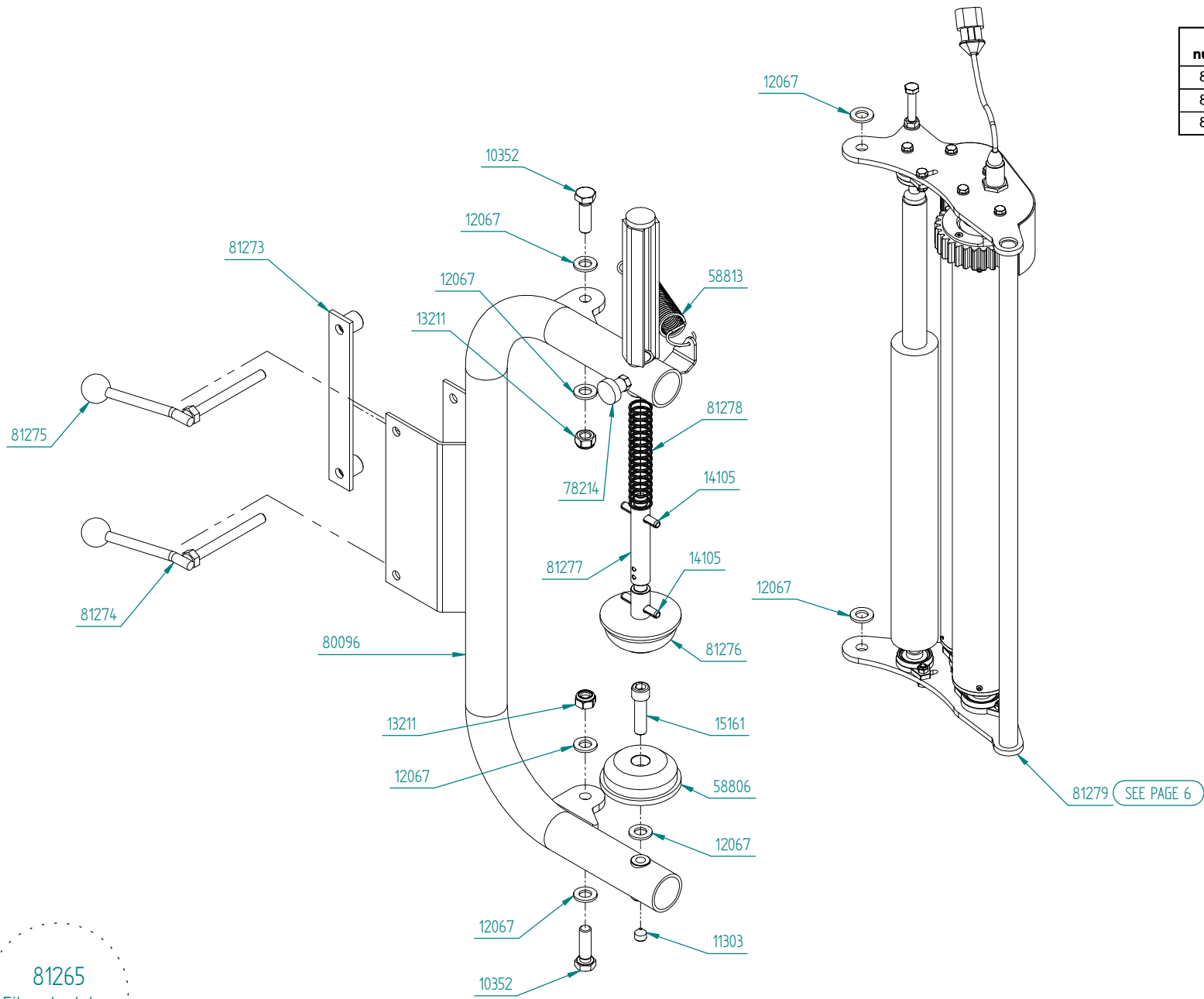

81265
Film stretcher

Part number	Qty	Description
82677	2	Adapter tube 300
82678	2	Adapter tube 350
82679	2	Adapter tube 250

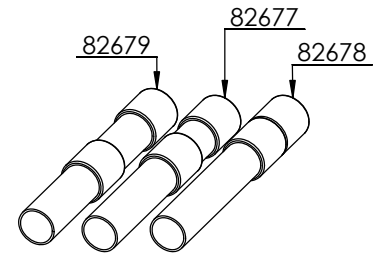

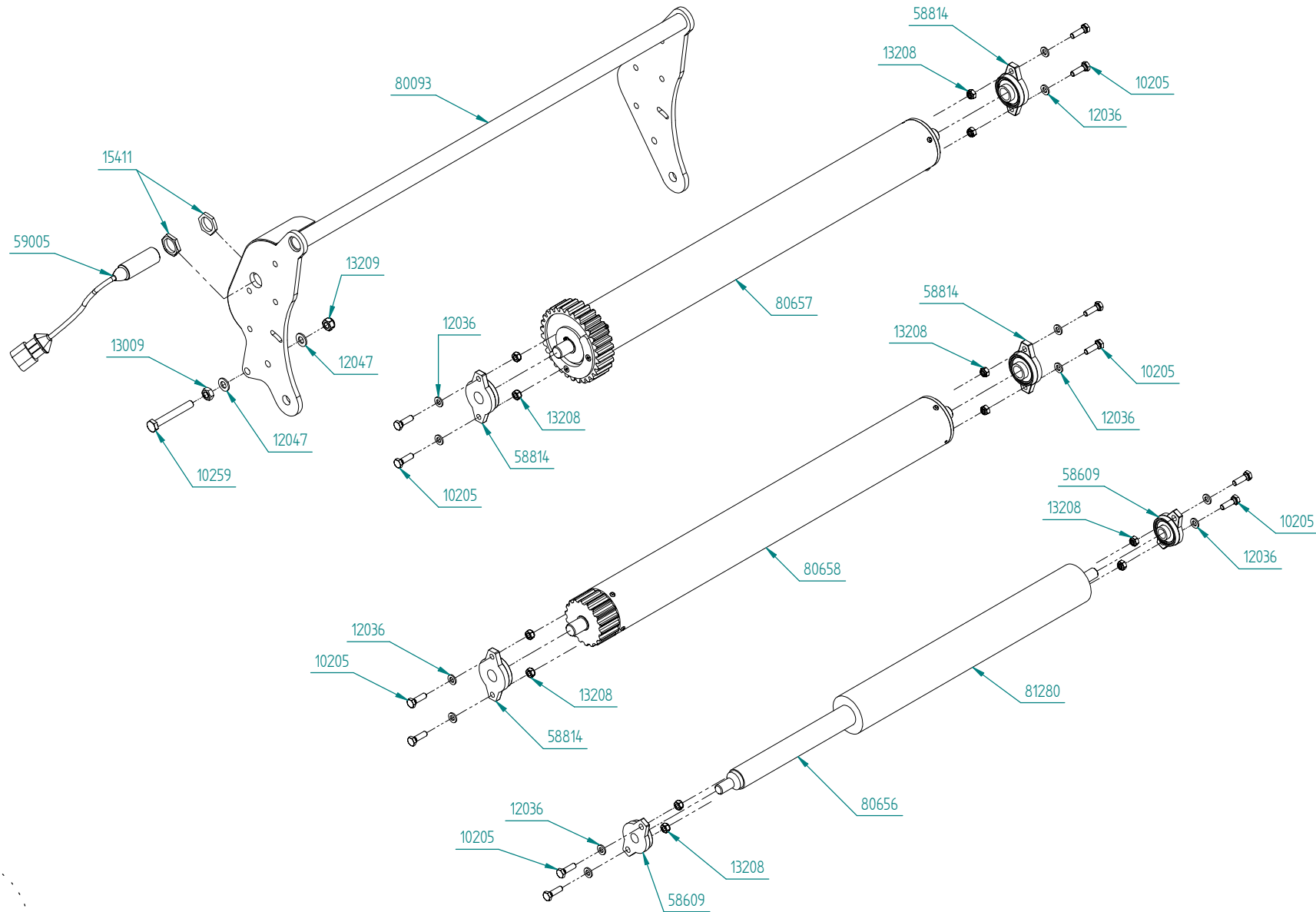

81279
Rollframe
assembly

Part Number	Qty.	Title
10205	22	Bolt M6x20, threaded to head
10240	1	Bolt M8x16
10246	1	Bolt M8x25
10259	2	Bolt M8x60
10348	2	Bolt M12x30
10352	16	Bolt M12x40
10404	4	Bolt M14x55, DIN 933
10581	2	Bolt M20x80
11303	2	Set screw M12x12
11334	1	Set screw
12029	8	Washer M5
12036	22	Washer M6
12047	4	Washer M8
12067	32	Washer M12
12072	4	Washer M14
12088	4	Washer M20
12147	1	Washer $\varnothing 24/8,4 \times 2$
12159	3	Washer $\varnothing 18/6,4$
12178	1	Washer $\varnothing 37/13 \times 3$
12189	1	Washer $\varnothing 40/9 \times 4$
13009	4	Nut M8
13207	8	Lock nut M5
13208	22	Lock nut M6
13209	2	Lock nut M8

Part Number	Qty.	Title
13211	17	Lock nut M12
13212	4	Lock nut M14
13215	2	Lock nut M20
14105	4	Splint $\varnothing 8 \times 50$
15158	8	Bolt M5x50, cylinderhead
15161	2	Bolt M12x45, cylinderhead
15231	3	Bolt M6x12 DIN 933
15411	6	Lock nut M18
15544	1	Circlip
15752	4	Spring washer M12
35633	1	Bonded seal 1/4"
50805	1	Key 10x8x50
53306	4	Gasket 1/2"
56996	2	Stop switch
57092	1	Bracket, charcoal
57093	1	Capsule set
58527	1	Bearing housing
58609	4	Bearing UFL000N
58635	1	Fitting 1/4"-1/4"
58806	2	Bearing, lower
58813	4	Spring
58814	8	Bearing UFL002N
58905	1	Brake, wrapping arms
58991	1	Cover, top

Part Number	Qty.	Title
59005	3	Inductive transducer
59185	1	Fitting 1/2" - 1/2"
59205	1	BSP Tee 1/4"
59740	3	Fitting 1/4" - 1/2"
78214	2	Fastening bolt M10, film stretcher
80070	2	Plastic roll
80093	2	Film stretcher, frame, for rolls
80096	2	Film stretcher, frame 1
80097	2	Emergency stop arm with dampener
80103	1	Top frame, wrapping arms
80656	2	Free roll
80657	2	Primary roll
80658	2	Secondary roll
81069	1	Housing
81070	1	Cartridge valve WS10W
81071	1	Safety valve
81077	1	Coil for WS10W 12V
81256	1	Plate for brake
81258	1	Sprocket
81259	1	Chain 1"
81260	1	Chain guard
81261	2	Bearing
81263	2	Diaphragm grommet 25
81264	2	Wrapper arm

Part Number	Qty.	Title
81266	2	Spring tensioner
81267	1	Rotating arms axle
81268	1	Rubber plug 37x3
81269	2	Rubber grommet 12x7
81270	1	Motor
81271	1	Sealkit, motor
81272	1	Sealkit, brake
81273	2	Lever bracket
81274	4	Lever
81275	4	Grip M10
81276	2	Film holder upside
81277	2	Upper axle
81278	2	Spring
81280	2	Roll softer

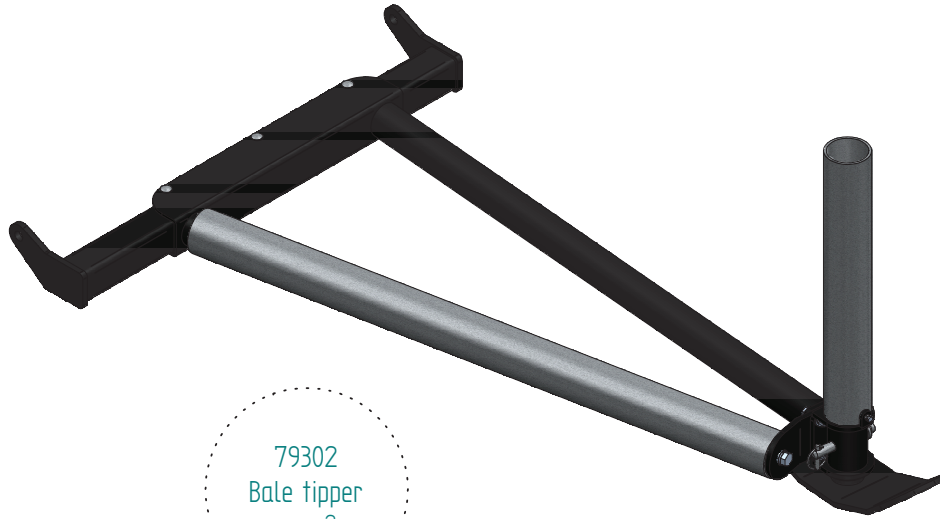

79302
Bale tipper
page 2

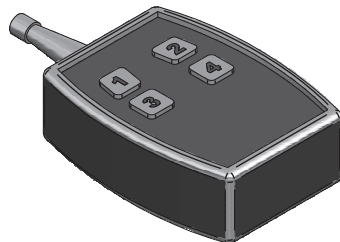

59644
Remote controller
page 3

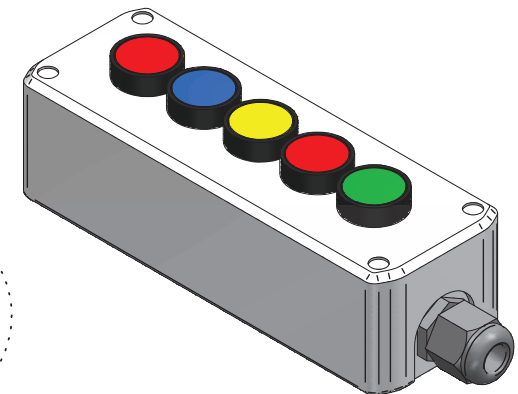

78902
Remote control
film system
page 3

Part Number	Qty.	Title
10207	1	Bolt M6x25, threaded to head
10307	4	Bolt M10x50
10493	1	Bolt M16x50
11110	3	Lockinghead bolt M10x100
12060	11	Washer M10
12078	1	Washer M16
12278	1	Spring washer M16
13008	1	Nut M6
13043	3	Lock nut M10
13210	4	Lock nut M10
79298	1	Bale stopper
79299	1	Support leg
79303	1	Bracket, welded
79304	1	Bracket, triangle
79394	1	Front bracket for triangle
79395	1	PVC pipe triangle
79396	1	PVC pipe vertical MC
81305	1	Locking bolt with pin, 19x95

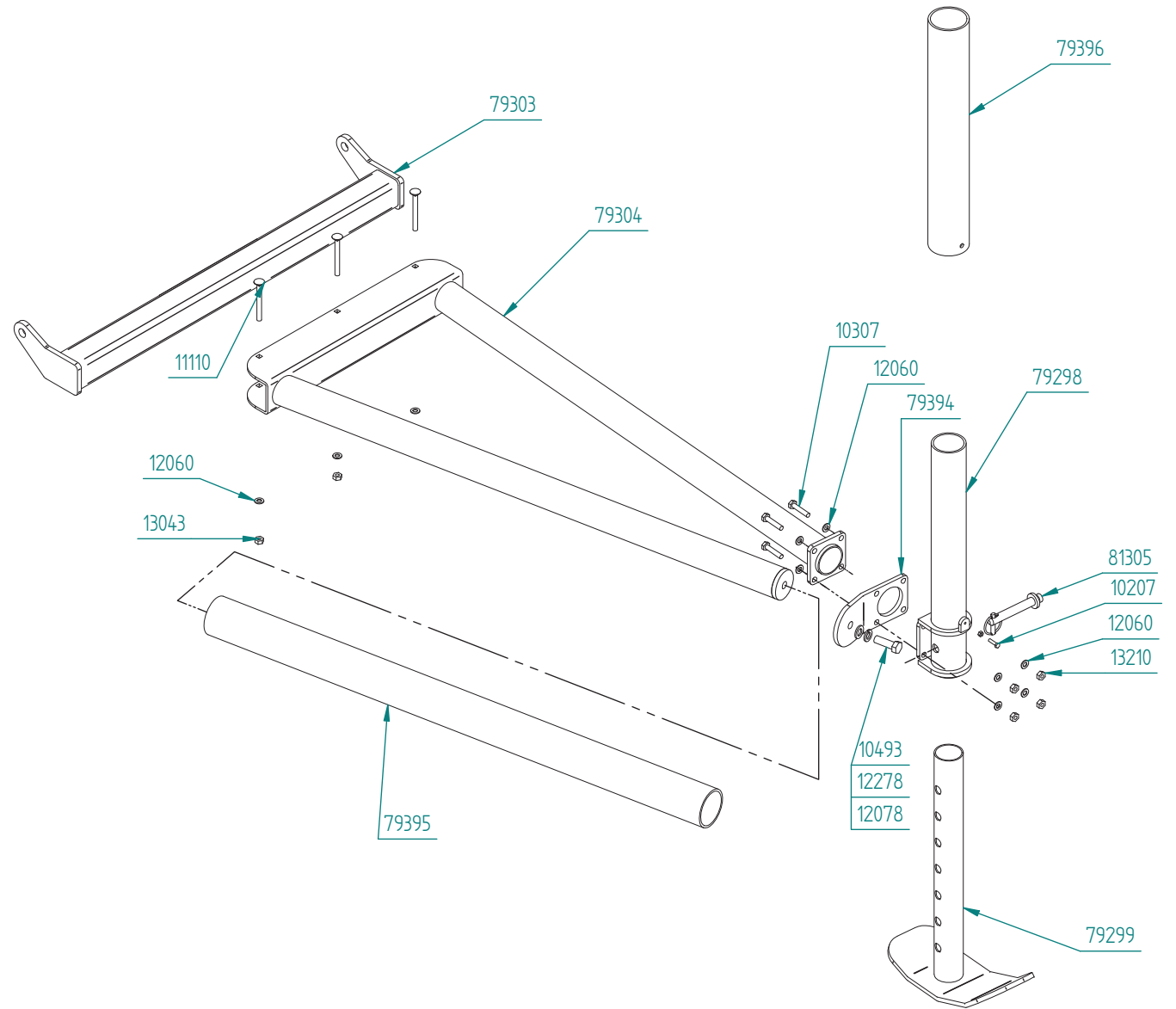

Part Number	Qty.	Title
78902	1	Switch box film system
59644	1	Remote Controller

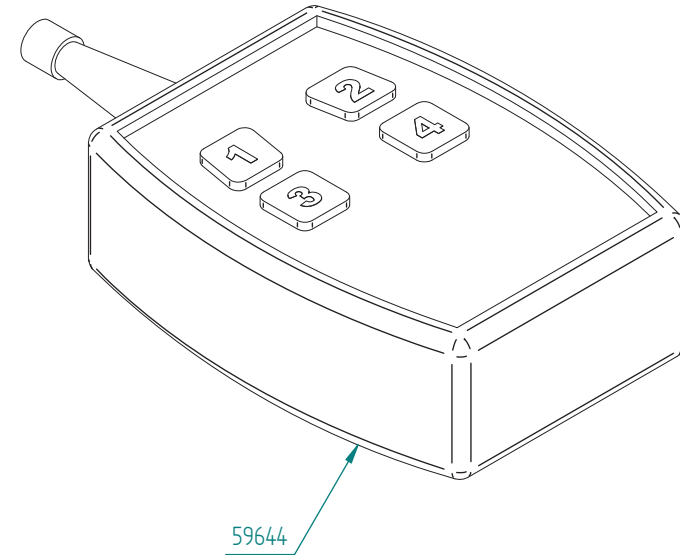
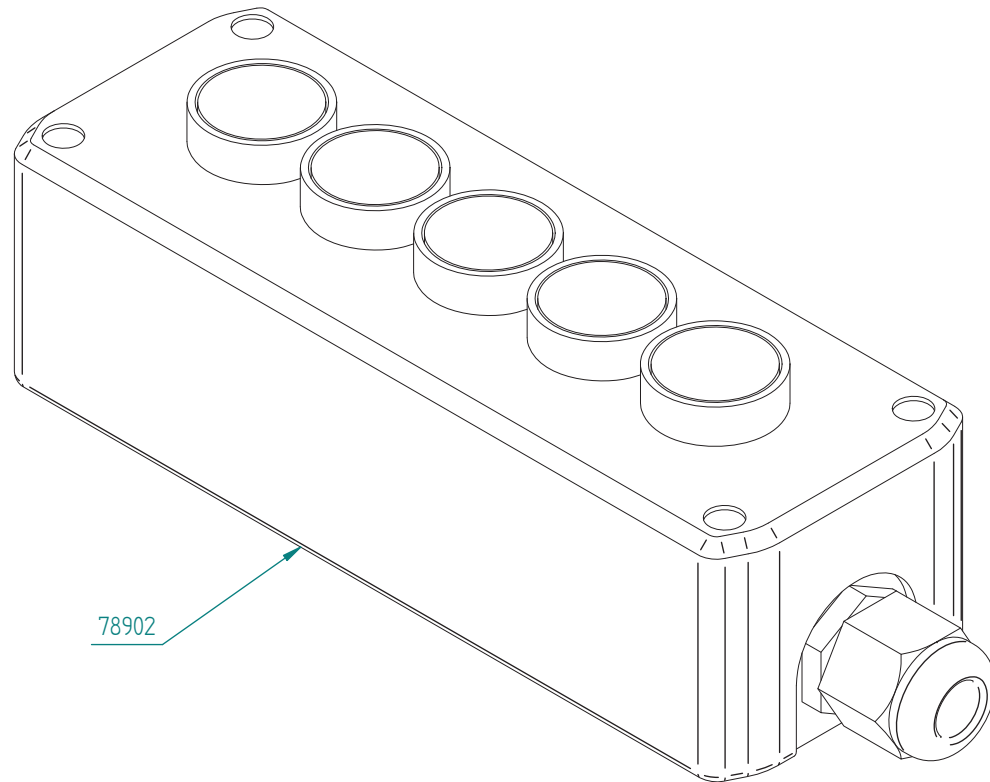

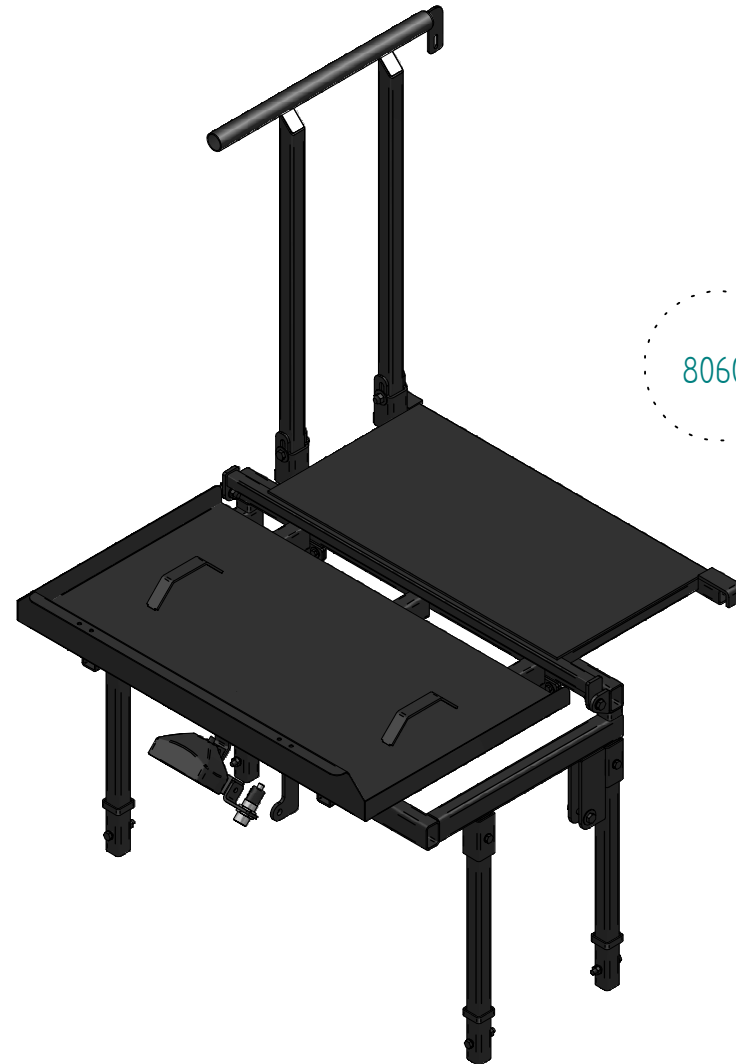

80602

Part Number	Qty.	Title
10246	8	Bolt M8x25
10312	8	Bolt M10x70
10352	2	Bolt M12x40
10359	2	Bolt M12x60
10362	2	Bolt M12x75
12060	16	Washer M10
12067	4	Washer M12
12173	16	Washer $\varnothing 24/8,4 \times 2$
12177	8	Washer $\varnothing 35/12,5 \times 3$
13209	8	Lock nut M8
13210	8	Lock nut M10
13211	6	Lock nut M12
59581	1	Flood light
77240	1	Inner bracket, ultrasound sensor
77241	1	Outer bracket, ultrasound sensor
77514	1	Handrails, repos
77611	1	Bracket, light/ultrasound sensor
77892	4	Foot, rear railing, supporting frame
77893	1	Repos, supporting frame
77894	1	Repos
77920	1	Storage frame
80867	1	Ultrasonic sensor

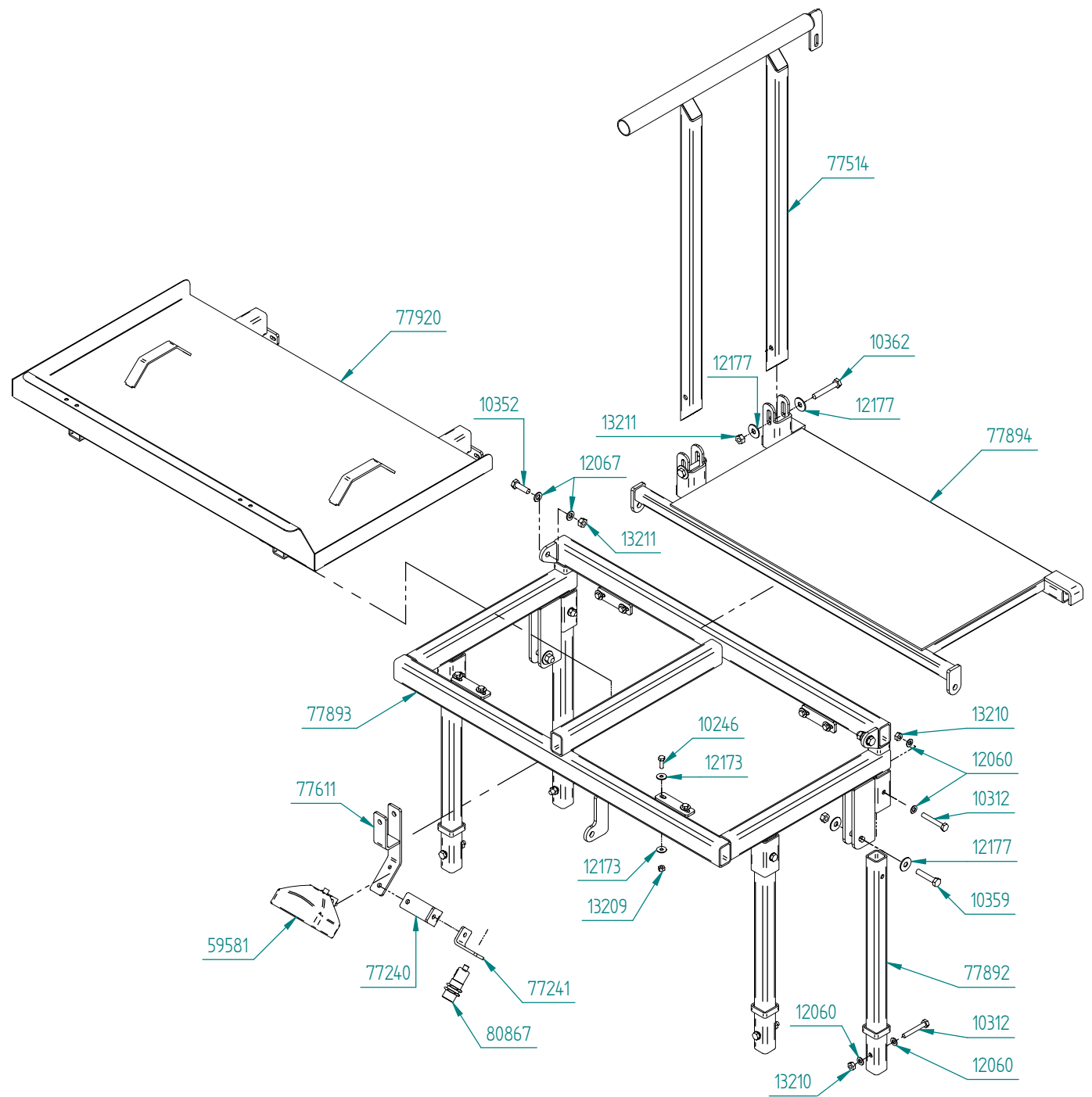

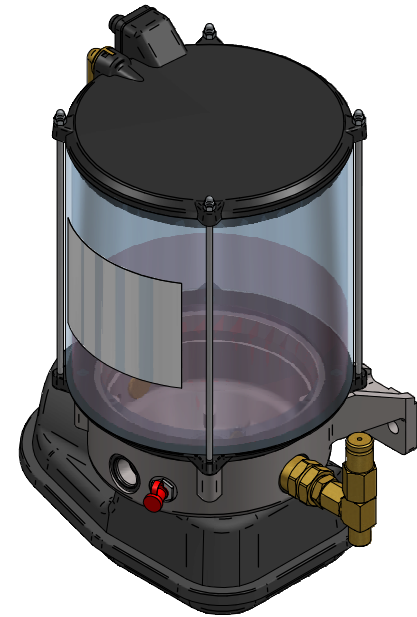
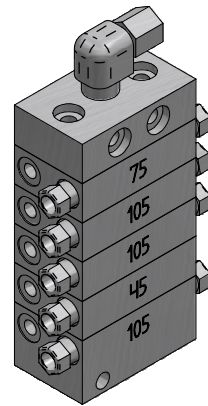
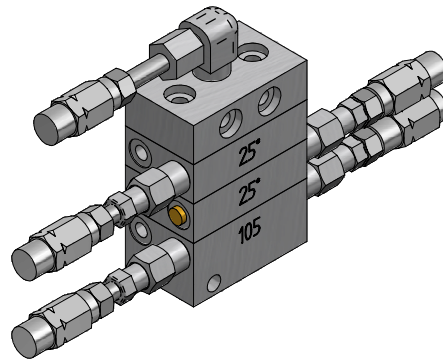
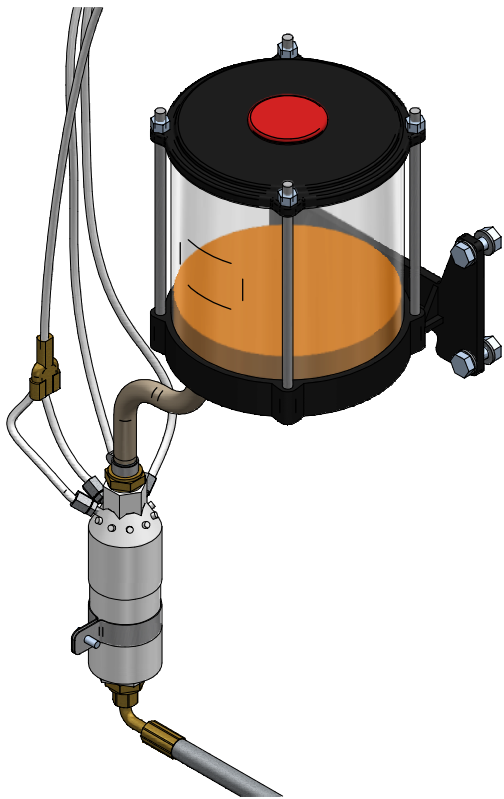

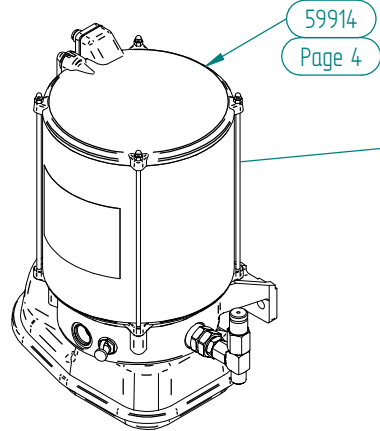

59914
Page 4

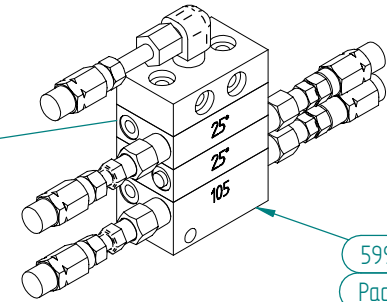
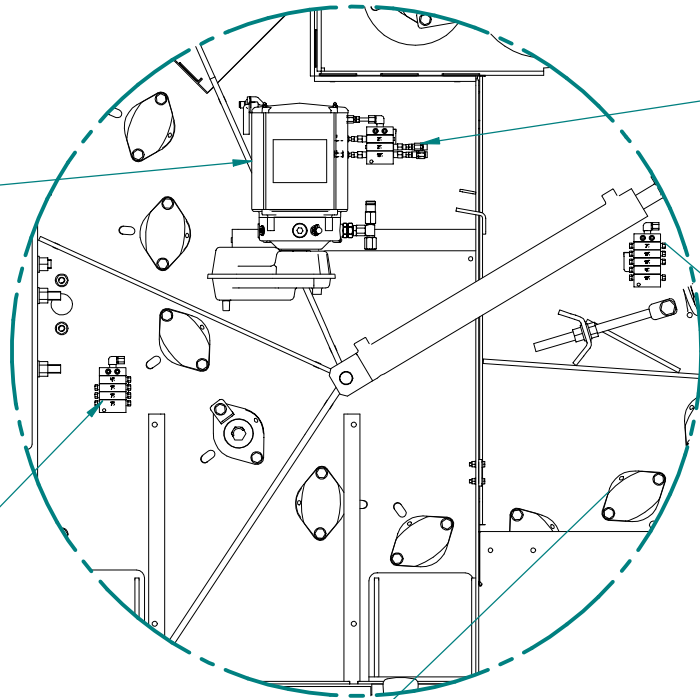

59920
Page 5

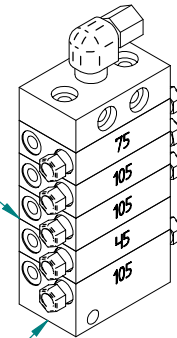

59923
Page 7

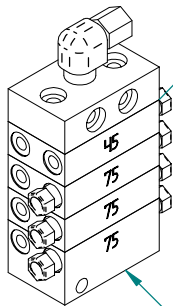

59924
Page 6

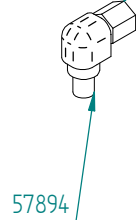

57894

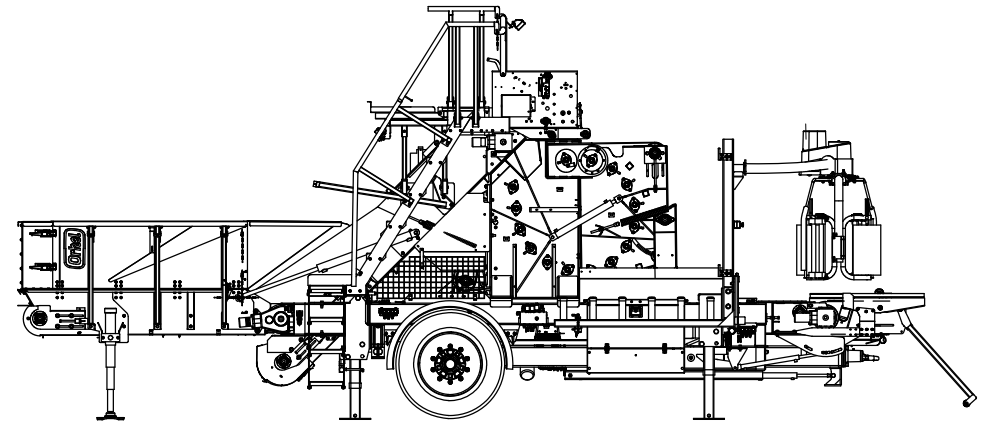

Compactor
right side

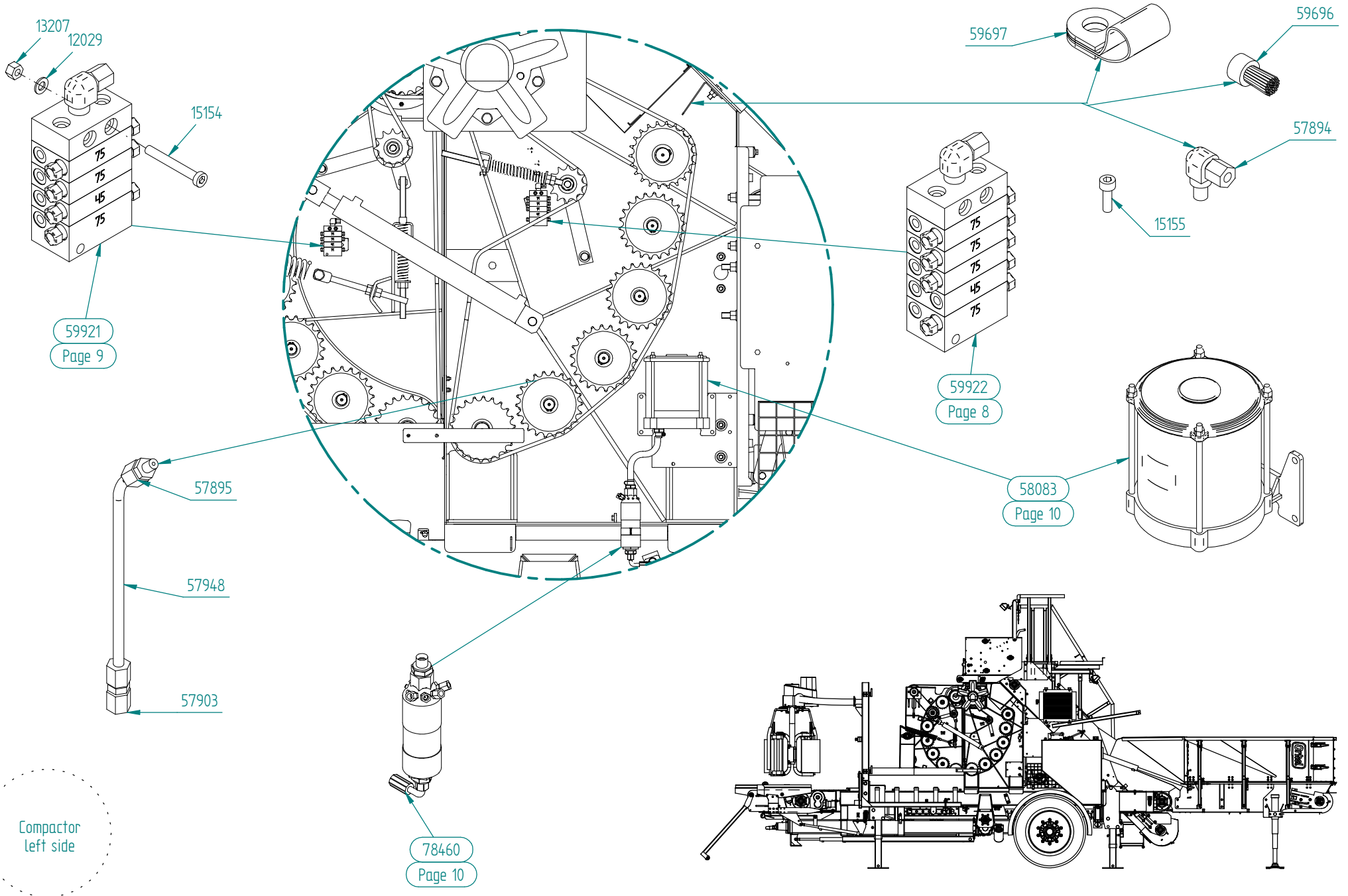

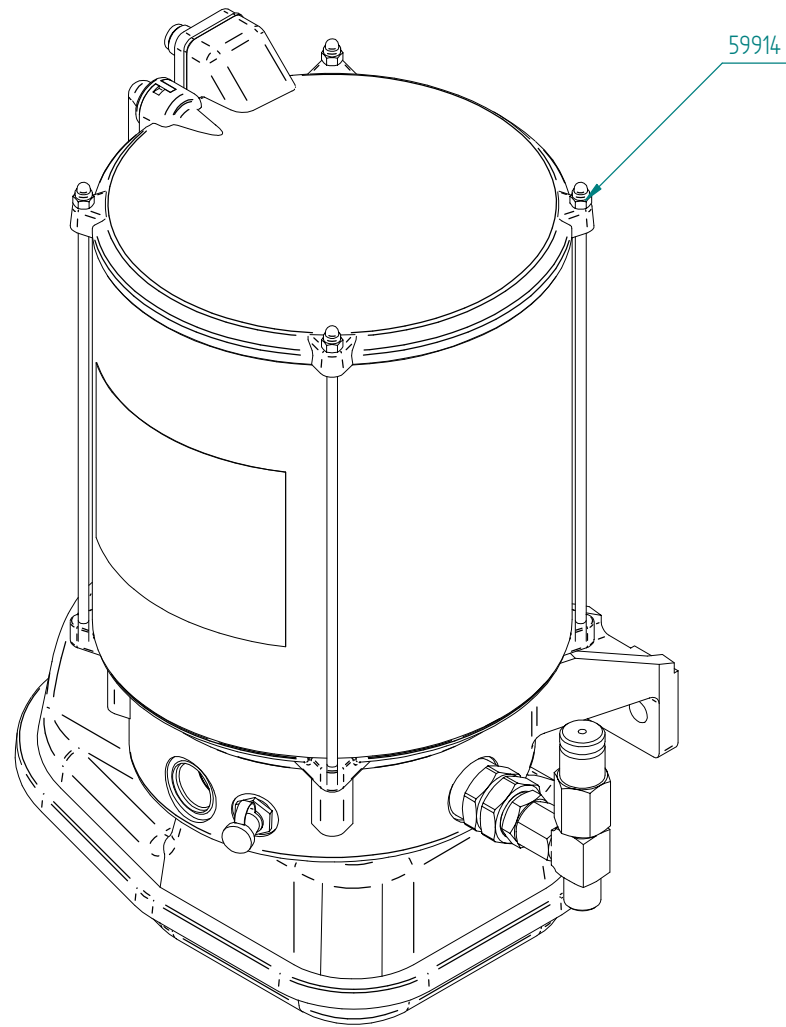

Electric pump

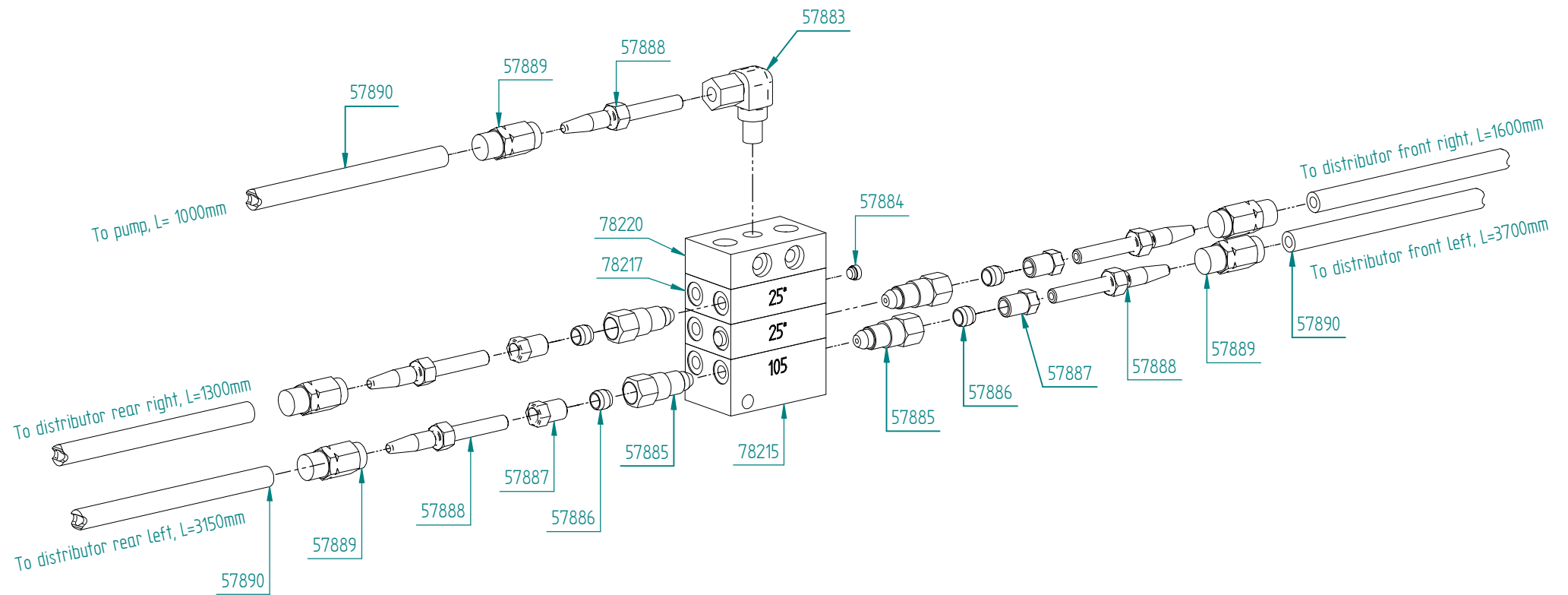

Main distributor
59920

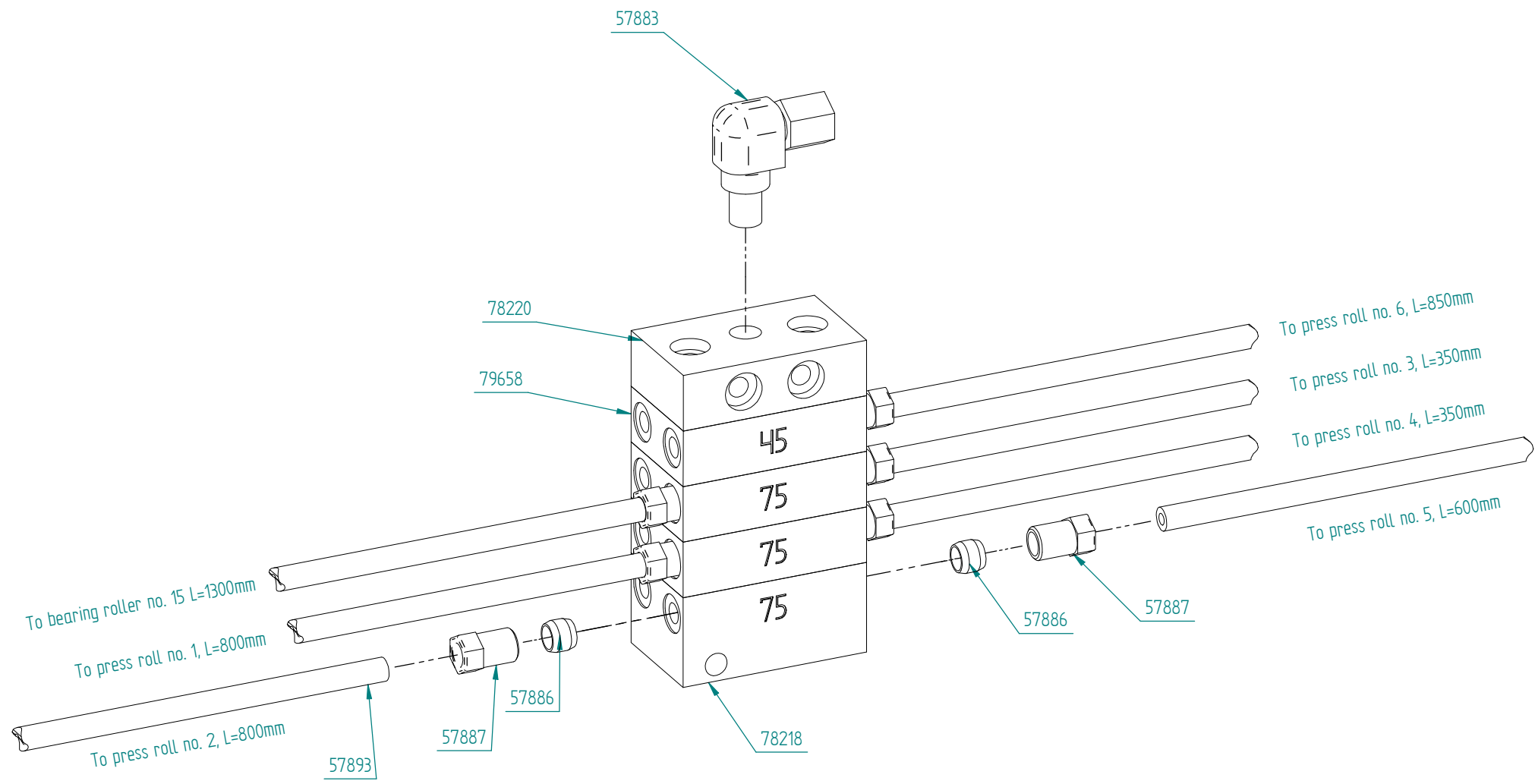

Distributor
rear right
59924

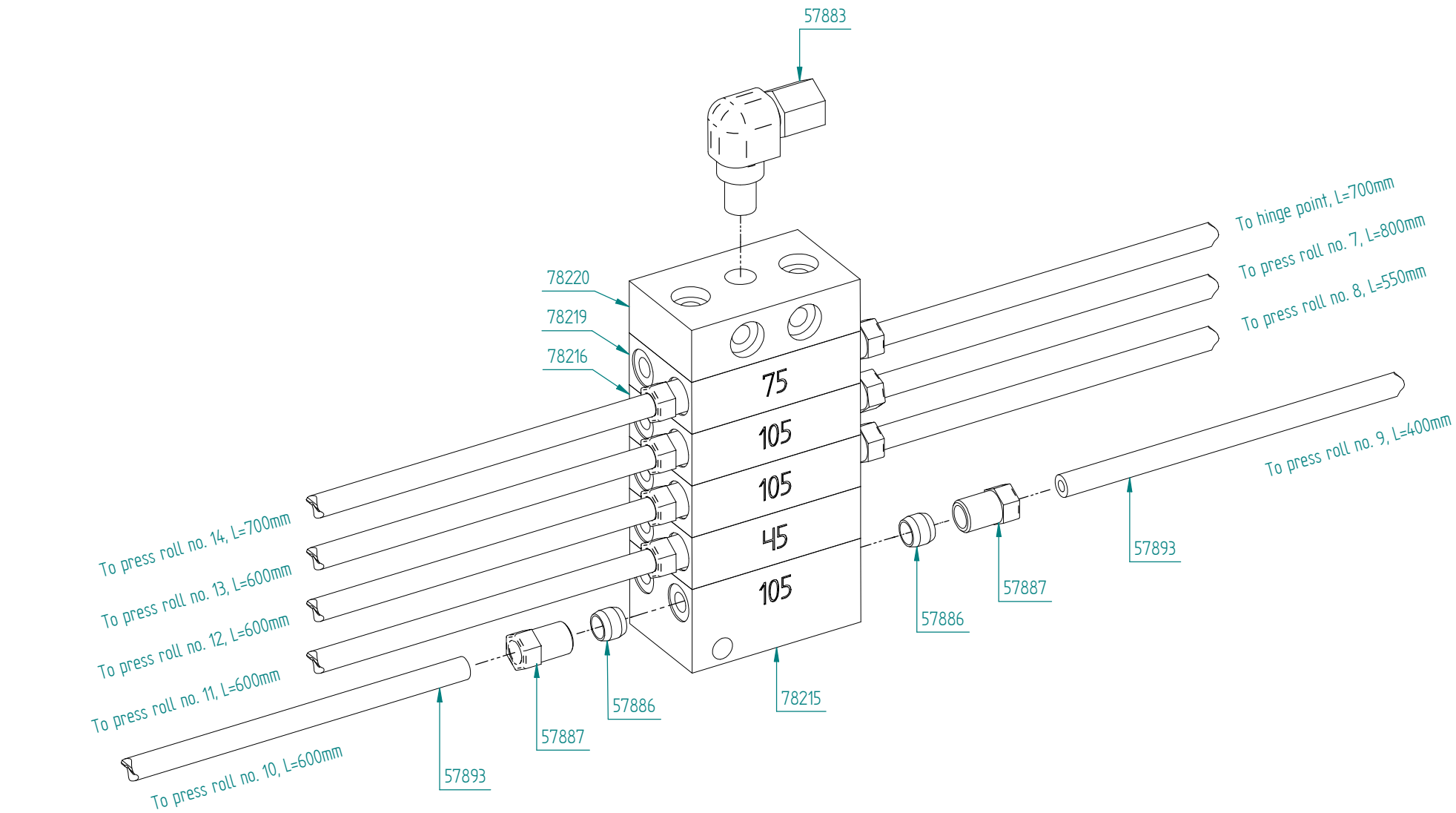

Distributor
front right
59923

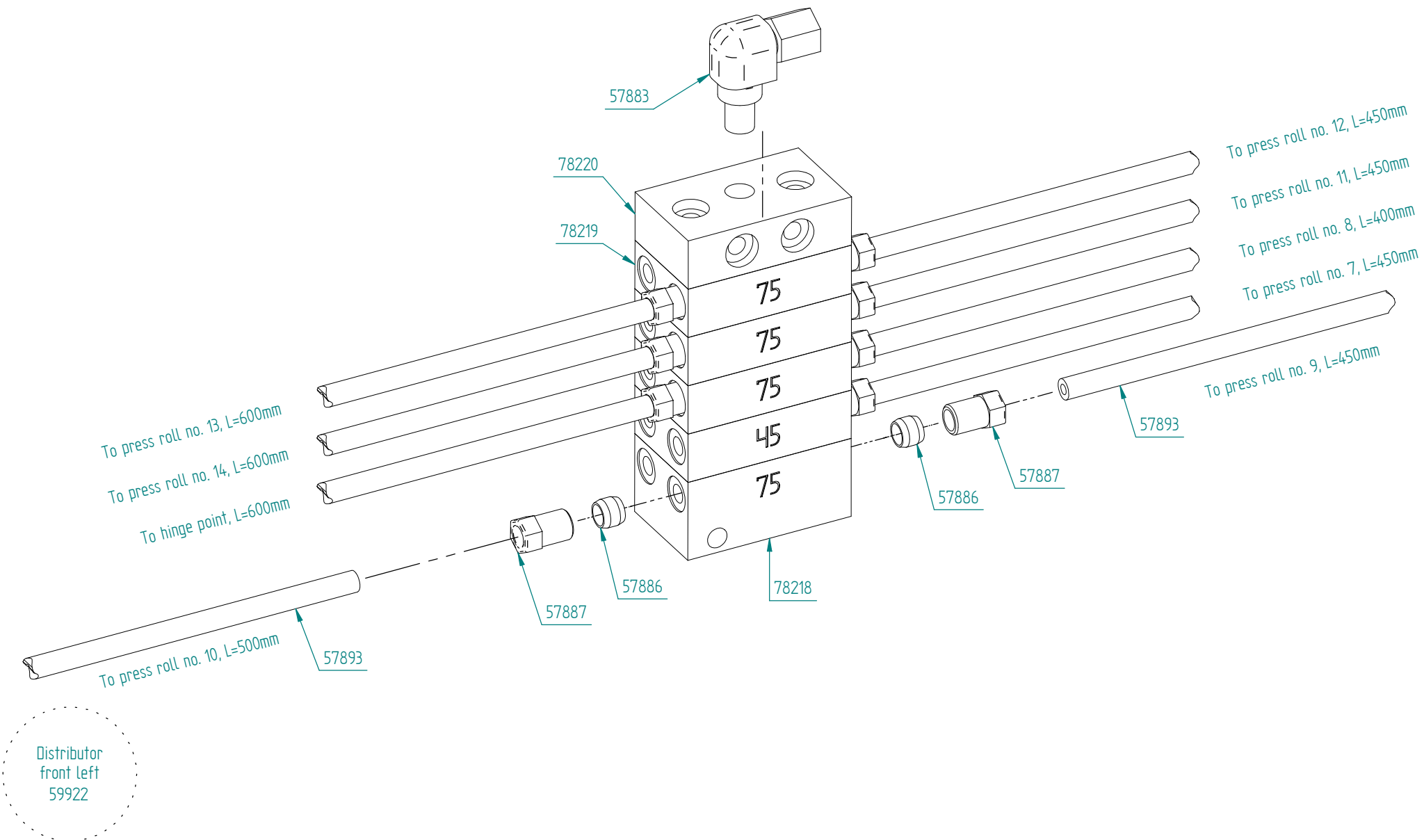

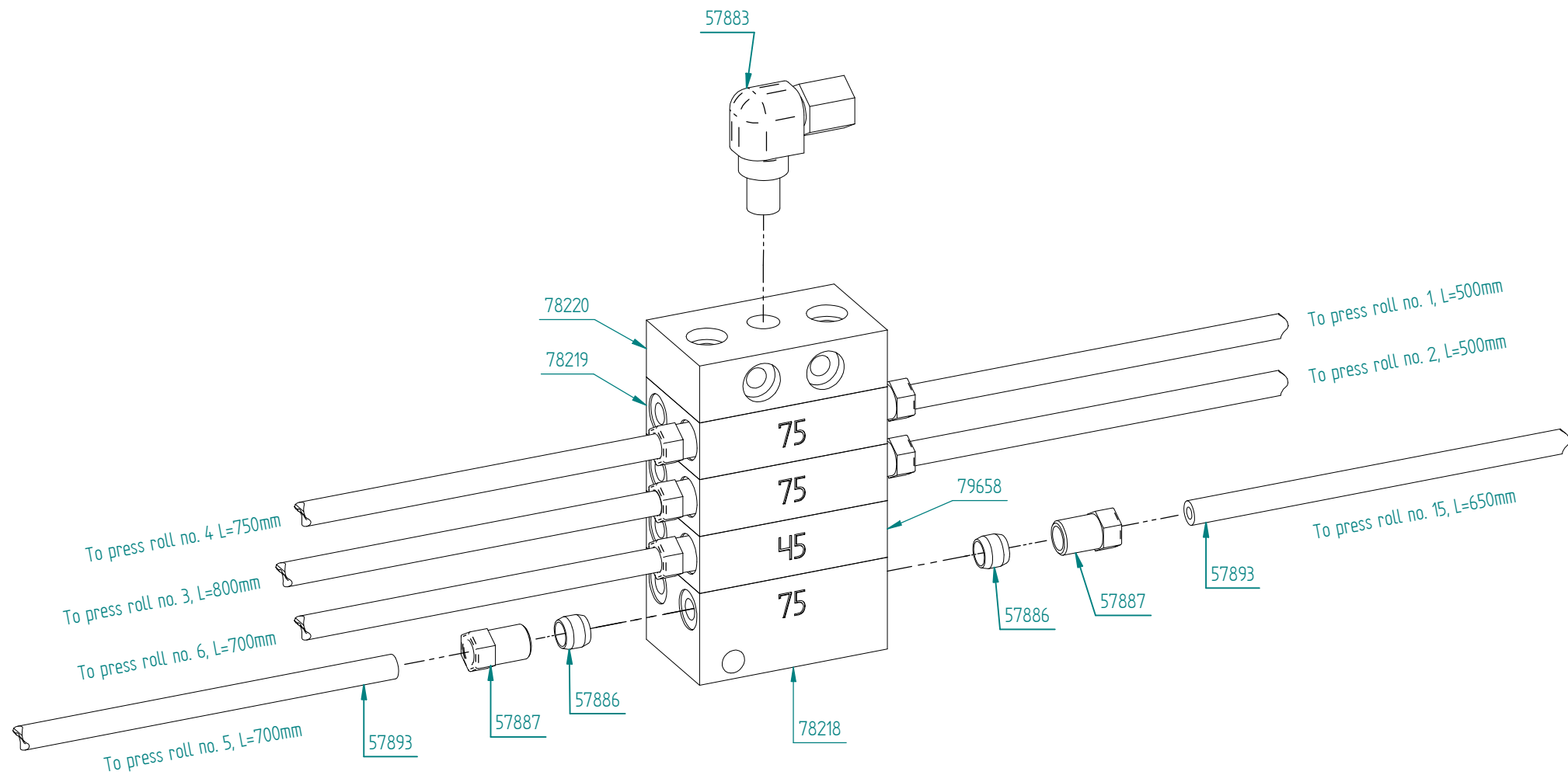

Distributor
rear left
59921

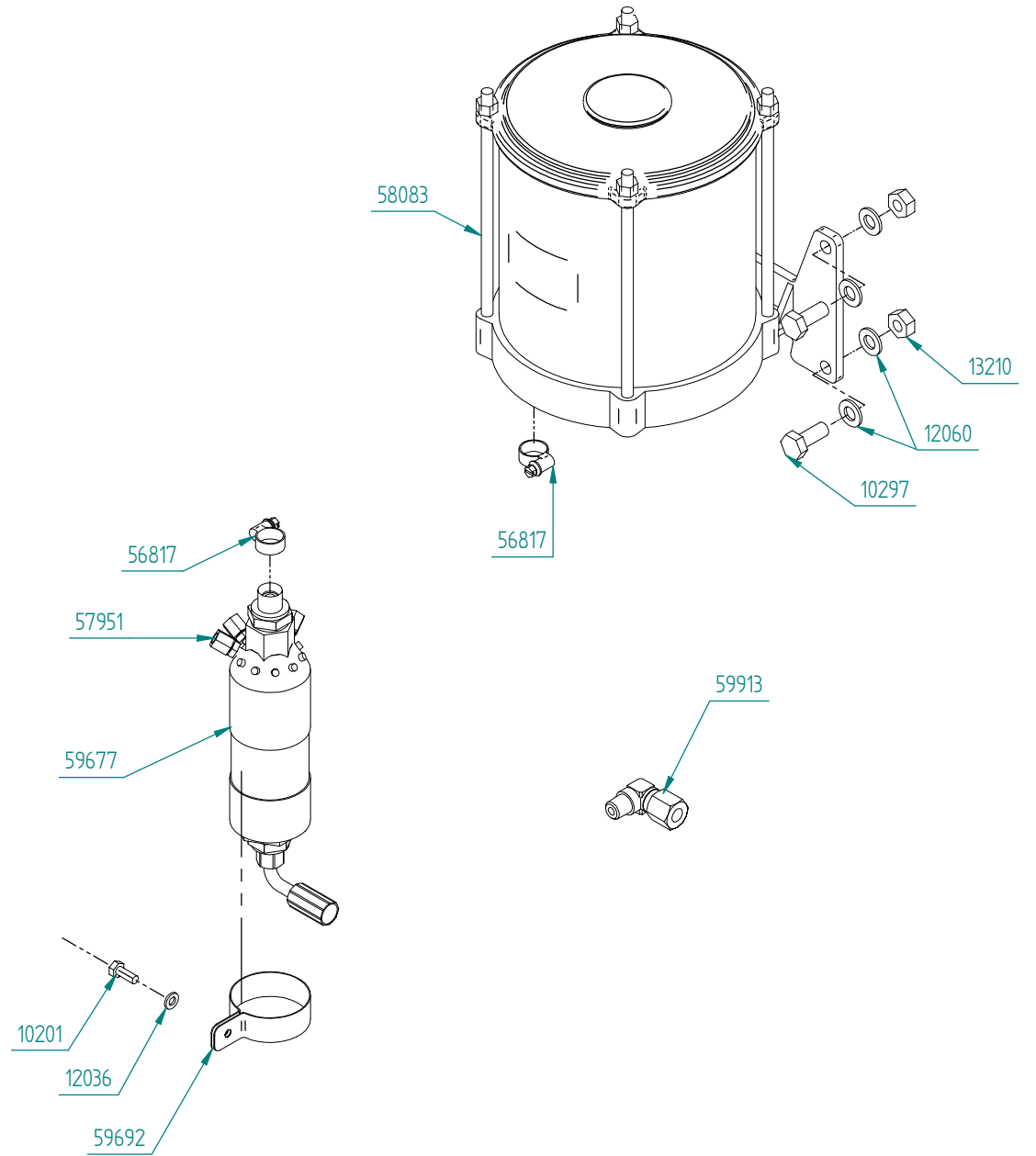
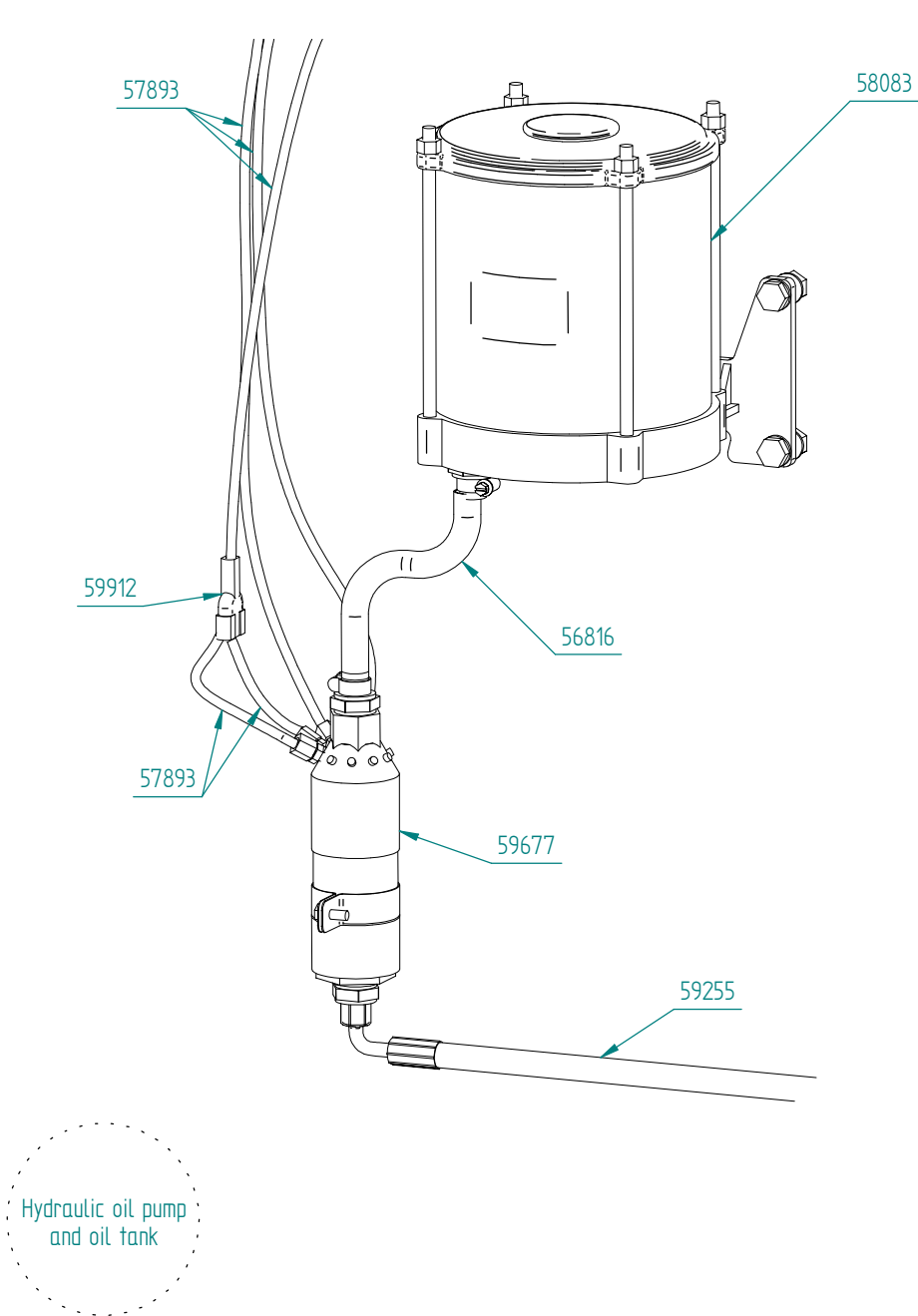

Document Number	Qty.	Title
10201	1	Bolt M6x16, threaded to head
10297	6	Bolt M10x25
12029	10	Washer M5
12036	1	Washer M6
12060	12	Washer M10
13207	10	Lock nut M5
13210	6	Lock nut M10
15154	10	Bolt M5x40, cylinderhead
15155	3	Bolt M5x16, cylinderhead
56816	1	PVC hose
56817	2	Worm gear clamp
57883	5	Angular coupling 90° WE6 1/8"
57884	2	Sealing plug
57885	4	Non-return valve
57886	36	Double Cone Olive
57887	36	Cap screw US6 M10x1
57888	9	Insert for ferrule
57889	9	Threaded ferrule
57890	m	High Pressure Hose
57893	m	Polyamid tube
57894	13	Elbow 90° WEG 1/8" K
57895	21	Fitting GE 6LI R1/8" k
57896	13	Spiral protection ø8x4
57903	16	Fitting

Document Number	Qty.	Title
57948	16	Steel tube, ø6x1, galvanized
57951	2	Fitting
58083	1	Oil reservoir
59255	1	Hydraulic hose 1/4"
59677	1	Hydraulic pump
59692	1	Clamp
59696	3	Grease brush
59697	3	Tube bow ø15
59908	2	Straight connector GE6 M6
59912	1	Fitting Y-type
59913	3	Elbow connector M8x1k
59914	1	Electric pump, EP-1
59920	1	Main distributor MX-F 3/4
59921	1	Distributor rear left
59922	1	Distributor front left
59923	1	Distributor front right
59924	1	Distributor rear right
78215	2	Distribution block, MX-F 105, large
78216	2	Distribution block, MX-F 105, small
78217	2	Distribution block, MX-F 25, small
78218	3	Distribution block, MX-F 75, large
78219	8	Distribution block, MX-F 75, small
78220	5	Distribution block, MX-F 105, main
79658	4	Distribution block, MX-F 45, small



Developing profitable customers

CONTACT



Johan Gjønnes' veg 25
7320 Fannrem
Norway



Spare parts:
+47 913 23 511

Technical Support:
+47 918 43 553



parts@orkel.no



orkel.com

User resources



orkel.com/qr/flex