

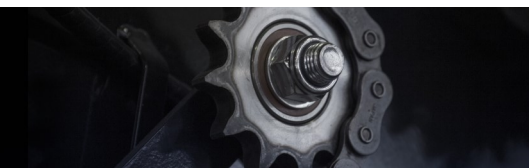

Developing profitable customers



MP2000-X COMPACTOR **PARTS LIST**



This parts list

Version: MP2000-X.PL.1E
From chassis number: 20427004

Instructions for ordering spare parts

Illustrated parts are marked with part numbers.

To avoid errors, each part order must include the following information:

- Part number and description of part
- Quantity of parts required
- Chassis number

The chassis number is stamped into the model identification plate on the machine.
It is essential to quote this chassis number in full in all enquiries and spare part orders.

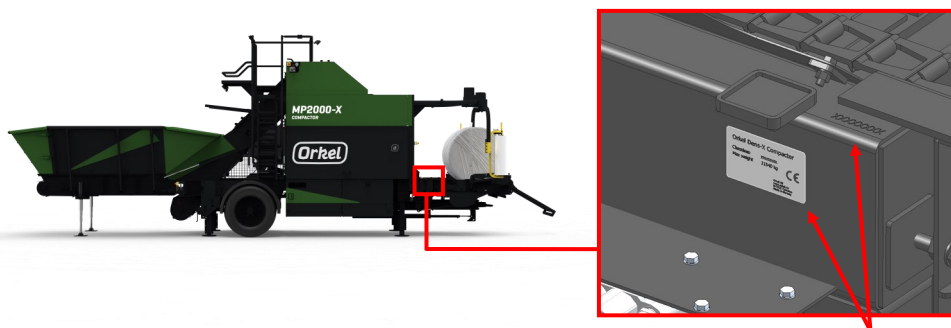

Chassis no.

Disclaimer

The original parts used on an Orkel® machine are designed and built to provide optimum fit, function, safety, and structural integrity. For this reason, Orkel® DOES NOT in any circumstance approve of the use of aftermarket, gray market, or imitation parts.

The information provided by Orkel® hereunder is provided “as is, where is” and with all faults, and the entire risk associated with such information is entirely with the Buyer.

Orkel® does not grant, explicitly or implicitly, to any party any patent rights, licenses, or any other IP rights, whether with regard to such information itself or anything described by such information.

Information provided in this document is proprietary to Orkel®, and Orkel® reserves the right, at its sole discretion, to make any changes or modification to the information in this document or to any products and services at any time without notice.

Orkel® does not assume responsibility for any damages associated with a machine and/or part failure caused by the use of parts other than genuine Orkel® replacement parts, neither do we assume responsibility for any changes to the product made after initial delivery.



Johan Gjønnnes' veg 25
7320 Fannrem
Norway



Spare parts:
+47 913 23 511
Technical Support:
+47 918 43 553



parts@orkel.no



orkel.com



User resources
orkel.no/qr/mp2000-x

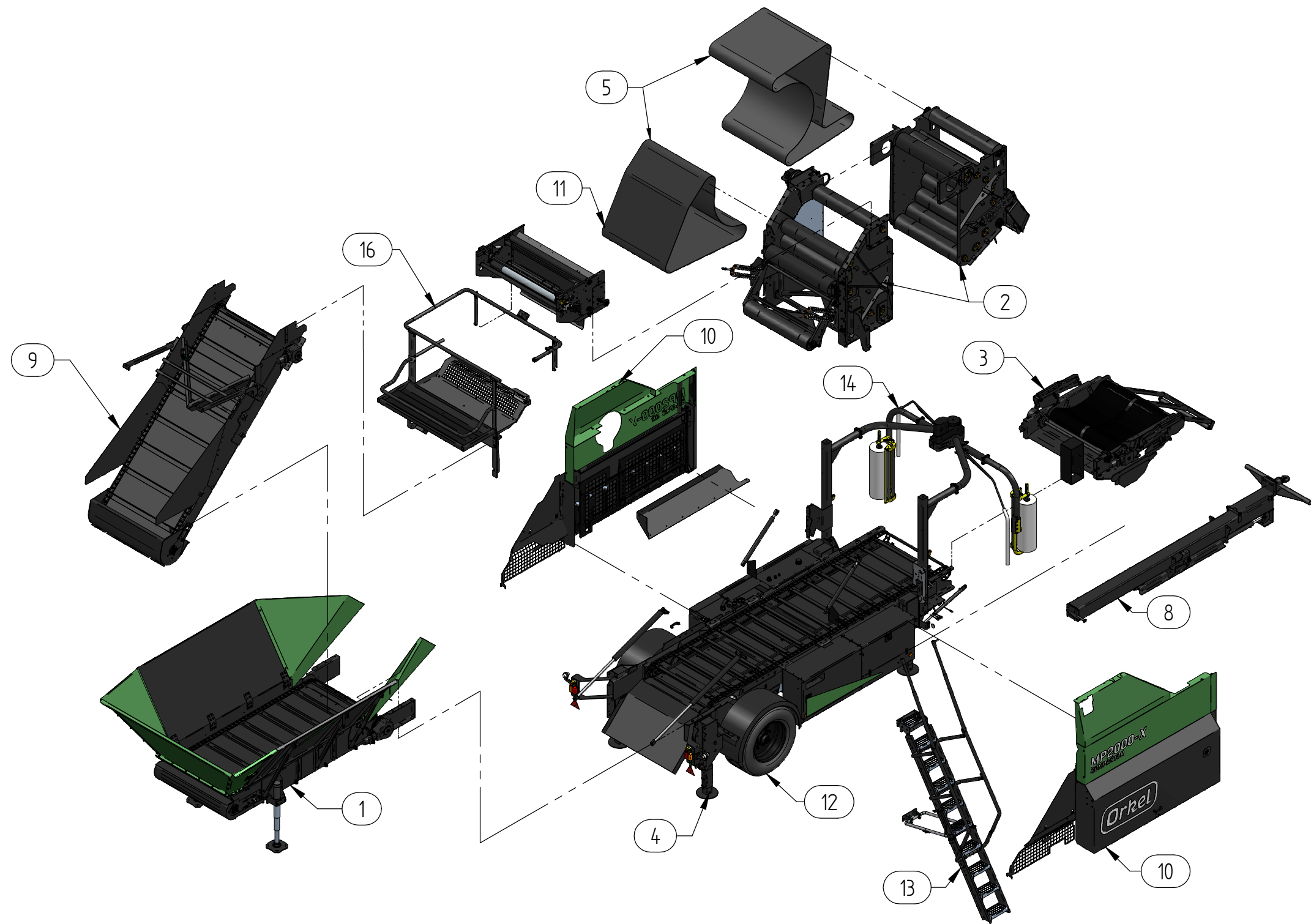

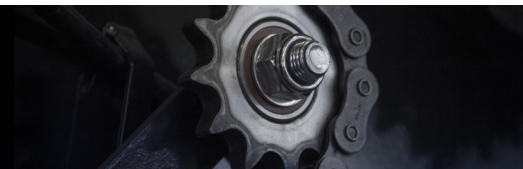

CONTENTS

- 1 Feed hopper F10
 - 2 (a) Front chamber
 - 3 (a) Wrapping table
 - 4 Frame
 - 5 Belts
 - 6 Hydraulics
 - 7 Electric
 - 8 Telescopic drawbar & PTO shaft
 - 9 Elevator
 - 10 Cover and film roll holder
 - 11 Plastic tying unit
 - 12 Wheel suspension
 - 13 Stairs
 - 14 Wrapping arms
 - 15 Optional equipment
 - 16 Platform
 - 17 Central lubrication system
- (b) Rear chamber
 - (b) Wrapping table with weighing system



77313

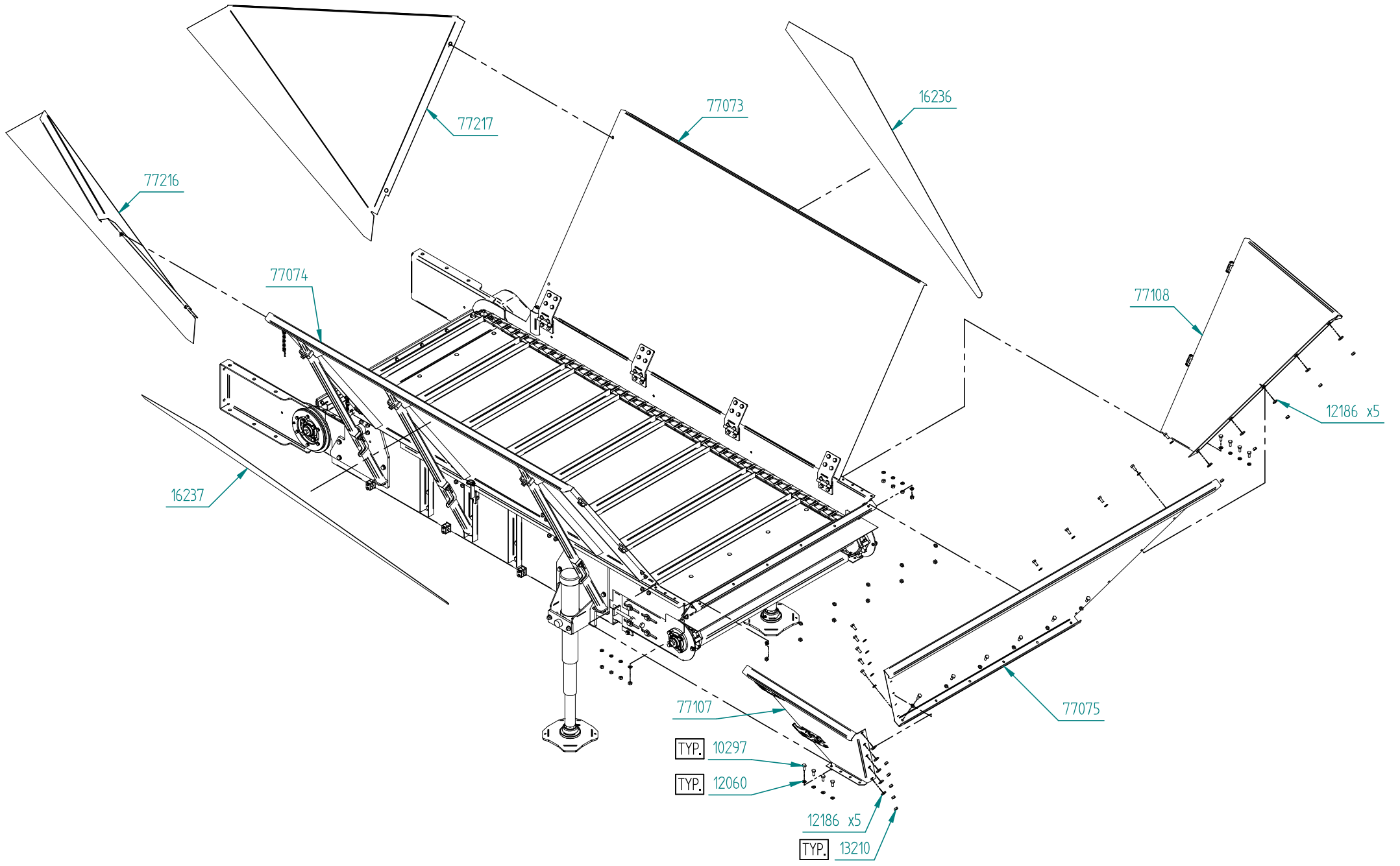

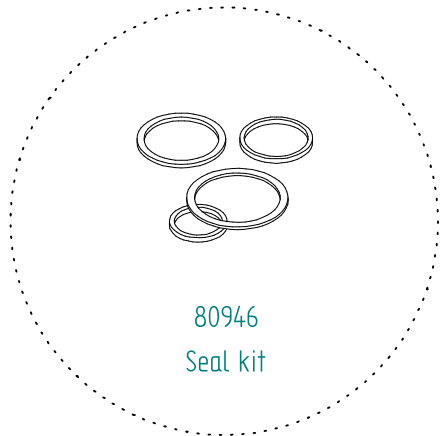

80946
Seal kit

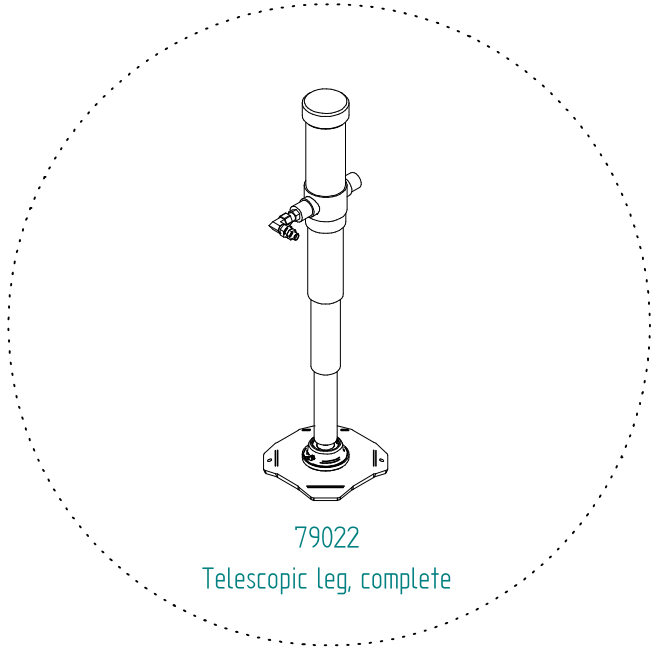

79022
Telescopic leg, complete

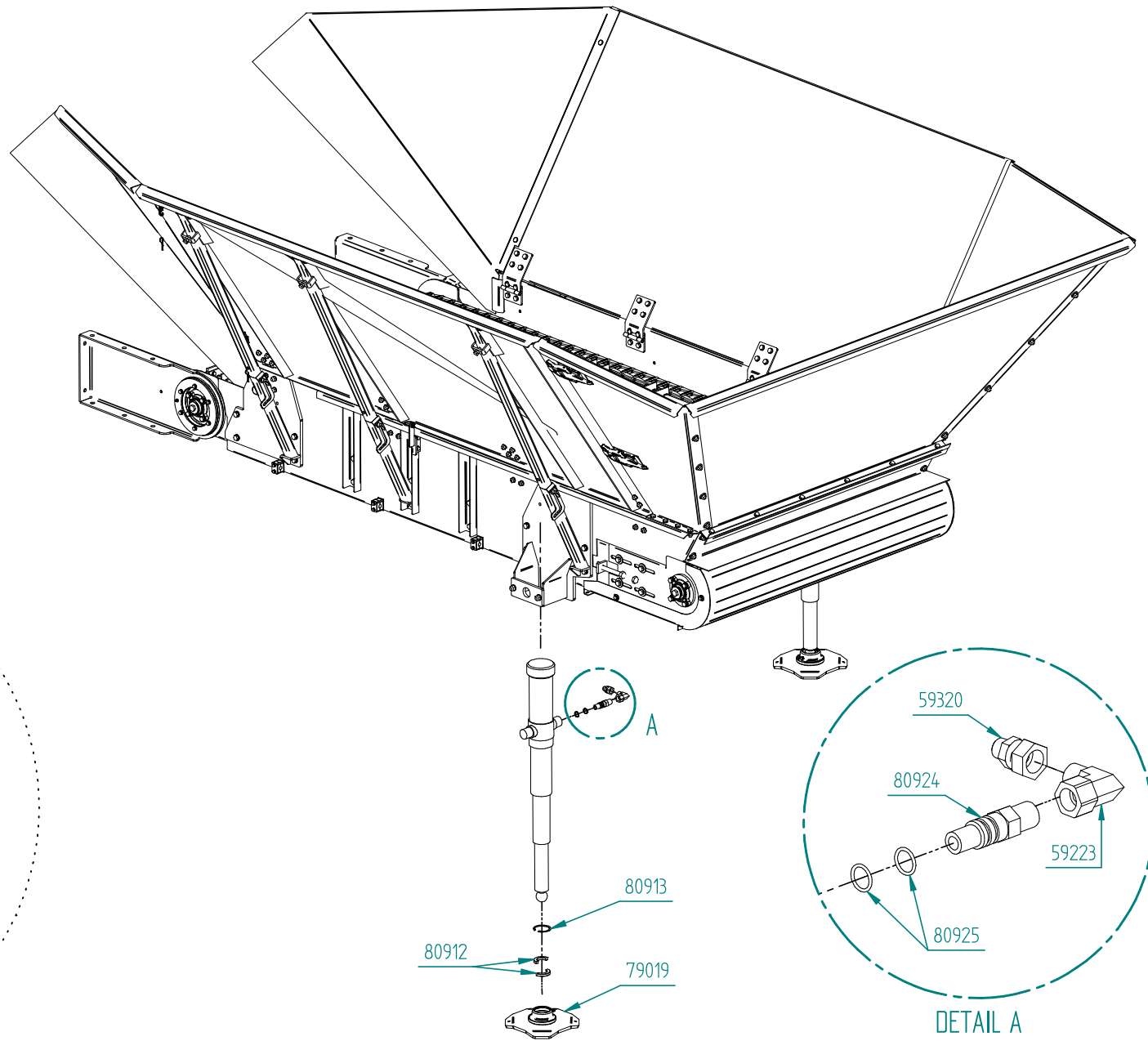

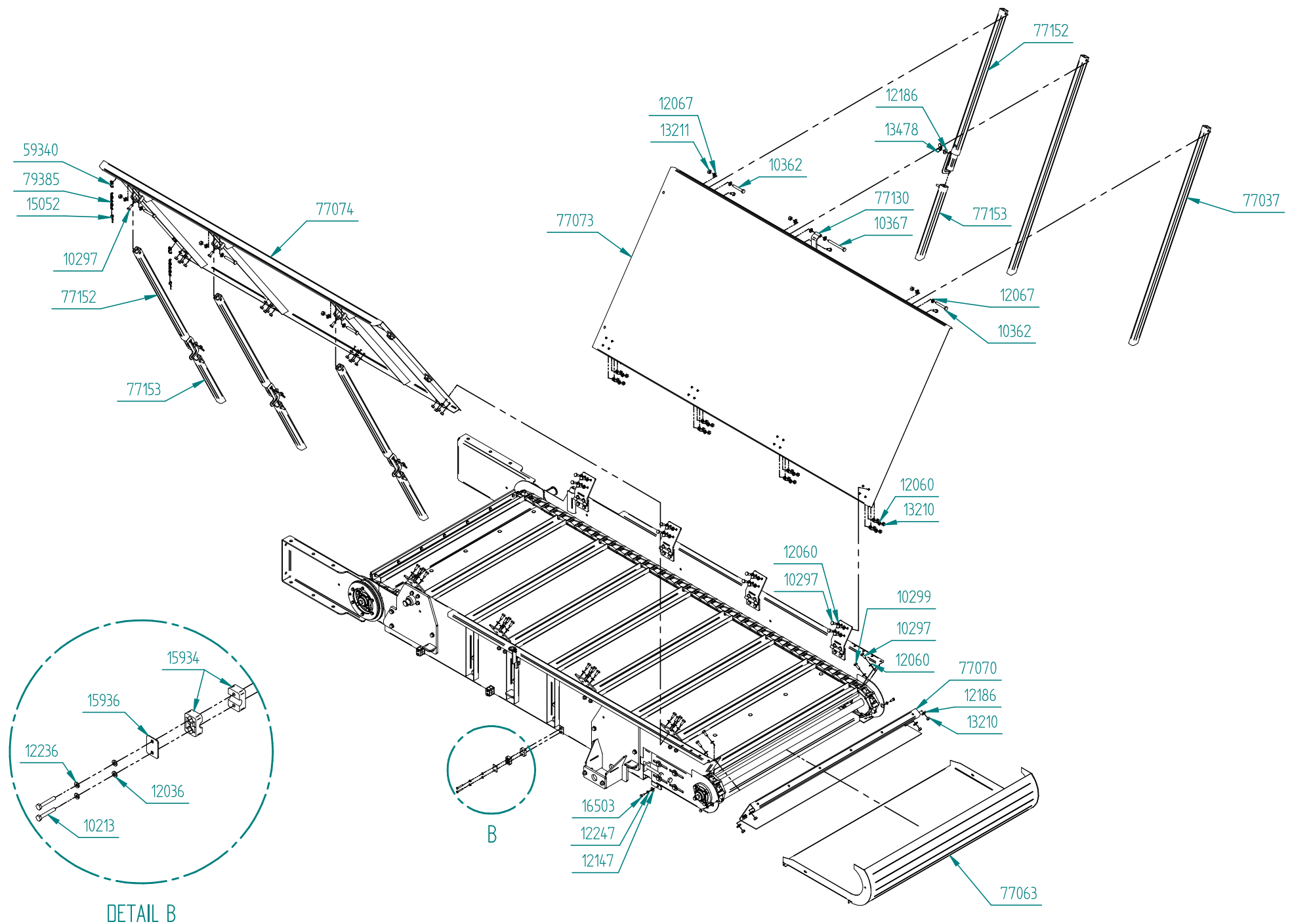

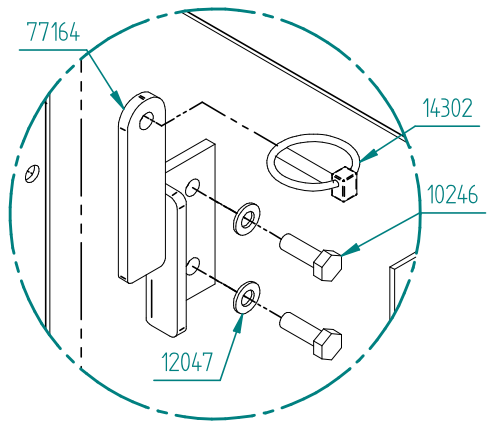
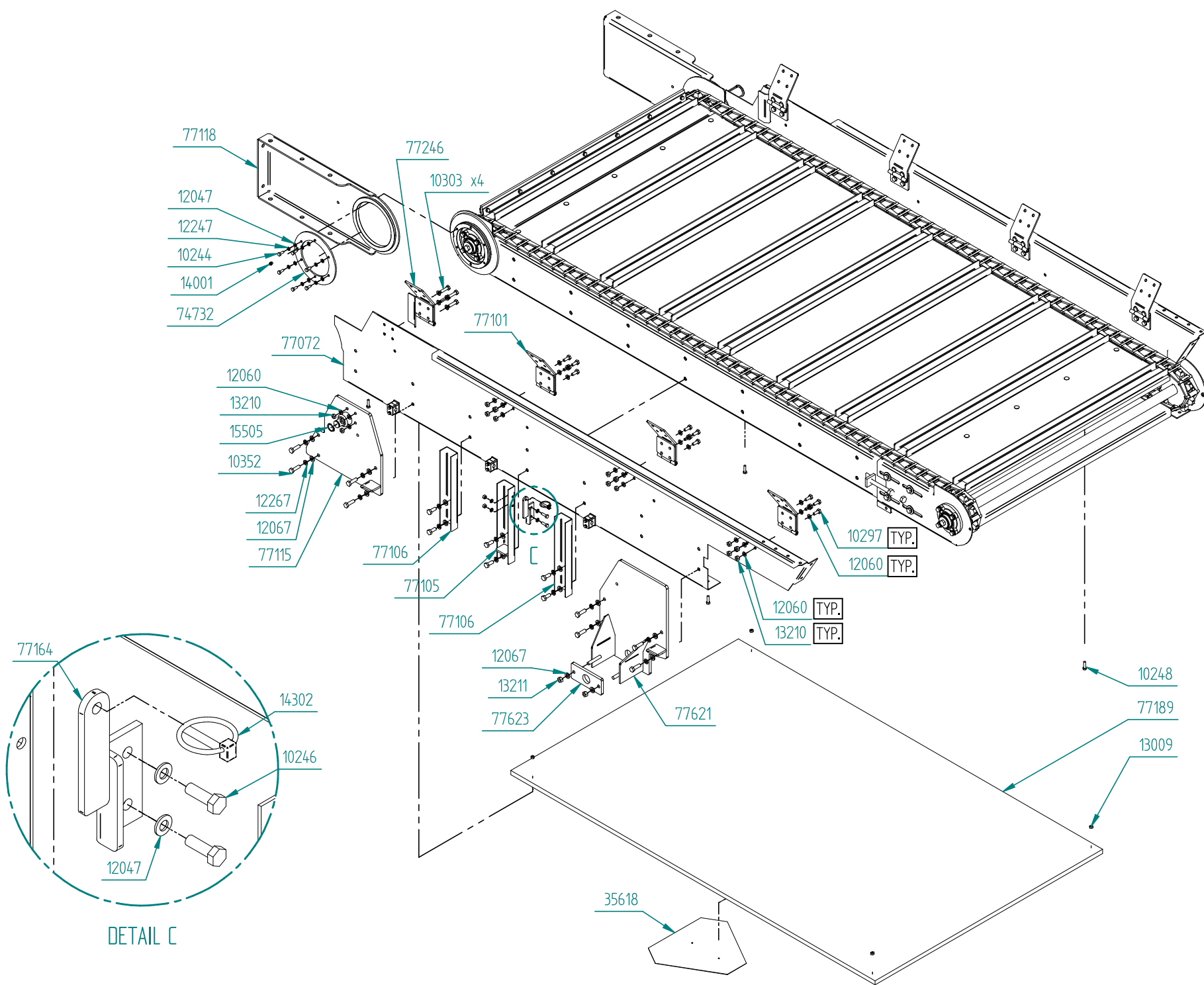

DETAIL C

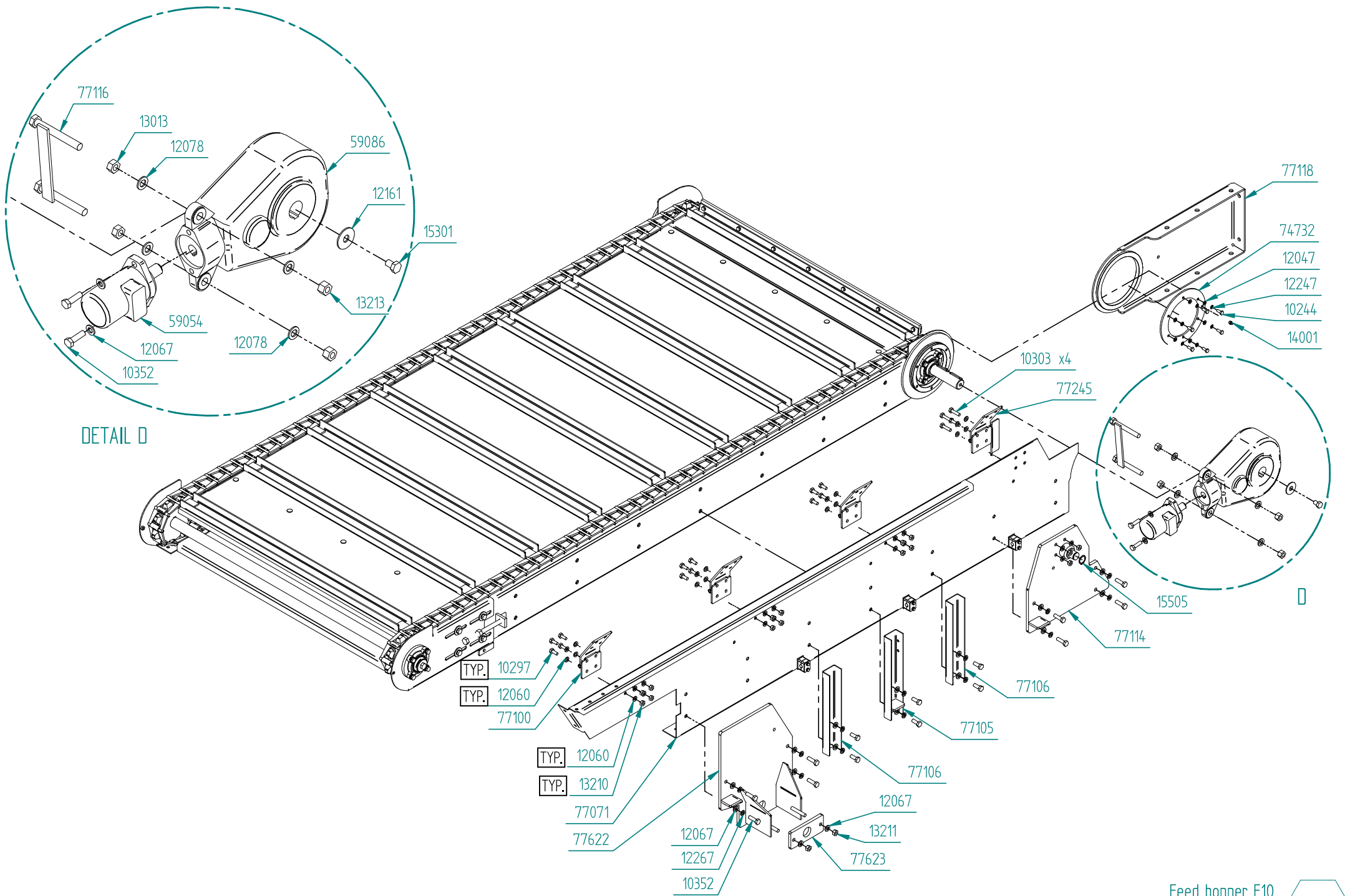

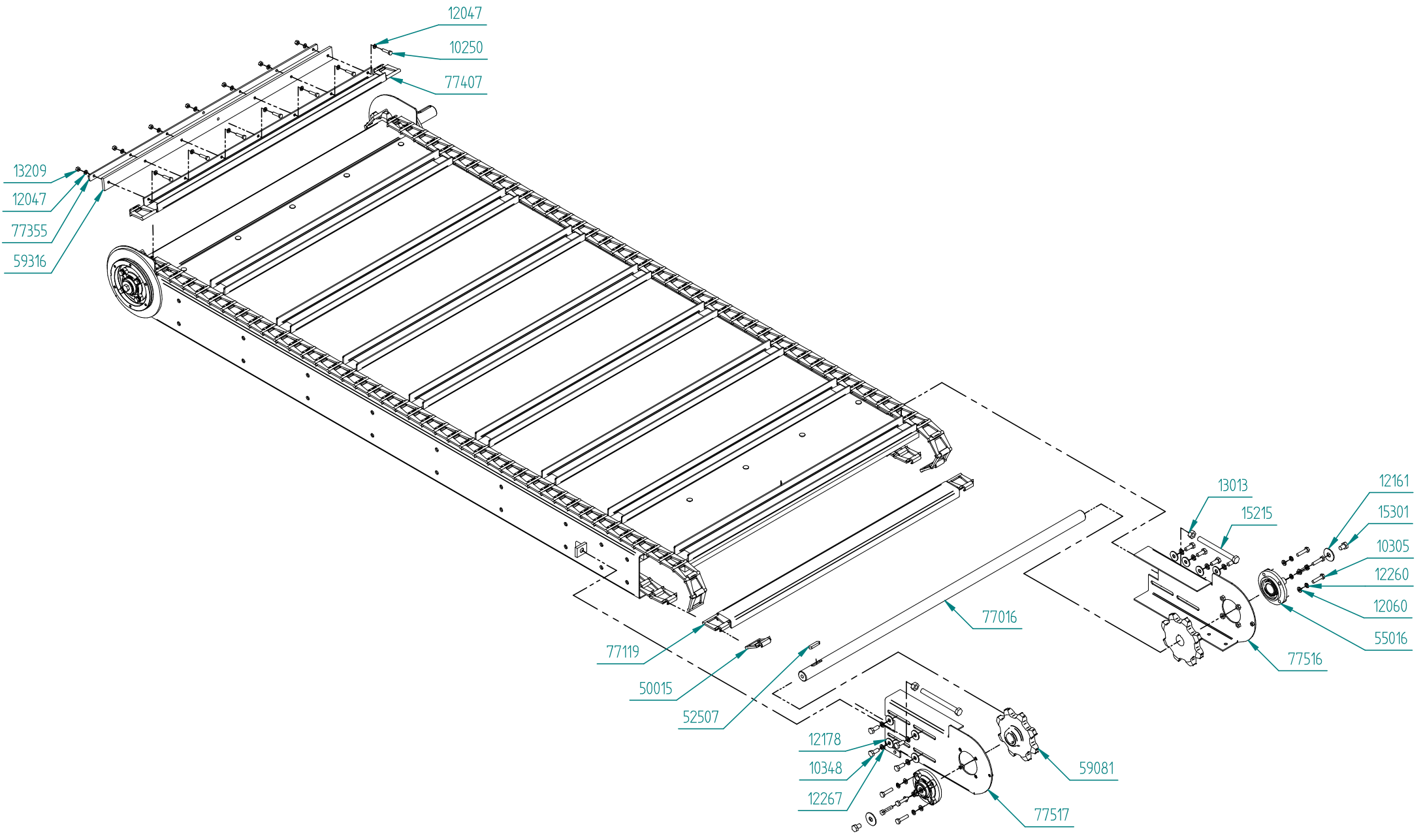

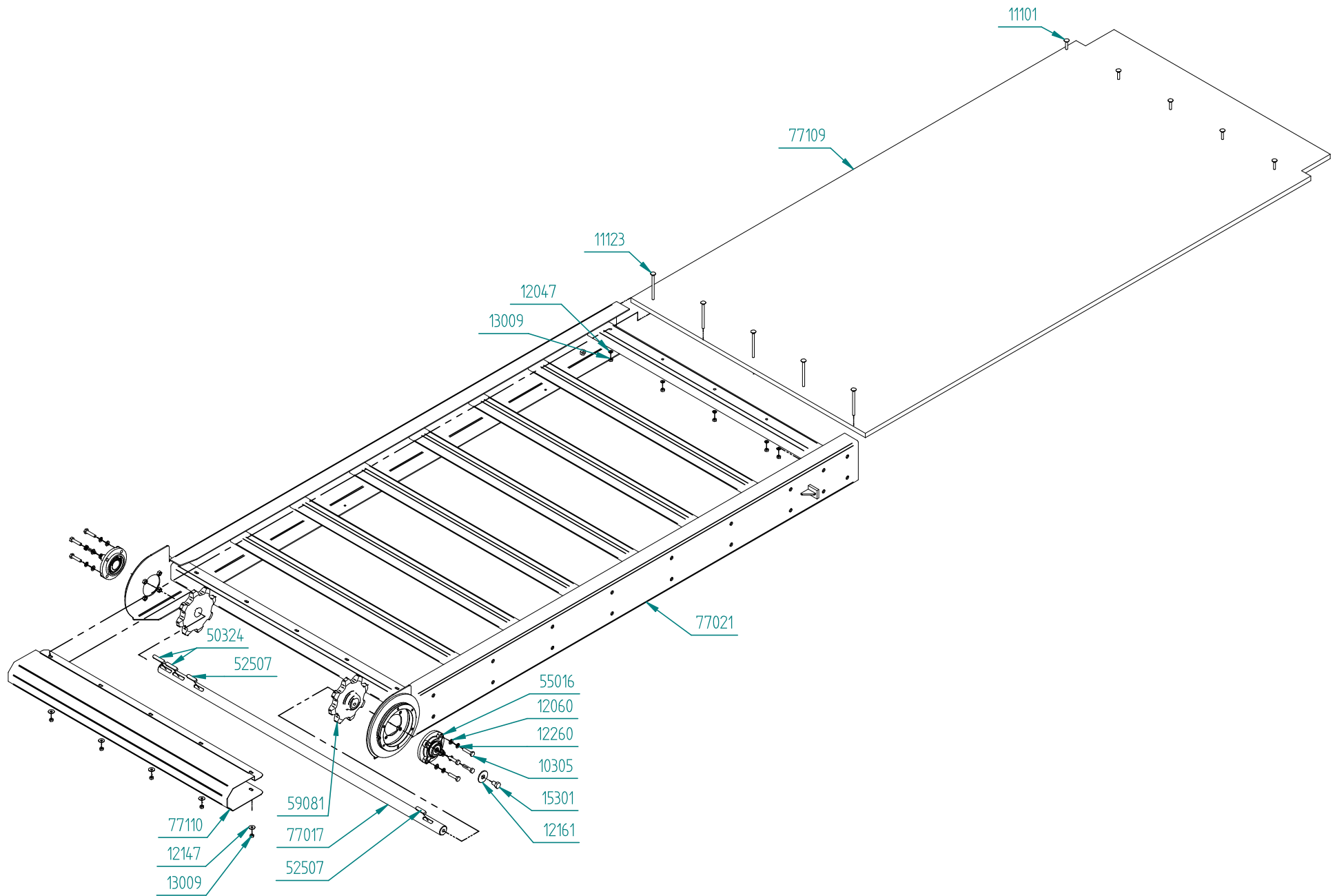

Part Number	Qty.	Title
10213	12	Bolt M6x40
10244	12	Bolt M8x20
10246	2	Bolt M8x25
10248	7	Bolt M8x30
10250	7	Bolt M8x35
10297	88	Bolt M10x25
10299	2	Bolt M10x30
10303	8	Bolt M10x40
10305	16	Bolt M10x45
10348	20	Bolt M12x30
10352	18	Bolt M12x40
10362	5	Bolt M12x75
10367	1	Bolt M12x120
11101	5	Lock head bolt M8x40
11123	5	Lock head bolt M8x120
12036	12	Washer M6
12047	35	Washer M8
12060	184	Washer M10
12067	47	Washer M12
12078	4	Washer M16
12147	9	Washer $\varnothing 24/8,4 \times 2$
12161	4	Washer $\varnothing 50/17 \times 3$
12178	8	Washer $\varnothing 37/13 \times 3$
12186	18	Washer $\varnothing 30/11 \times 2,5$

Part Number	Qty.	Title
12236	12	Spring washer M6
12247	16	Spring washer M8
12260	16	Spring washer M10
12267	36	Spring washer M12
13009	27	Nut M8
13013	4	Nut M16
13209	9	Lock nut M8
13210	90	Lock nut M10
13211	10	Lock nut M12
13213	2	Lock nut M16
13478	4	Wing nut M10
14001	2	Grease nipple 1/8" R
14302	1	Ear pin M6
15052	4	Hairpin M2,5
15215	2	Bolt M16x180, threaded to head
15301	4	Bolt M14x20
15505	2	Circlip A30x1,5
15934	12	Tube clamp, plastic
15936	6	Top plate for plastic tube clamp
16236	1	Sticker, left
16237	1	Sticker, right
16503	4	Bolt M8x20, black
35618	1	Warning triangle, large
50015	142	Chain link Kohlswa Ewart 78

Part Number	Qty.	Title
50324	2	Key 12x8x60
52507	3	Key 12x8x50
55016	4	Bearing UCFCX08
59054	1	Motor BG100 NC25
59081	4	Sprocket
59086	1	Gir RT 200
59223	2	Elbow
59316	1	Rubber list
59320	2	Transition
59340	4	S-hook 3 mm
74732	2	Locking washer for hinge
77016	1	Shaft, tightening side
77017	1	Driveshaft
77021	1	Bottom frame
77037	2	Side cover support, complete
77063	1	Spilltray
77070	1	End cover, lower
77071	1	Side cover, lower right
77072	1	Side cover, lower left
77073	1	Side cover, upper right
77074	1	Side cover, upper left
77075	1	End cover, upper
77100	3	Hinge, right
77101	3	Hinge, left

Part Number	Qty.	Title
77105	2	U-profile 2, cover
77106	4	U-profile 1, cover
77107	1	End cover, upper left
77108	1	End cover, upper right
77109	1	Visaform plate, upper
77110	1	Winding protection
77114	1	Cylinder bracket, right
77115	1	Cylinder bracket, left
77116	1	Gear bracket
77118	2	Hinge plate
77119	17	Carrier
77130	1	Cover lock
77152	4	Cover support, upper
77153	4	Cover support, lower
77164	1	Cover lock bracket
77189	1	Visaform plate, lower
77216	1	Middle cover, left bottom
77217	1	Middle cover, right bottom
77245	1	Hinge, front, right
77246	1	Hinge, front, left
77355	1	Clamp strip, carrier
77407	1	Carrier with holes for scraper
77516	1	Tightener, right bottom
77517	1	Tightener, left bottom

Part Number	Qty.	Title
77621	1	Bracket, left telescopic leg
77622	1	Bracket, right telescopic leg
77623	2	Fastener, telescopic leg
79019	2	Foot plate, telescopic legs
79385	4	Chain 3mm
80912	4	Flange
80913	2	Seeger ring J65
80924	2	Nipple
80925	4	O-ring
80946	1	Seal kit

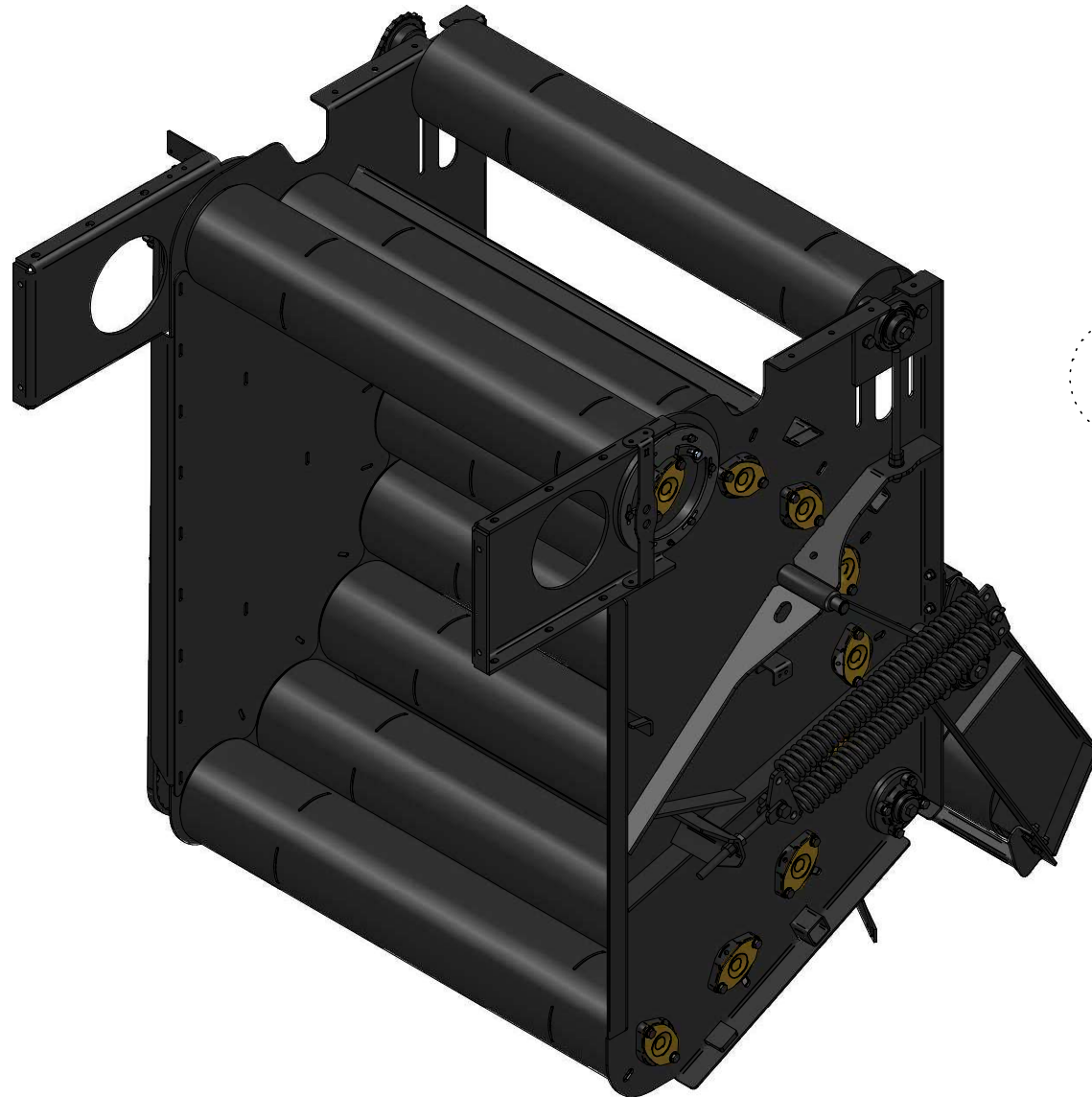

78412

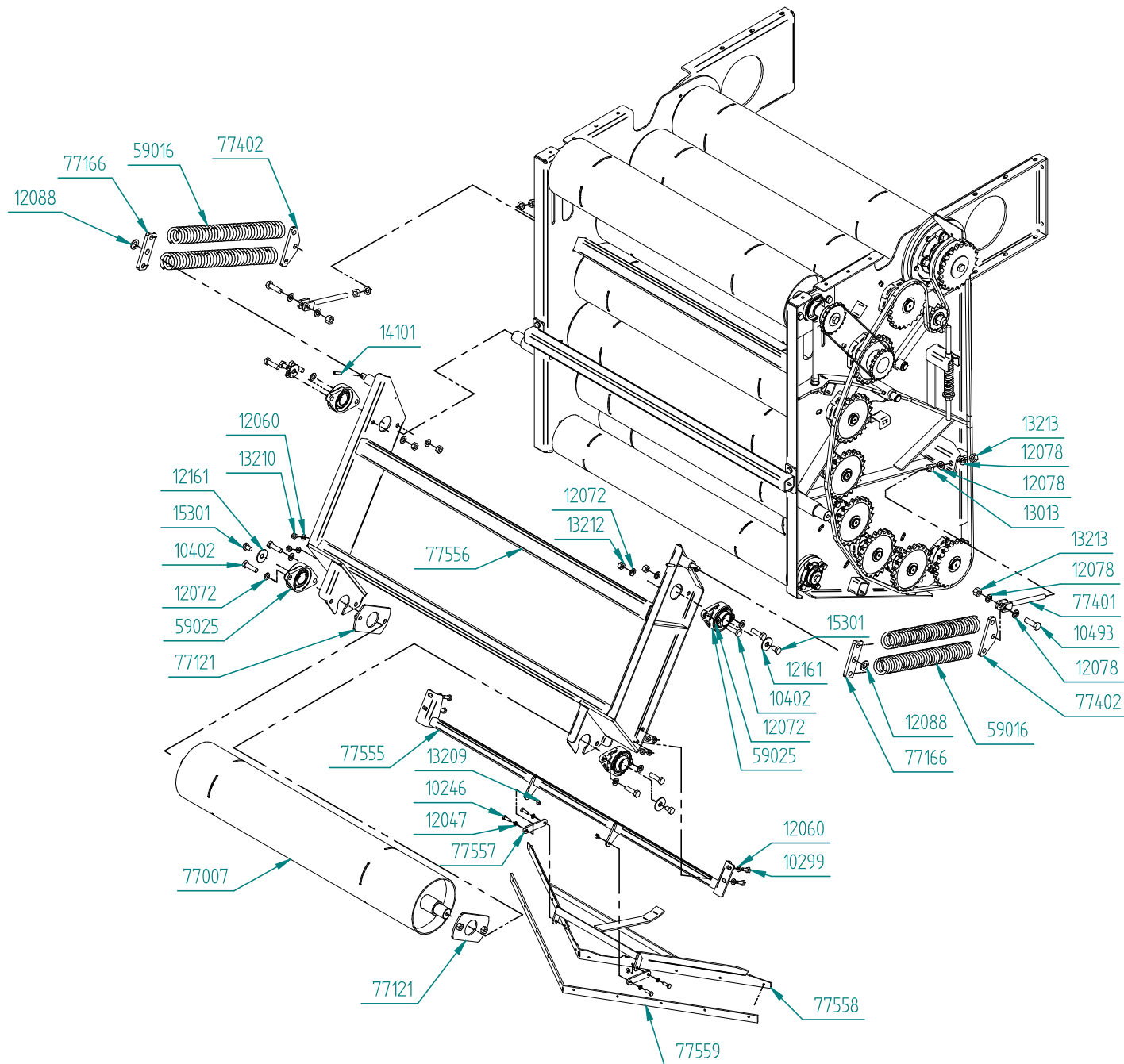

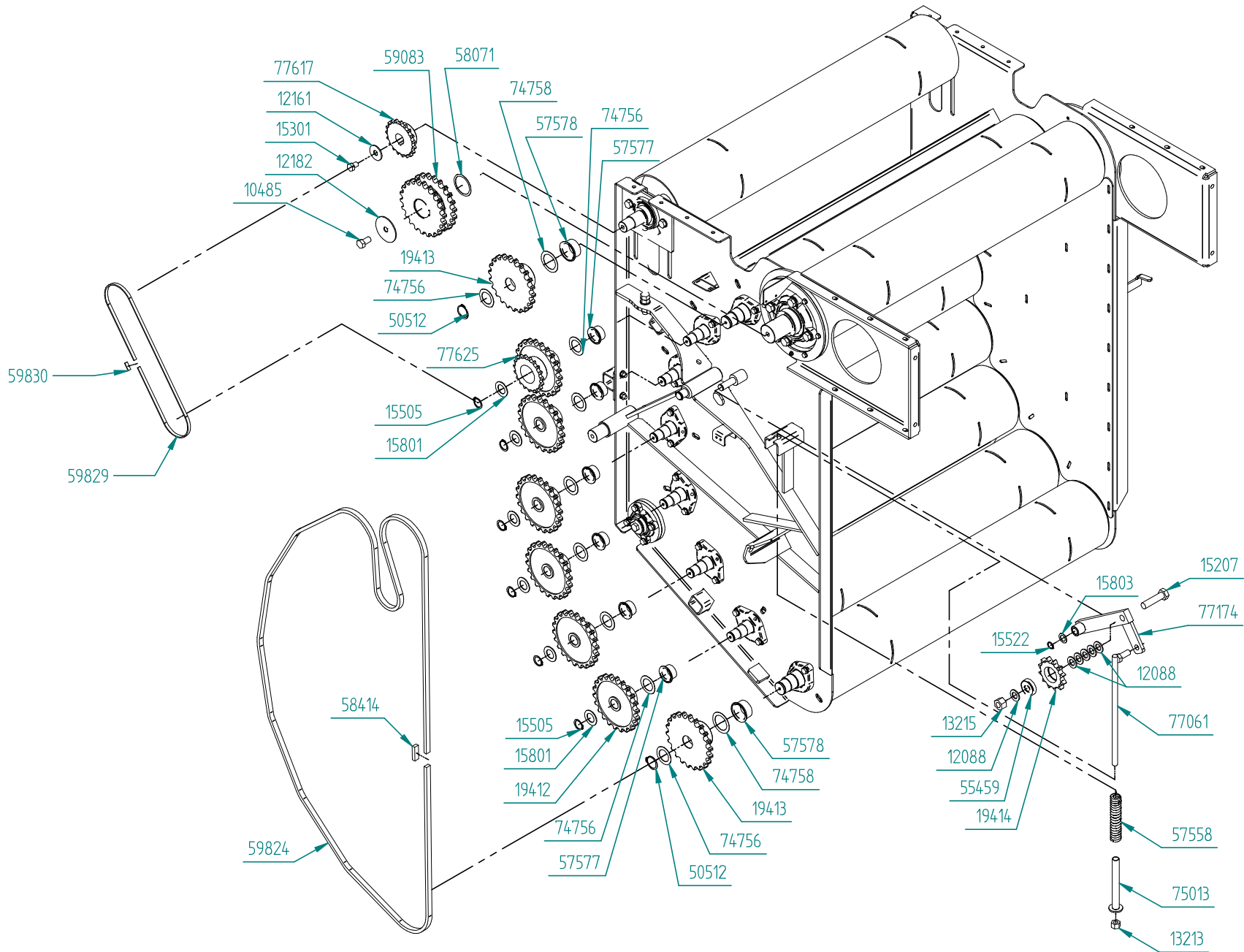

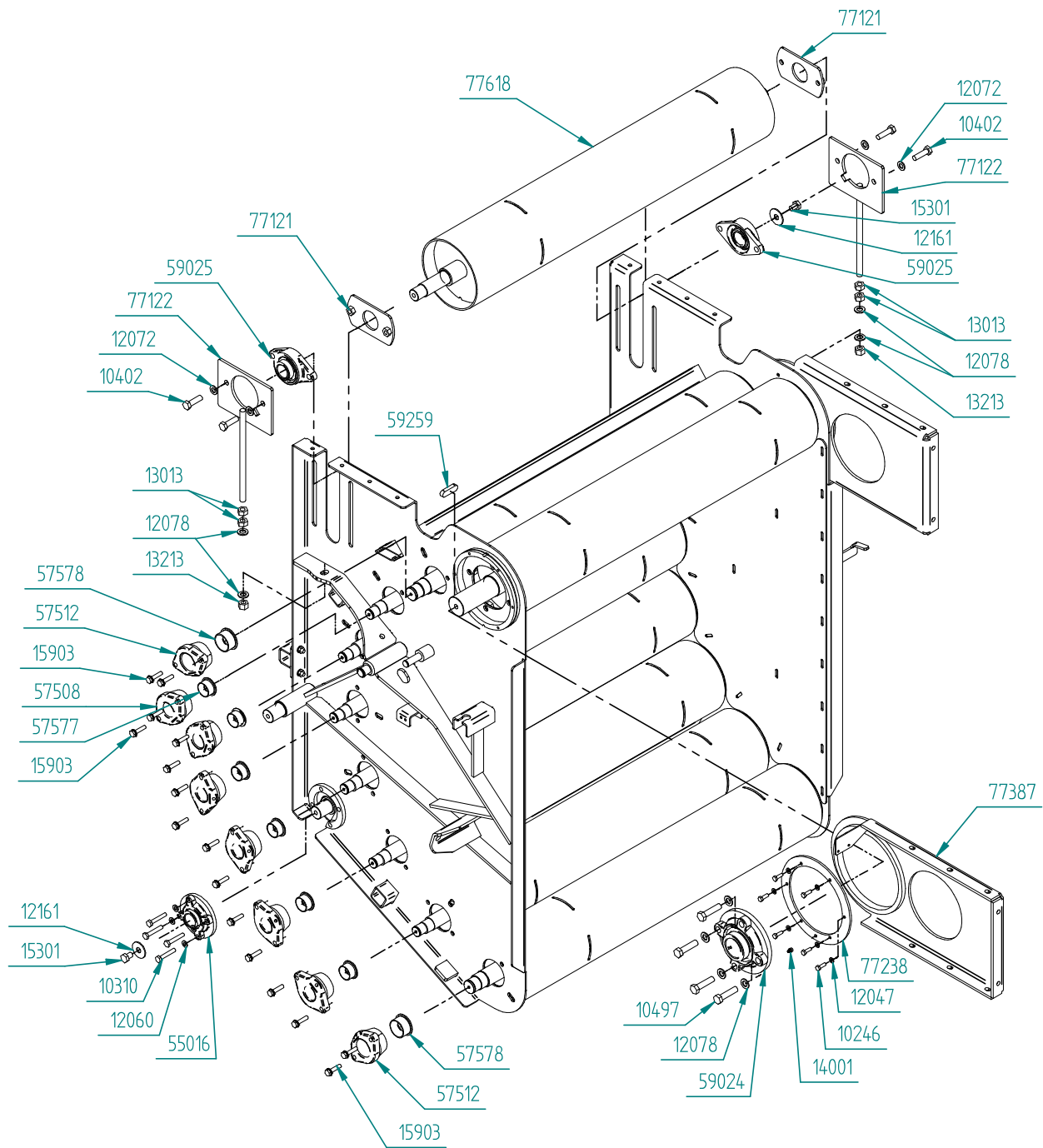

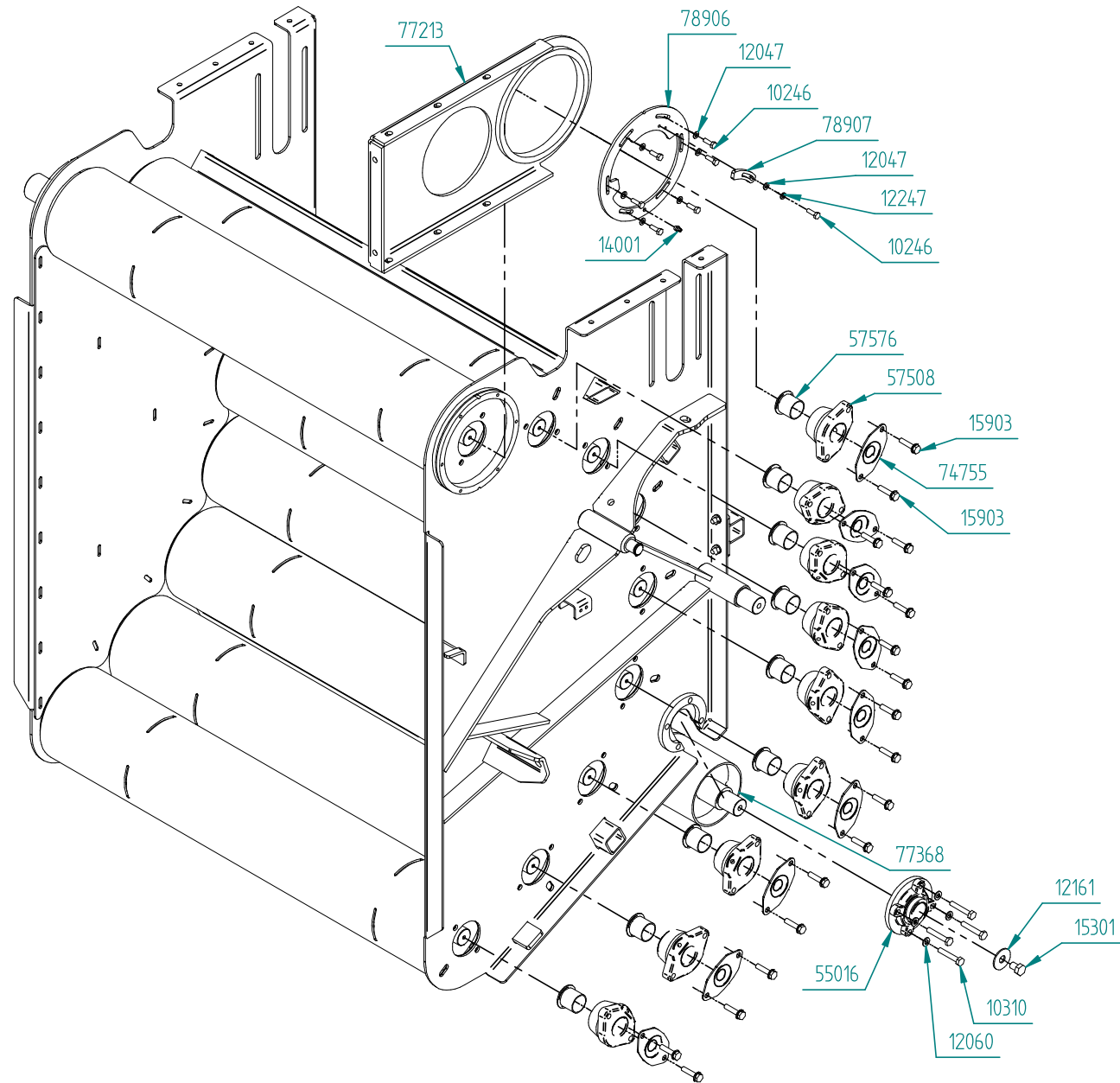

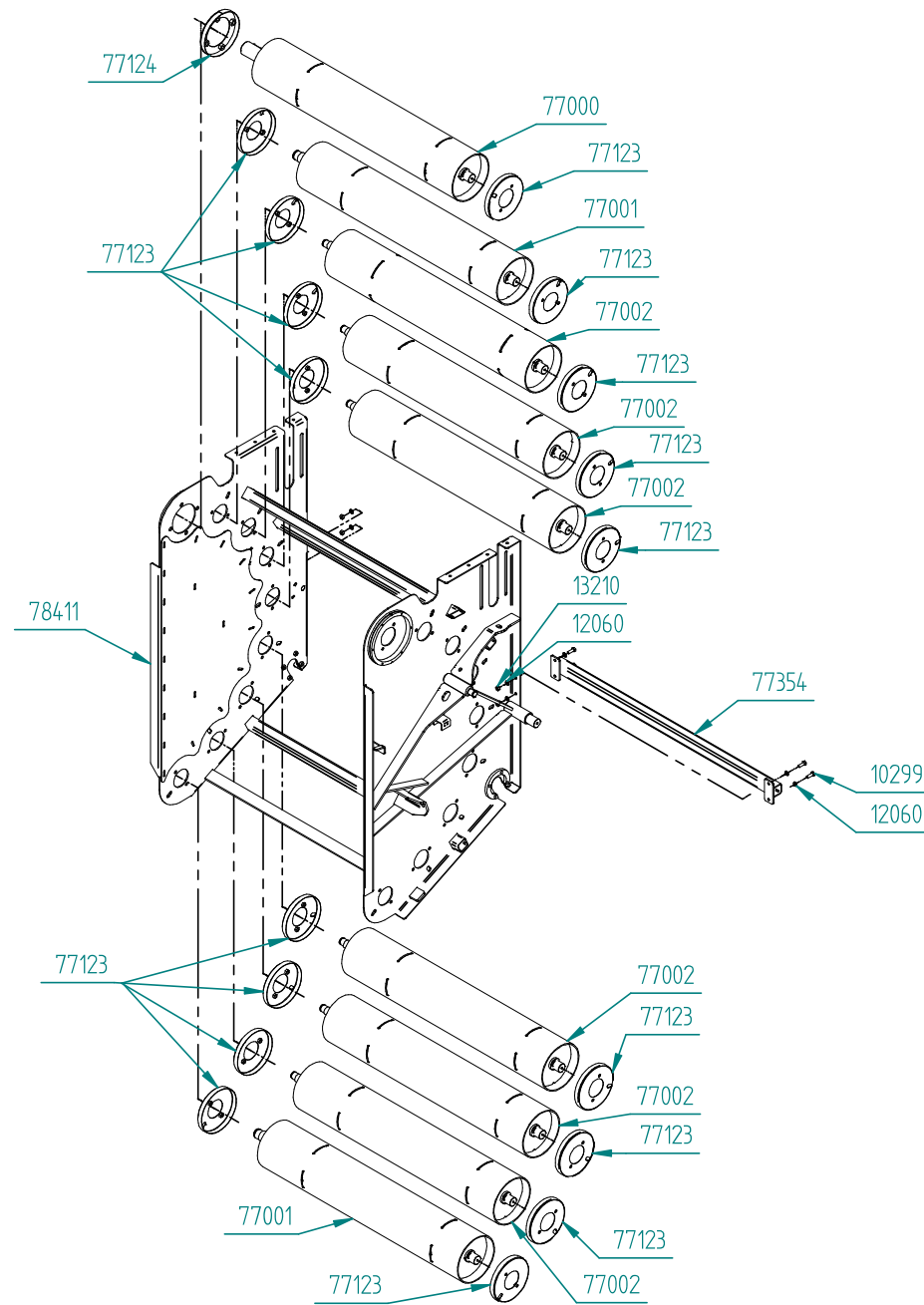

Part Number	Qty.	Title
10246	28	Bolt M8x25
10299	8	Bolt M10x30
10310	8	Bolt M10x60
10402	12	Bolt M14x50
10485	1	Bolt M16x30, threaded to head
10493	2	Bolt M16x50
10497	7	Bolt M16x65
12047	28	Washer M8
12060	24	Washer M10
12072	27	Washer M14
12078	19	Washer M16
12088	9	Washer M20
12161	8	Washer ϕ 50/17x3
12182	1	Washer ϕ 85/17x3
12247	1	Spring washer M8
13013	6	Nut M16
13209	4	Lock nut M8
13210	8	Lock nut M10
13212	4	Lock nut M14
13213	7	Lock nut M16
13215	1	Lock nut M20
14001	2	Grease nipple 1/8" R
14101	2	Splint ϕ 8x40
15207	1	Bolt M20x80, threaded to head

Part Number	Qty.	Title
15301	8	Bolt M14x20
15501	2	Circlip A25x1,2
15505	6	Circlip A30x1,5
15522	1	Circlip A20x1,75
15801	6	Washer ϕ 50/30x2
15803	1	Washer ϕ 20/32x1
15903	34	Bolt M10x45
19412	5	Sprocket
19413	2	Sprocket
19414	1	Sprocket
50512	2	Circlip A40x1,75
55016	2	Bearing UCFCX08
55459	1	Bearing 6304 2RS
57508	15	Bearing housing ϕ 44 invv.
57512	2	Bearing housing ϕ 55 invv.
57558	1	Spring, chain tightener
57576	9	Plain bearing ϕ 40/44x55x40
57577	12	Plain bearing ϕ 40/44x55x25
57578	4	Plain bearing ϕ 50/55x65x30
58071	1	Shims
58414	1	Chain lock 1"
59016	4	Spring
59024	1	Bearing UCFC212
59025	6	Bearing UCFL208

Part Number	Qty.	Title
59083	1	Flexible coupling, inner sprocket, double
59259	1	Key 18x11x60
59824	1	Chain, chamber 1"
59829	1	Chain 3/4"
59830	1	Chain lock 3/4"
74755	9	Bearing housing cover
74756	8	Shim ϕ 60/40x1
74758	2	Washer ϕ 70/50x1
75013	1	Protection tube chain tightener
77000	1	Roller 16 and 17
77001	2	Roller 1, 7, 8 and 15
77002	6	Roller 1-4, 6, 9-14
77007	1	Tightening roller 1
77061	1	Chain tightener
77121	4	Nut plate, tightener front
77122	2	Tightening mechanism
77123	17	Winding protection
77124	1	Winding protection 2
77166	2	Spring fastener, belt tightener
77174	1	Chain tightener, front
77213	1	Hinge plate right
77238	1	Locking hinge ring
77354	1	Stiffening tube
77368	1	Tightening roller, small dia.

Part Number	Qty.	Title
77387	1	Hinge plate left
77401	2	Tightening rod, springs, belt tightener
77402	2	Chain link, spring fastener
77555	1	Scraper suspension, front
77556	1	Belt tightener, front
77557	2	Scraper link
77558	1	Scraper, front
77559	1	Scraper plastic, front
77617	1	Sprocket
77618	1	Tightening roller 1 with drive
77625	1	Sprocket, double drive, tightening roller
78411	1	Weldment parts, front chamber, industrial
78906	1	Segment for chamber sensor
78907	1	Bow, chamber sensor
79041	1	Sensor bracket chamber open

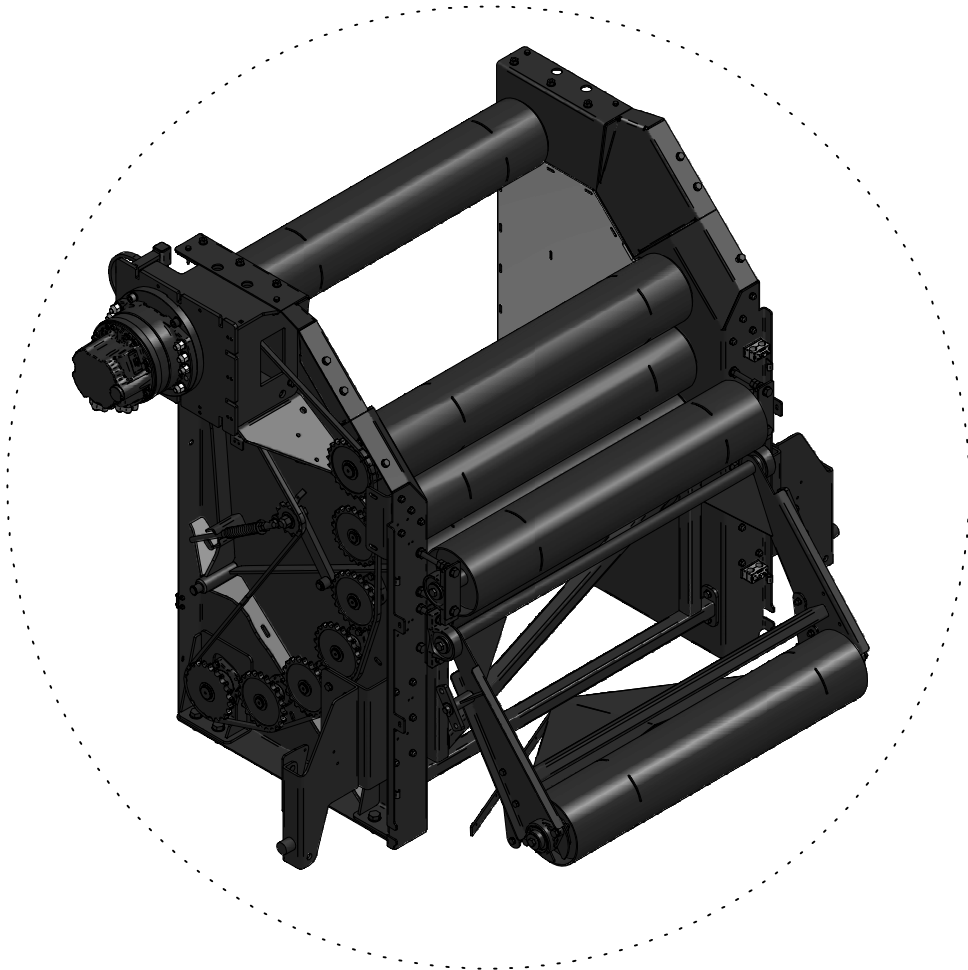

78859
Rear chamber with standard rollers

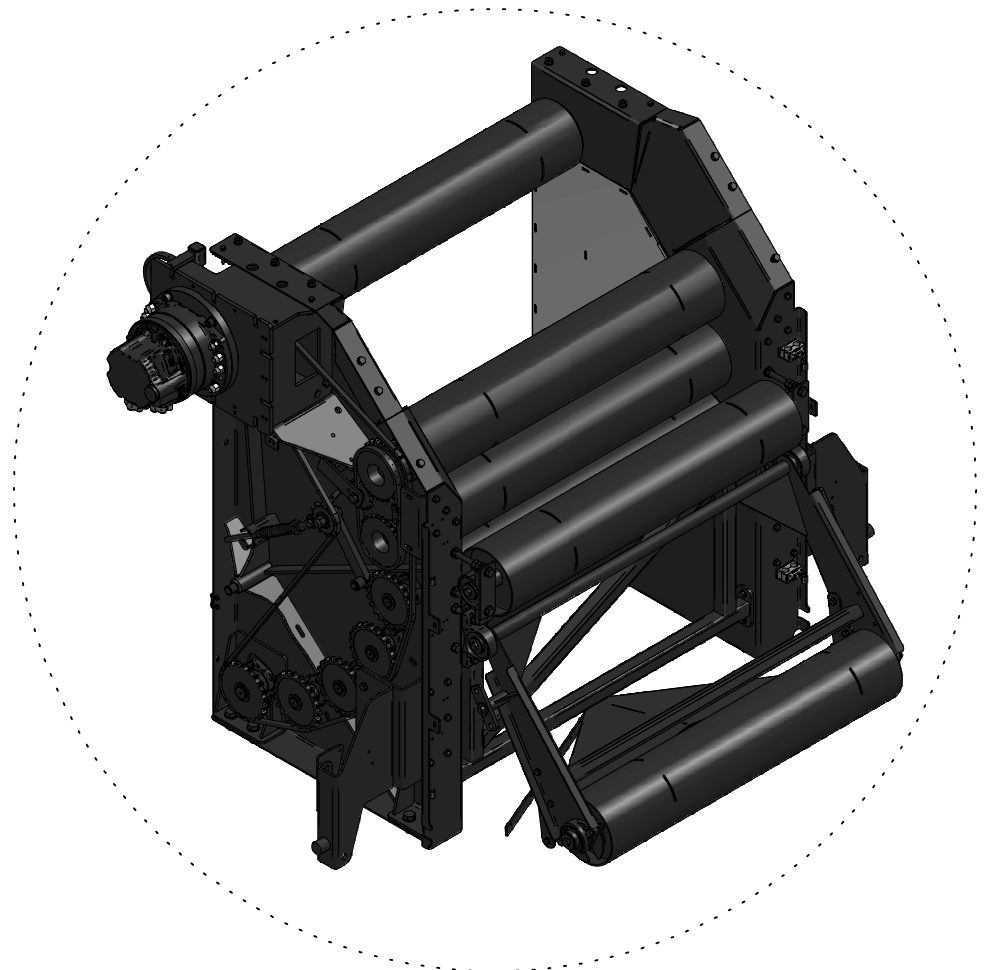

78969
Rear chamber with eccentric rollers

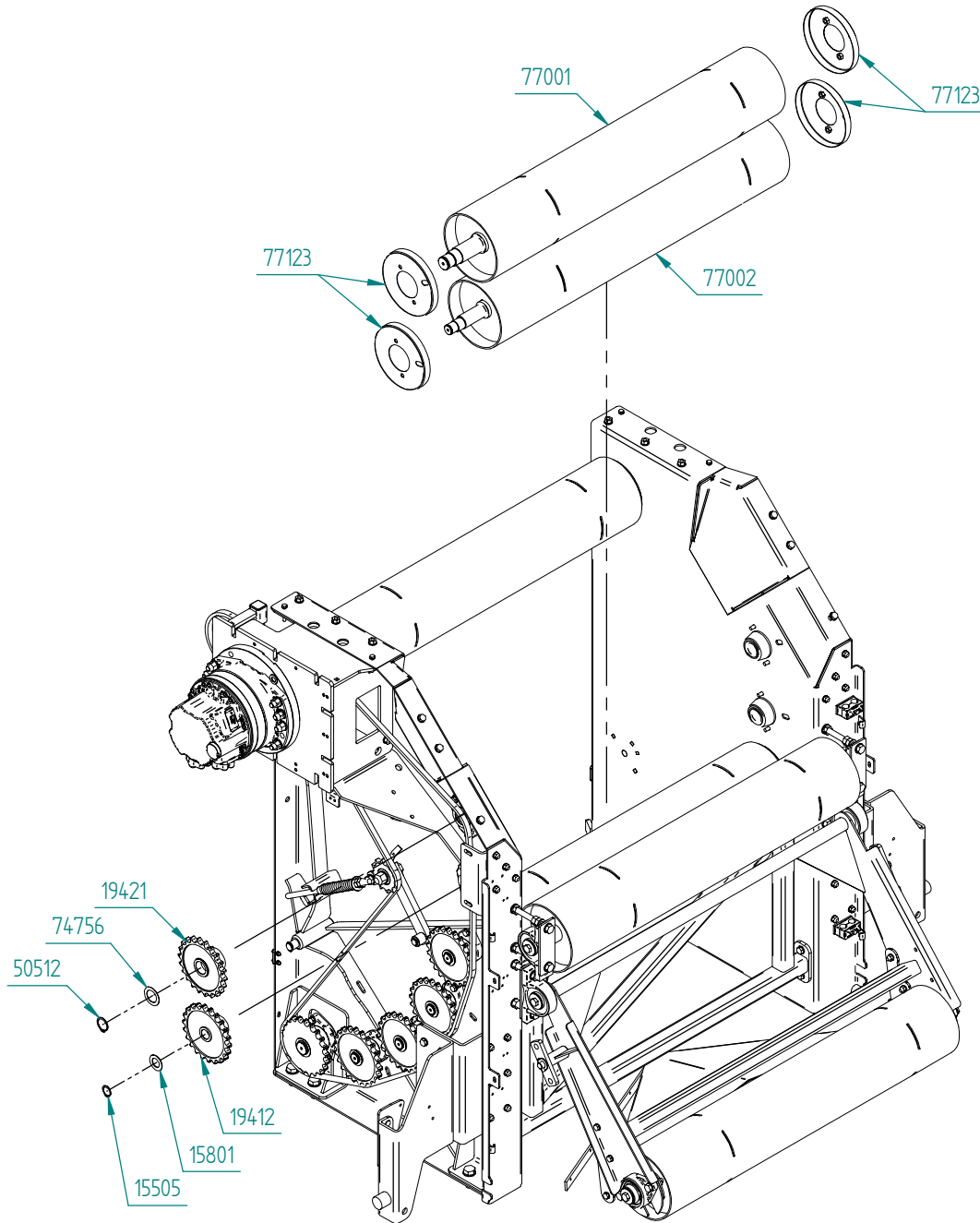

Standard rollers

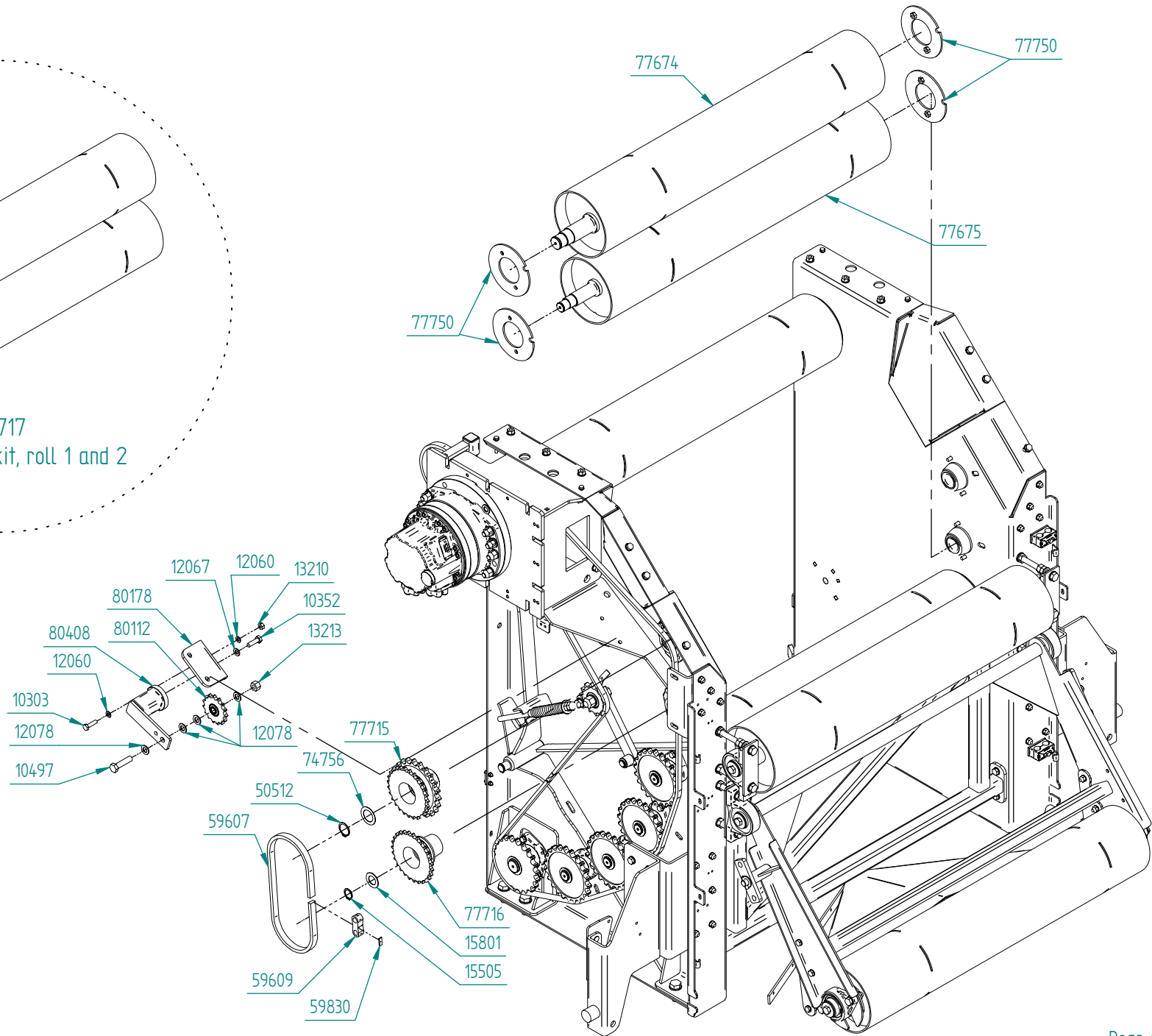
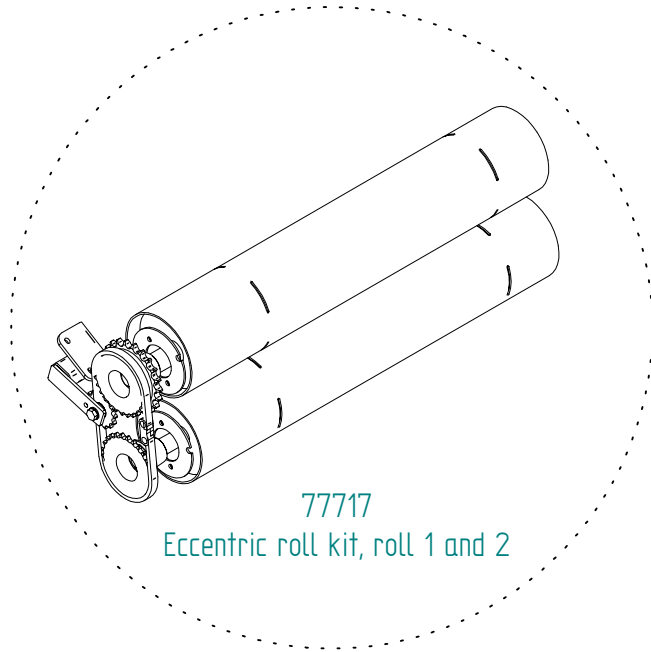

Common parts

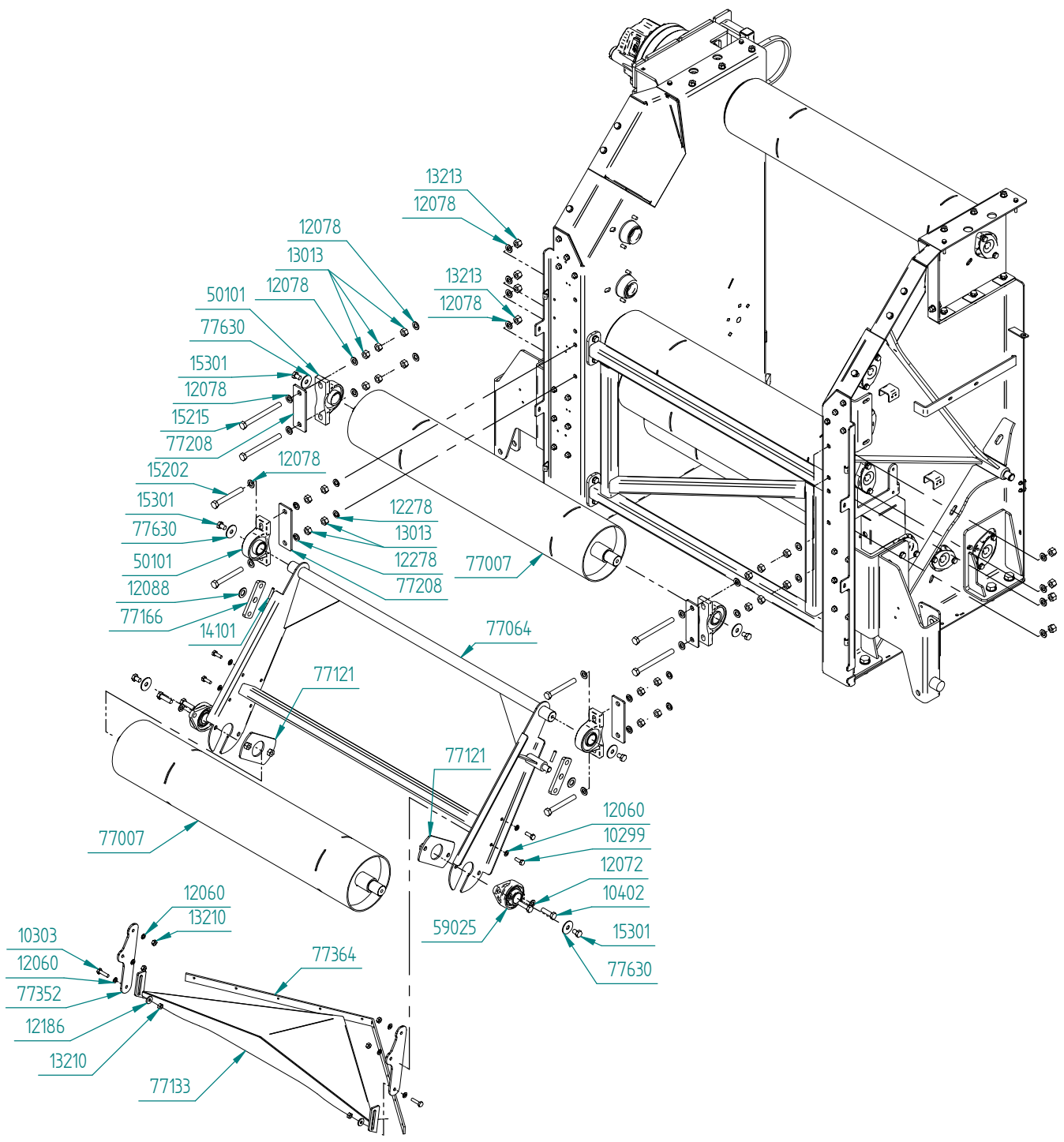

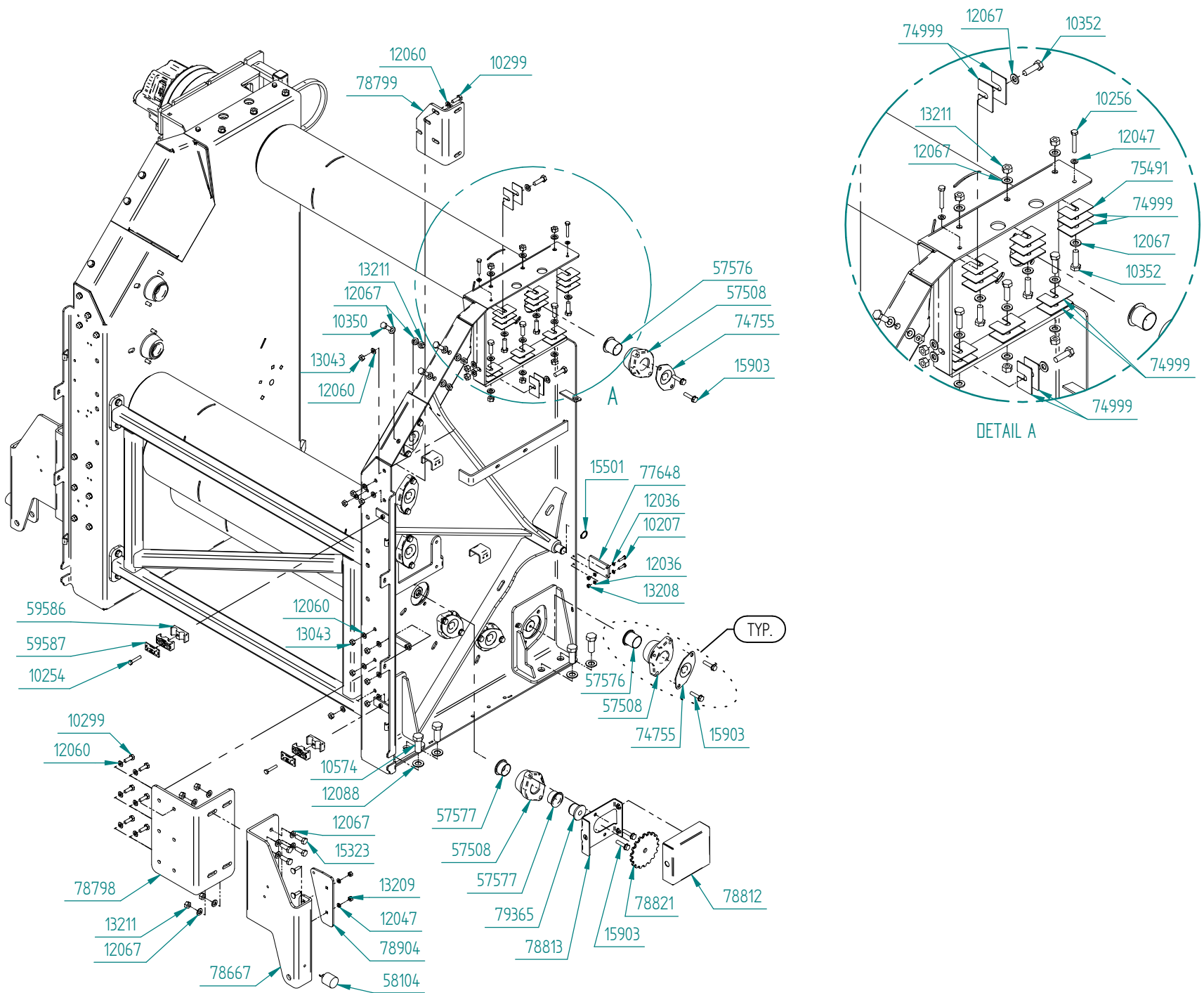

Common parts

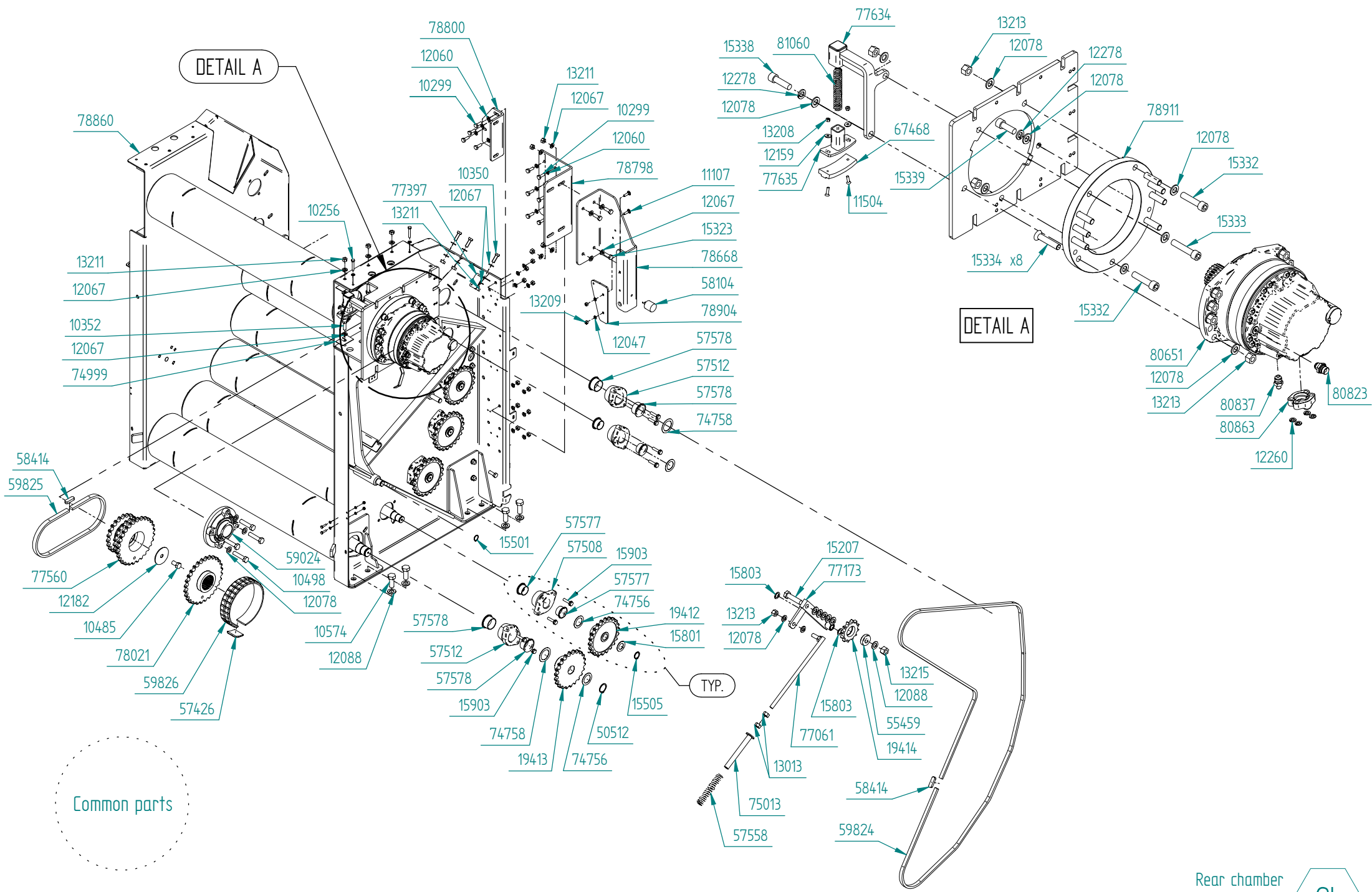

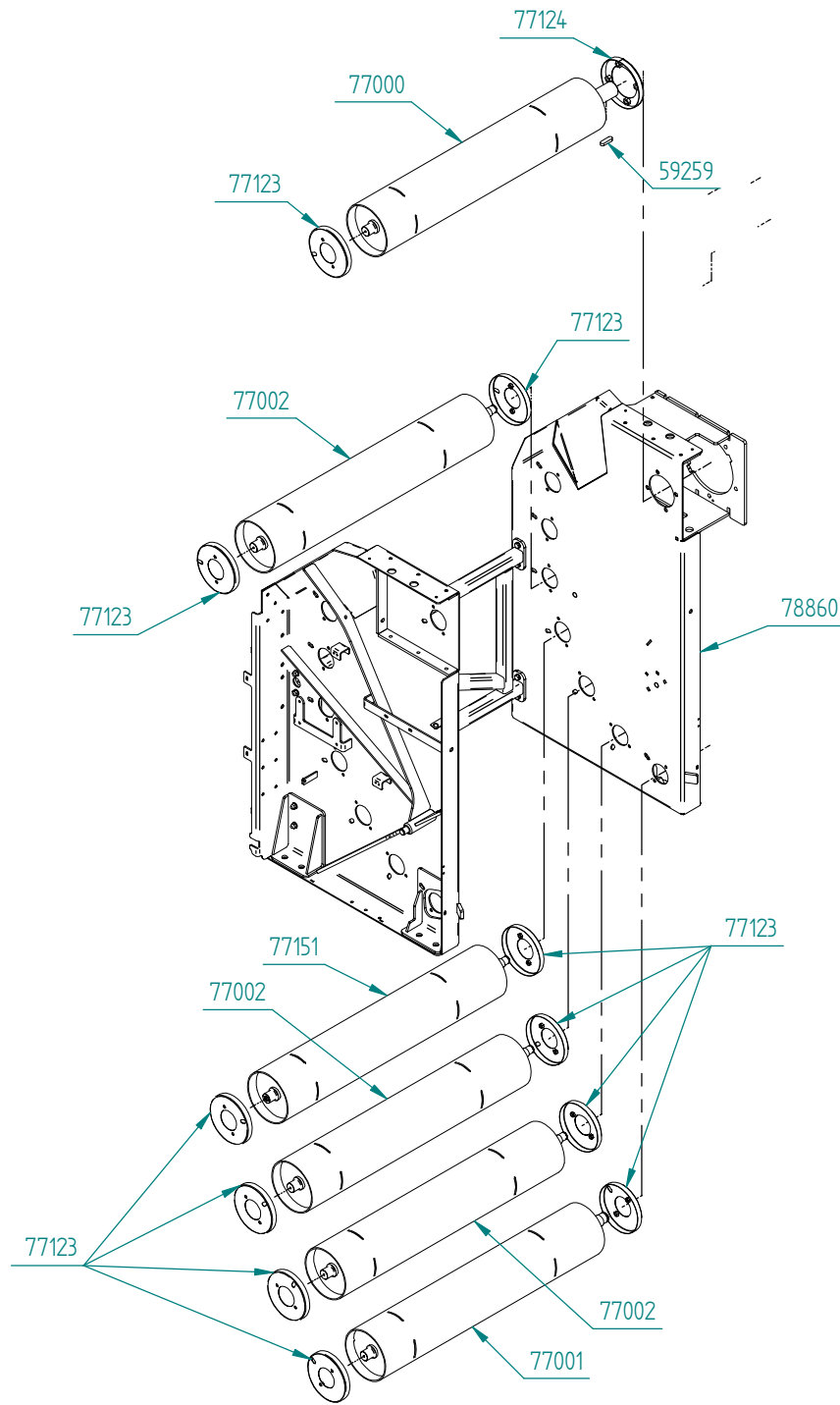

Common parts

Part Number	Qty.	Title
10207	4	Bolt M6x25, threaded to head
10254	2	Bolt M8x45
10256	4	Bolt M8x50
10299	24	Bolt M10x30
10303	4	Bolt M10x40
10350	6	Bolt M12x35
10352	32	Bolt M12x40
10402	4	Bolt M14x50
10485	1	Bolt M16x30, threaded to head
10497	4	Bolt M16x65
10498	4	Bolt M16x70
10499	2	Bolt M16x75
10574	8	Bolt M20x50
11107	4	Lock head bolt M8x30
11504	2	Countersunk bolt M6x20
12036	8	Washer M6
12047	8	Washer M8
12060	55	Washer M10
12067	91	Washer M12
12072	4	Washer M14
12078	52	Washer M16
12088	16	Washer M20
12159	2	Washer \varnothing 18/6,4
12182	1	Washer \varnothing 85/17x3

Part Number	Qty.	Title
12186	5	Washer \varnothing 30/11x2,5
12260	8	Spring washer M10
12278	8	Spring washer M16
13013	22	Nut M16
13043	20	Lock nut M10
13208	6	Lock nut M6
13209	4	Lock nut M8
13210	8	Lock nut M10
13211	45	Lock nut M12
13213	23	Lock nut M16
13215	1	Lock nut M20
14101	2	Splint \varnothing 8x40
15202	4	Bolt M16x130, threaded to head
15207	1	Bolt M20x80, threaded to head
15215	4	Bolt M16x180, threaded to head
15301	6	Bolt M14x20
15323	8	Bolt M12x35
15334	8	Countersunk bolt M16x80
15501	2	Circlip A25x1,2
15505	6	Circlip A30x1,5
15522	1	Circlip A20x1,75
15801	6	Washer \varnothing 50/30x2
15803	2	Washer \varnothing 20/32x1
15903	30	Bolt M10x45

Part Number	Qty.	Title
19412	5	Sprocket
19413	1	Sprocket
19414	1	Sprocket
19421	1	Sprocket
50101	4	Bearing UCP208
50512	3	Circlip A40x1,75
55459	1	Bearing 6304 2RS
57426	1	Chain duplex, lock
57508	13	Bearing housing \varnothing 44 innv.
57512	2	Bearing housing \varnothing 55 innv.
57558	1	Spring, chain tightener
57576	7	Plain bearing \varnothing 40/44x55x40
57577	12	Plain bearing \varnothing 40/44x55x25
57578	4	Plain bearing \varnothing 50/55x65x30
58104	2	Rubber buffer, complete
58414	2	Chain lock 1"
59024	1	Bearing UCFC212
59025	2	Bearing UCFL208
59259	1	Key 18x11x60
59586	2	Pipe clamp double 22 mm
59587	2	Top plate for double clamp 20-25
59607	1	Chain, eccentric, 3/4"
59609	1	Chain half link 3/4"
59824	1	Chain, chamber 1"

Part Number	Qty.	Title
59825	1	Chain, between chambers 1"
59826	1	Chain duplex 1"
59830	1	Chain lock 3/4"
67468	1	Wearing plastic, chain tightener, short chain
74755	7	Bearing housing cover
74756	8	Shim ø60/40x1
74758	2	Washer ø70/50x1
74767	1	Endpiece for count bolt
74999	16	Shims 70x45x2
75013	1	Protection tube chain tightener
77000	1	Roller 16 and 17
77001	2	Roller 1, 7, 8 and 15
77002	4	Roller 1-4, 6, 9-14
77007	2	Tightening roller 1
77061	1	Chain tightener
77064	1	Belt tightener, rear
77121	2	Nut plate, tightener front
77123	15	Winding protection
77124	1	Winding protection 2
77133	1	Scraper plow, rear
77151	1	Roller 5
77166	2	Spring fastener, belt tightener
77173	1	Chain tightener, rear
77208	4	Feeding plate, tightening bearing

Part Number	Qty.	Title
77352	2	Scraper fastener, rear
77364	1	Wearing plastic, scraper, rear
77397	1	Bracket, chain lubrication
77560	1	Flexible coupling, inner
77565	1	Spring tightener, short chain
77630	6	Washer ø50/15x3
77634	1	Chain tightener, short chain
77635	1	Chain tightener, glider
77648	2	Shims, chamber opening, 6mm
77674	1	Roller 1, eccentric
77675	1	Roller 2, eccentric
77715	1	Sprocket, eccentric roller 1
77716	1	Sprocket, eccentric roller 2
77750	4	Nut plate, eccentric roller
78021	1	Flexible coupling, outer part
78667	1	Film storage mount, right rear
78668	1	Film storage mount, left rear
78798	2	Plastic storage, bracket
78799	1	Bracket, side cover, right
78800	1	Bracket, side cover, right
78812	1	Counting wheel cover
78813	1	Sensor mount
78821	1	Counting wheel, chamber
78860	1	Rear chamber, weldment parts

Part Number	Qty.	Title
78904	2	Gas spring bracket RB LF LB
78905	1	Bracket for sensor, end dampening
78911	1	Adaptor for chamber motor
80112	1	Sprocket
80178	1	Chain tensioner mount
80408	1	Chain tightener SE27, modified
80651	1	Chamber motor, High flow
80823	1	Fitting 1/4"-1/4"
80837	1	Fitting 1/4"-1/4"
80863	2	SAE-flange 3/4" 6000 psi



77316

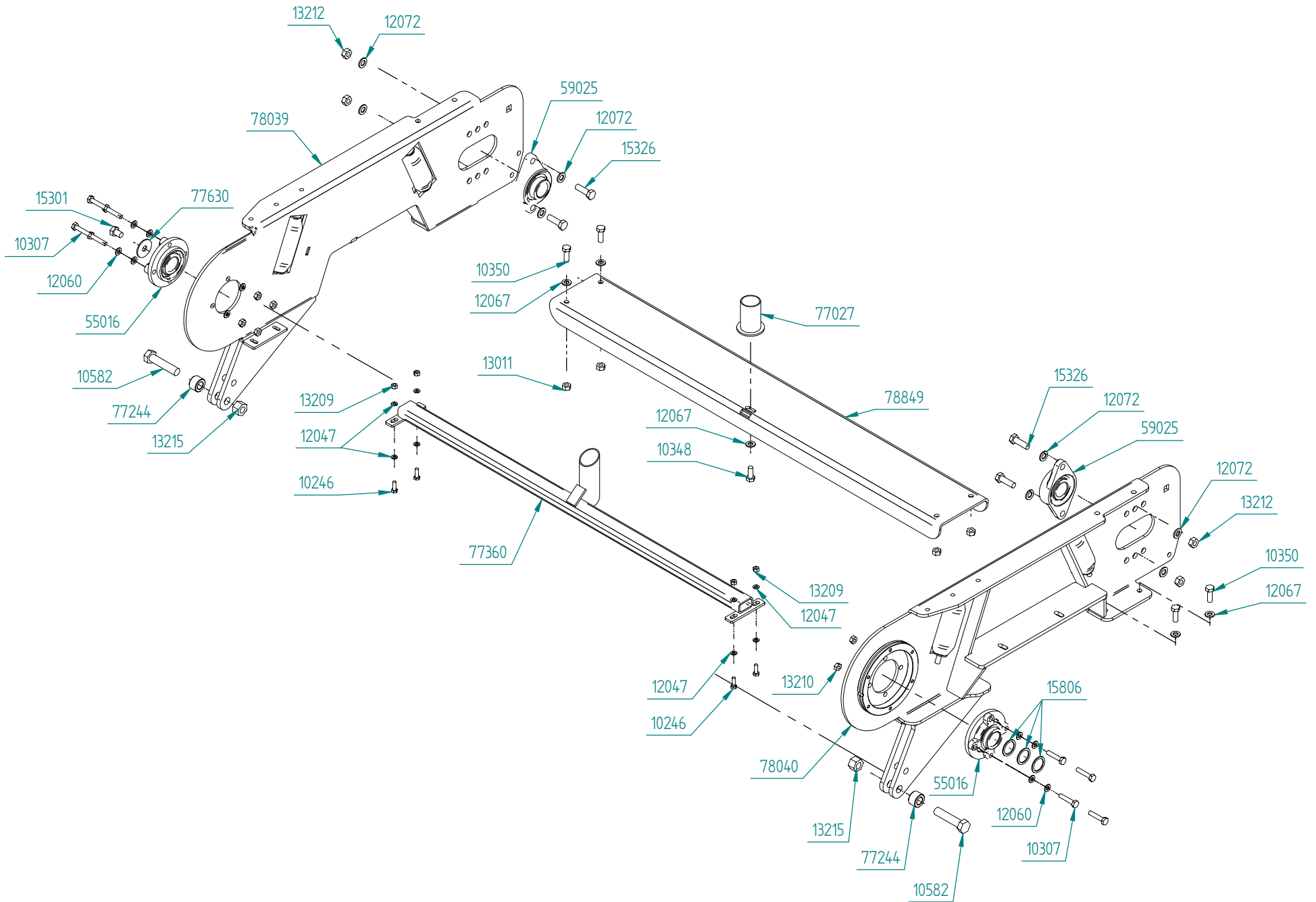

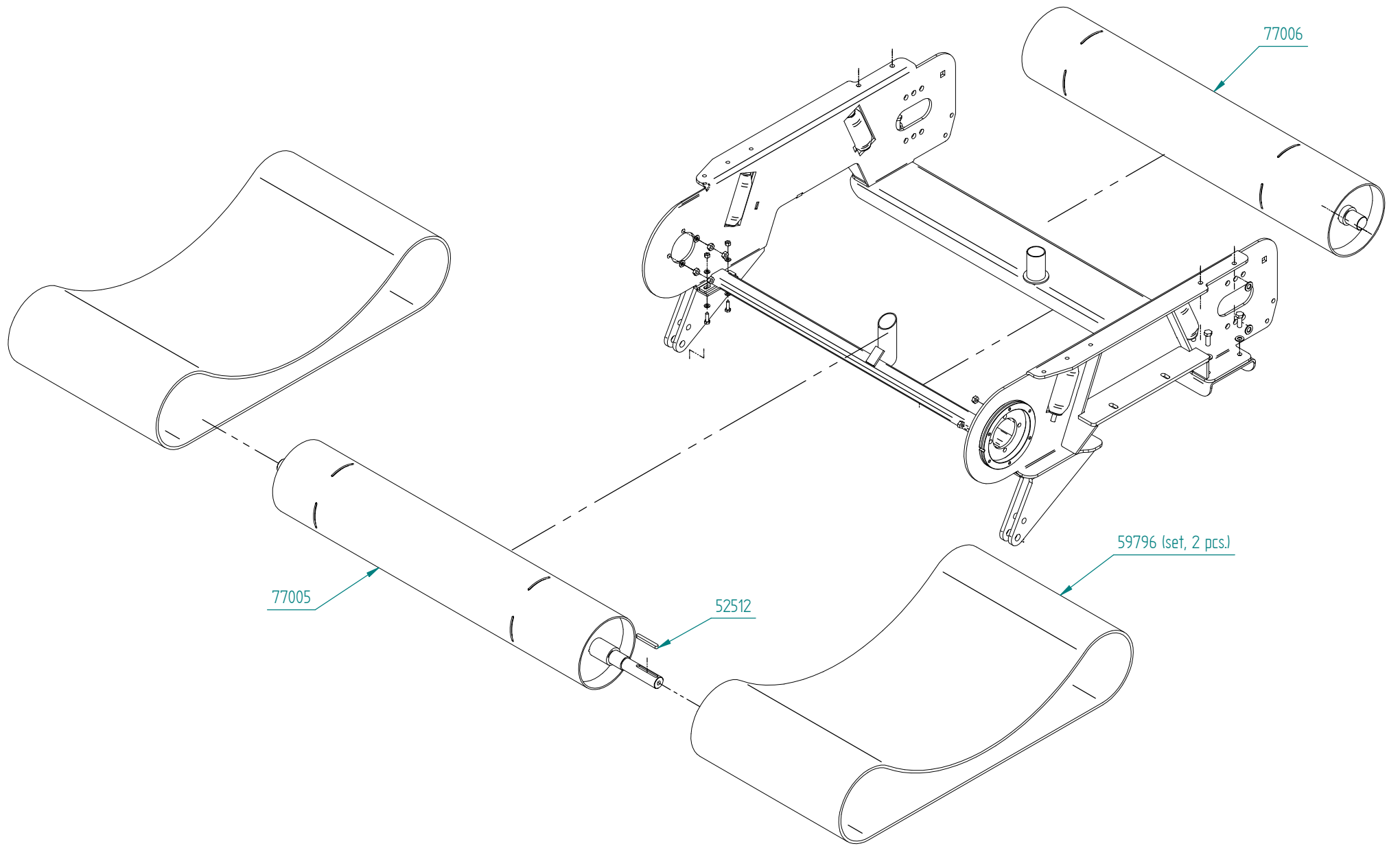

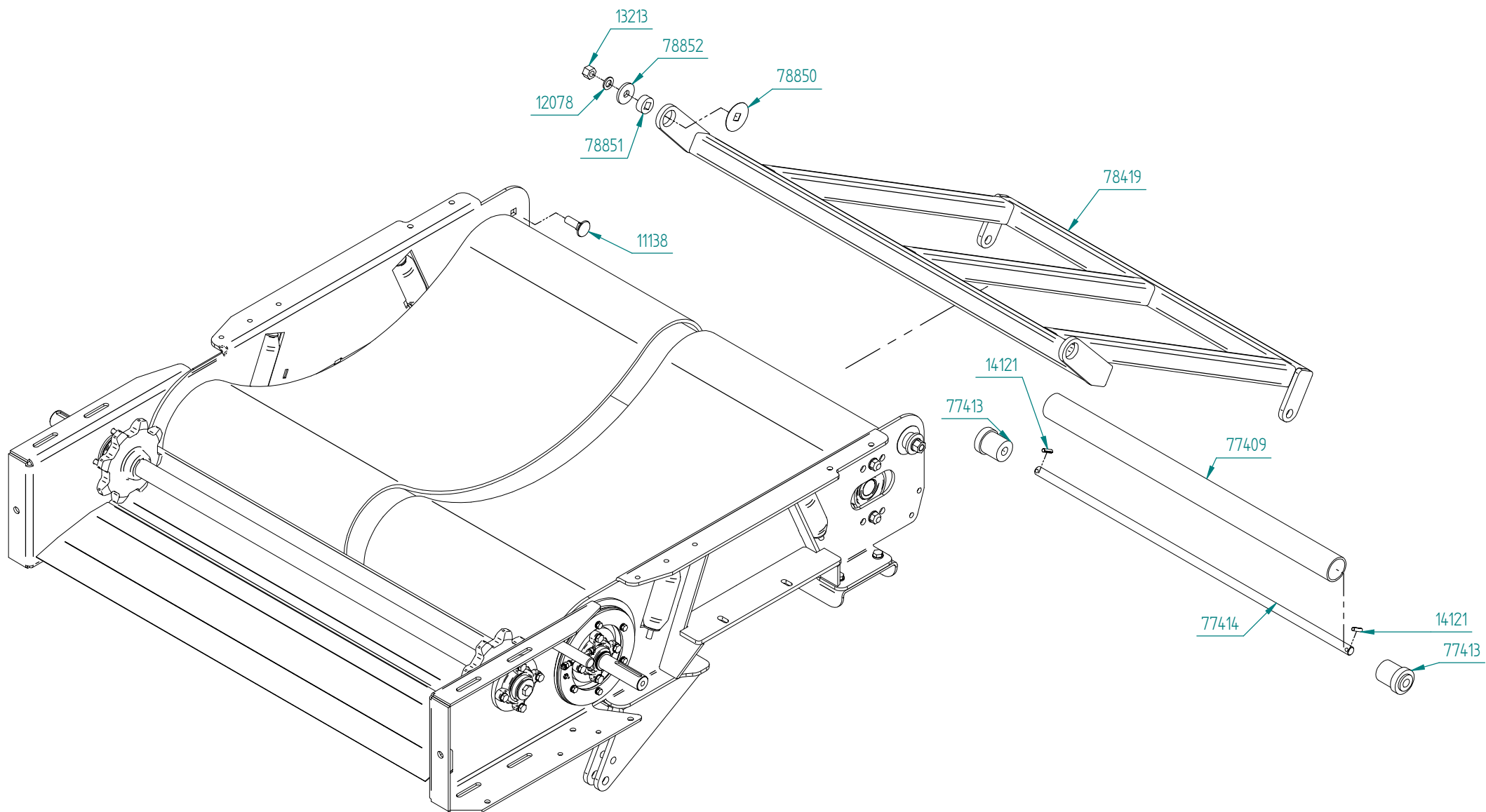

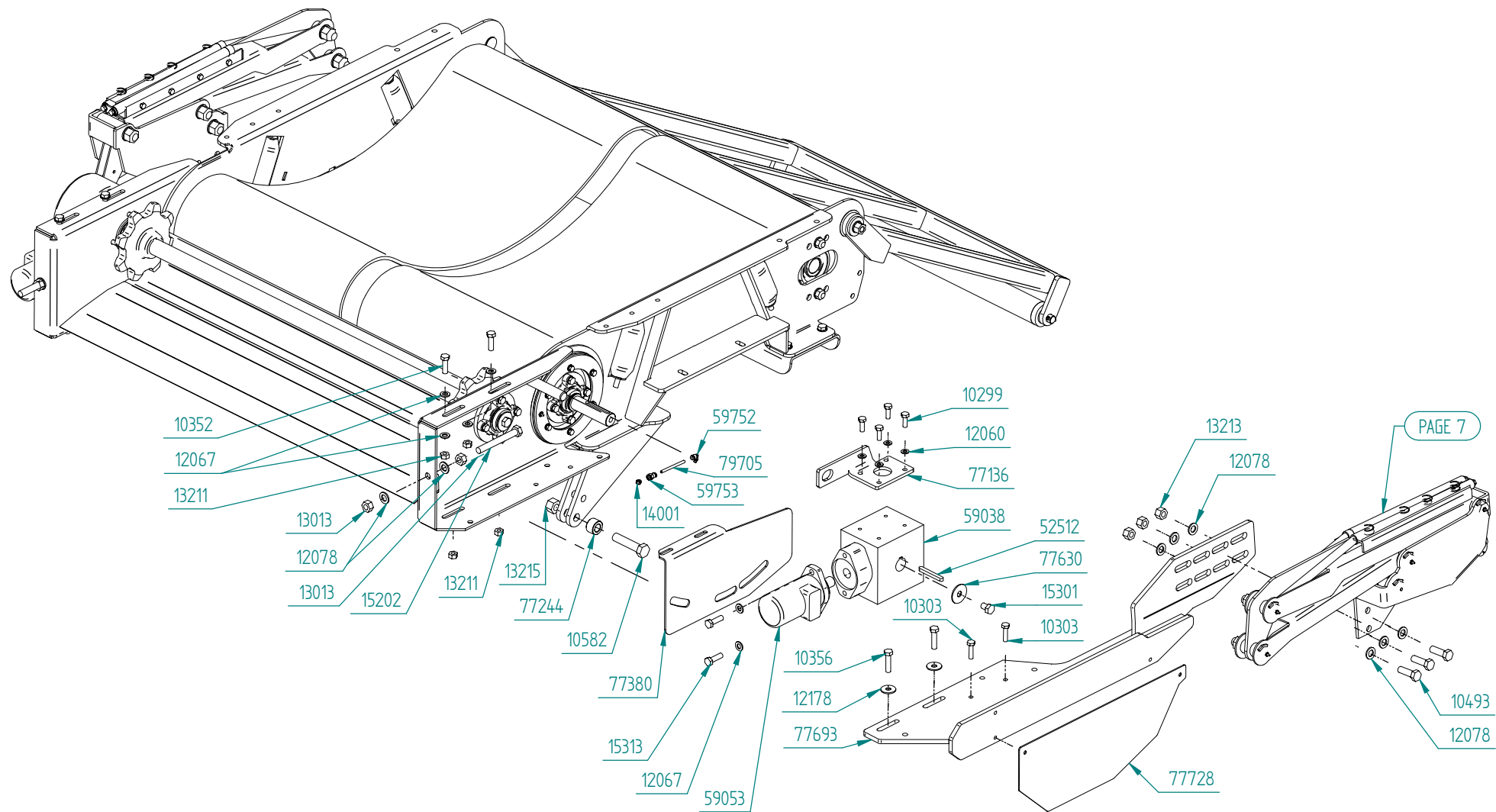

PAGE 7

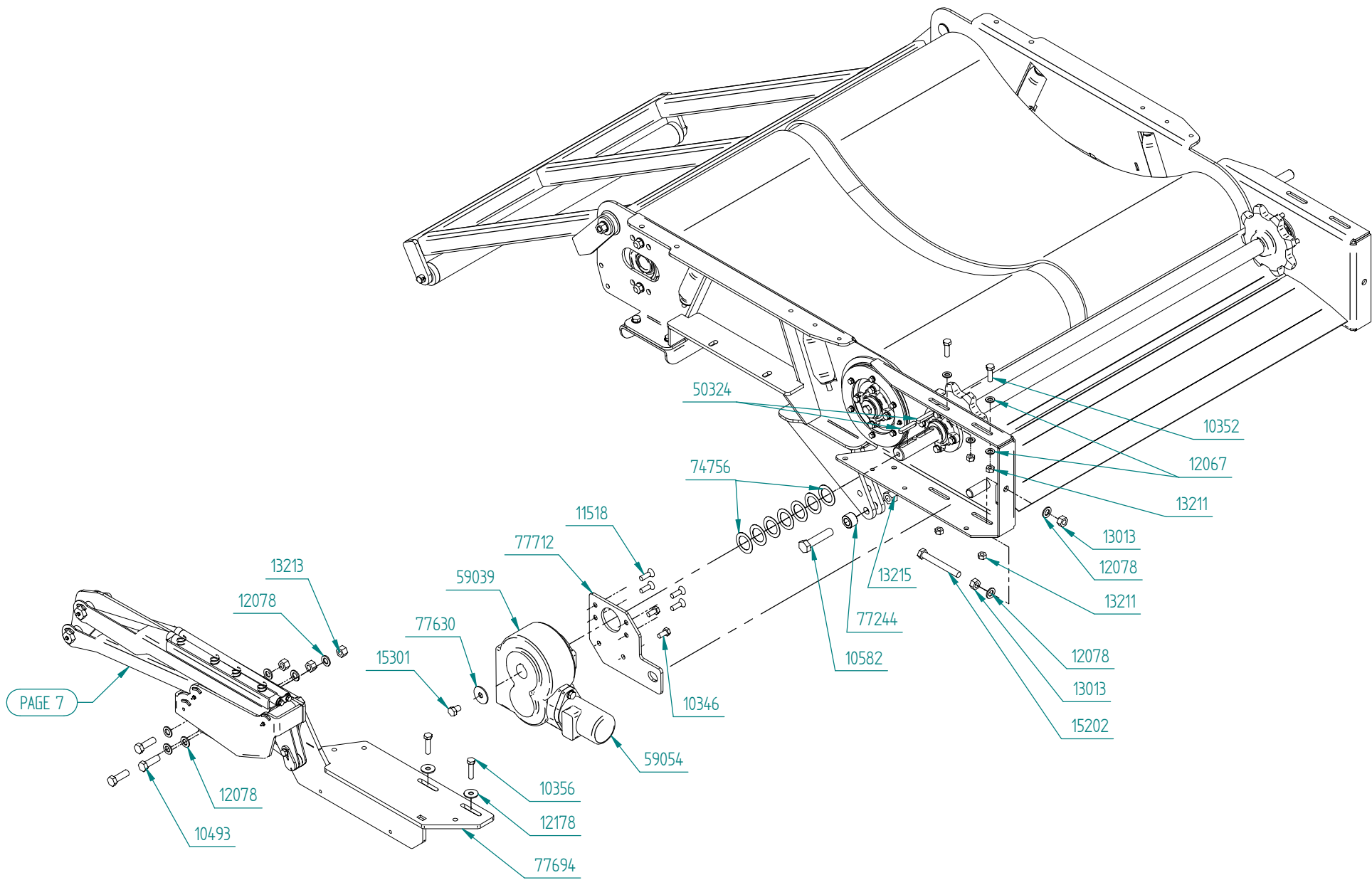

Part number	Qty	Description
10240	2	Bolt M8x16
10246	4	Bolt M8x25
10295	1	Bolt M10x20
10585	1	Bolt M20x120
12047	2	Washer M8
12060	3	Washer M10
12088	5	Washer M20
13210	2	Lock nut M10
13215	5	Lock nut M20
14002	4	Grease nipple M8x1
58577	4	Spring
58870	1	Cylinder 32x16x100
63247	1	Frame, film cutter
63252	1	Tube for cylinder, short
63254	2	Pipe for press arm
63255	1	Shims for pipe, press arm
63256	1	Knife
63257	1	Plate for knife
63258	1	Fastening bolt for cylinder
63259	2	Bolt M20x130 w/grease nipple
63260	2	Bolt M20x100 w/grease nipple
67201	1	Stopper, film cutter
67202	1	Press arm, film cutter
67203	1	Tie rod, film cutter
67205	1	Gasket for cylinder, film stretcher
67206	1	Tube for cylinder, long
67208	1	Stopper bracket

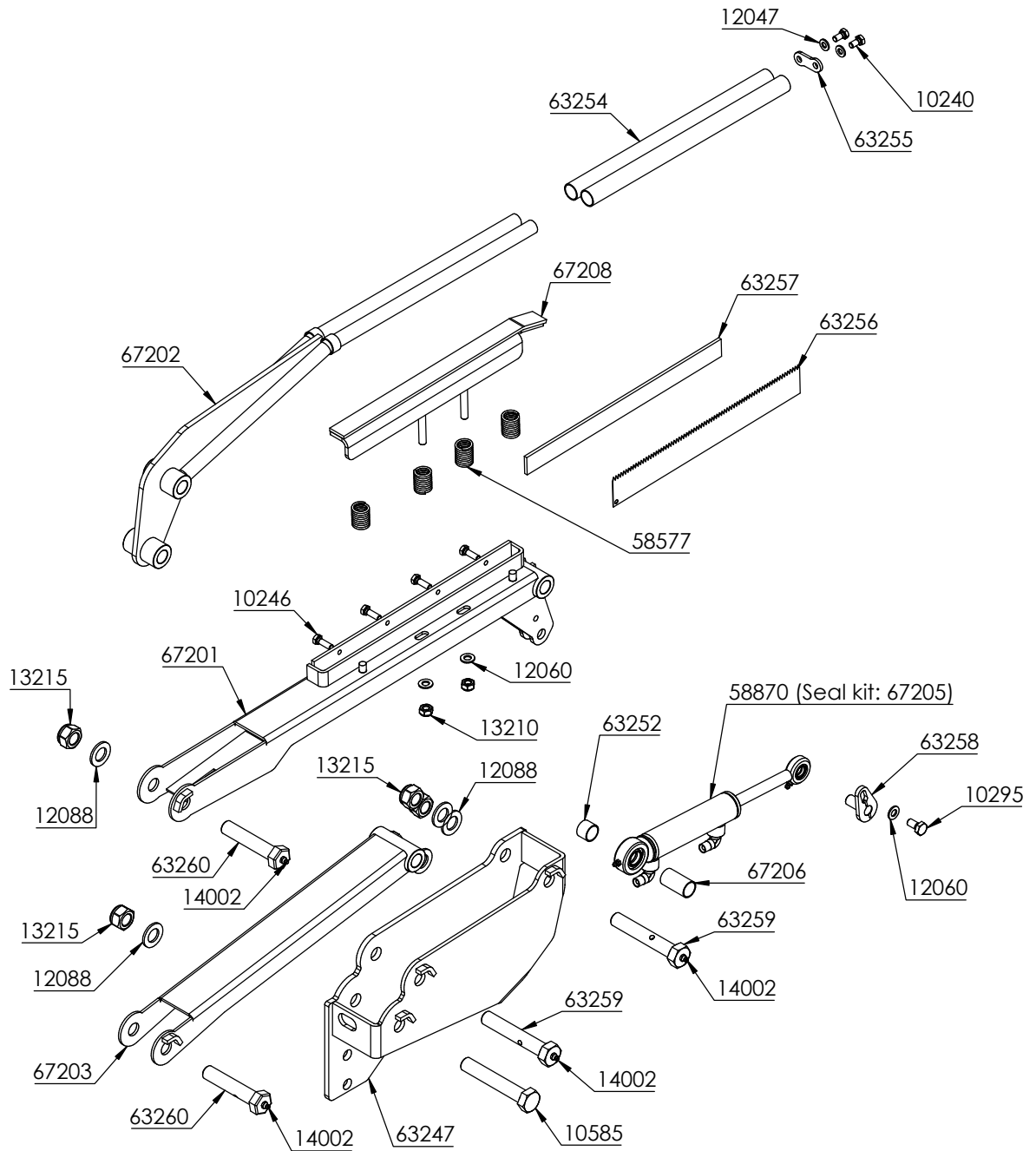
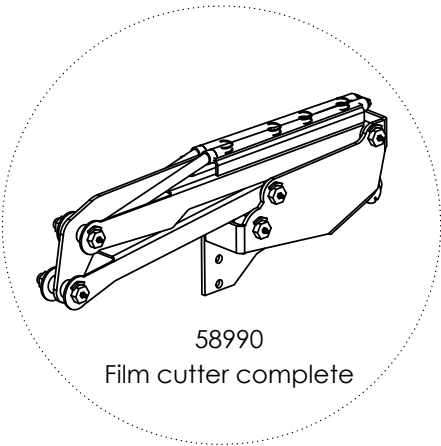

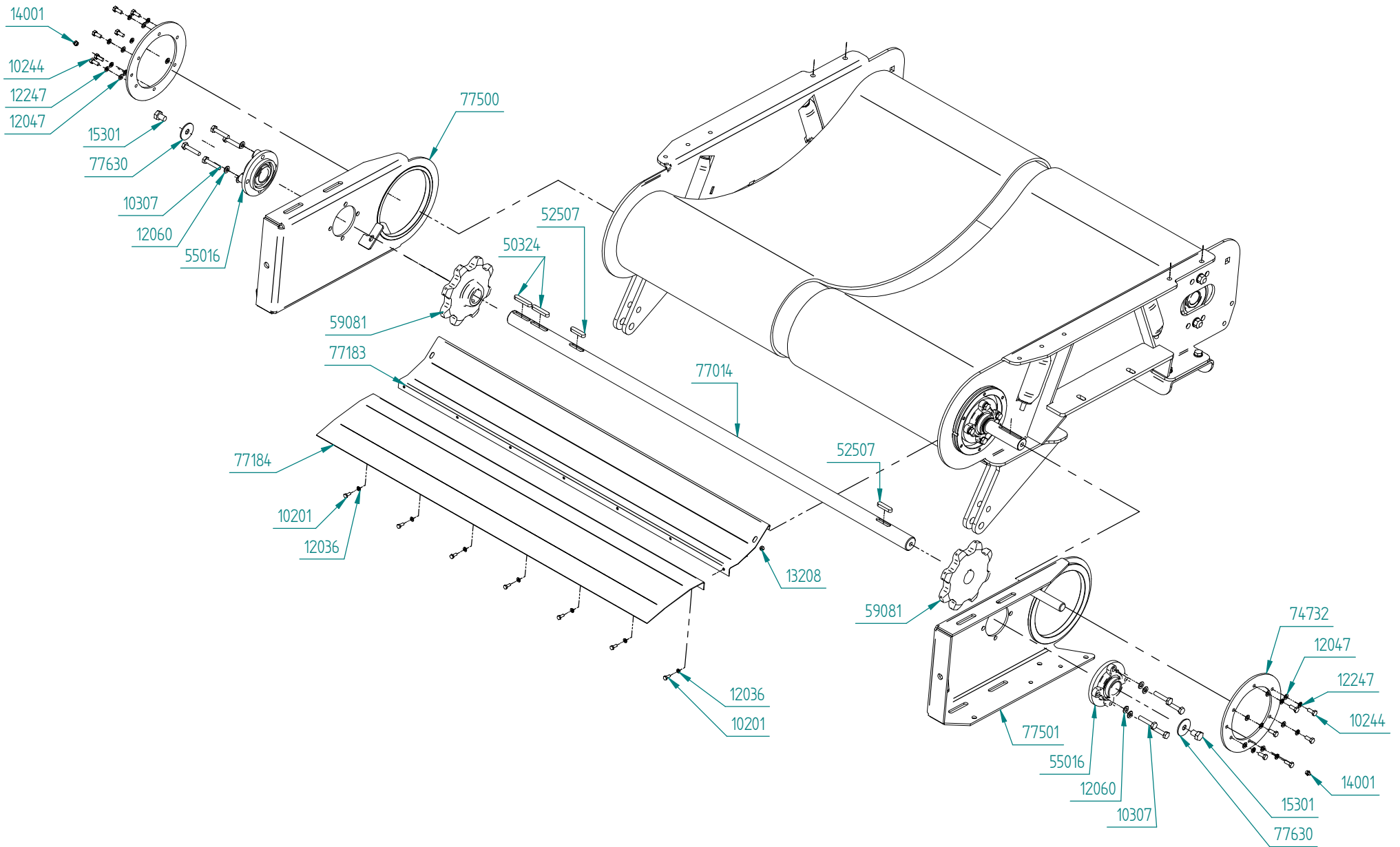

Part Number	Qty.	Title
10201	7	Bolt M6x16, threaded to head
10244	14	Bolt M8x20
10246	12	Bolt M8x25
10250	4	Bolt M8x35
10295	2	Bolt M10x20
10299	4	Bolt M10x30
10303	2	Bolt M10x40
10307	16	Bolt M10x50
10346	2	Bolt M12x25
10348	1	Bolt M12x30
10350	4	Bolt M12x35
10352	7	Bolt M12x40
10356	7	Bolt M12x50
10493	6	Bolt M16x50
10582	2	Bolt M20x90
11138	2	Locking head bolt M16x50
11518	4	Countersunk bolt M12x30
12036	7	Washer M6
12047	28	Washer M8
12060	30	Washer M10
12067	17	Washer M12
12072	8	Washer M14
12078	18	Washer M16
12088	10	Washer M20

Part Number	Qty.	Title
12178	19	Washer \varnothing 37/13x3
12247	12	Spring washer M8
13011	4	Nut M12
13013	4	Nut M16
13208	7	Lock nut M6
13209	10	Lock nut M8
13210	8	Lock nut M10
13211	15	Lock nut M12
13212	4	Lock nut M14
13213	8	Lock nut M16
13215	12	Lock nut M20
14001	3	Grease nipple 1/8" R
14002	10	Grease nipple M8x1
14121	2	Splint \varnothing 8x30
15202	2	Bolt M16x130, threaded to head
15301	4	Bolt M14x20
15313	4	Bolt M12x40
15326	4	Bolt M14x45
15806	3	Washer \varnothing 35/45x2
50324	2	Key 12x8x60
52507	2	Key 12x8x50
52512	1	Key 10x8x80
55016	4	Bearing UCFCX08
58577	8	Spring

Part Number	Qty.	Title
58870	2	Cylinder 50x35x700
59025	2	Bearing UCFL208
59038	1	Gear RT 90
59039	1	Gear RT 160
59053	1	Motor BR200 NC25
59054	1	Motor BG100 NC25
59081	2	Sprocket
59752	1	Angled connection M7 R0HR6x1
59753	1	Straight connection QR1-S-RAI-G018-DA06
59796	1	Belt, wrapper, 2 pcs.
63247	2	Frame, film cutter
63252	2	Tube for cylinder, short
63254	4	Pipe for press arm
63255	2	Shims for pipe, press arm
63256	2	Knife
63257	2	Plate for knife
63258	2	Fastening bolt for cylinder
63259	6	Bolt M20x130 w/grease nipple
63260	4	Bolt M20x100 w/grease nipple
67201	2	Stopper, film cutter
67202	2	Press arm, film cutter
67203	2	Tie rod, film cutter
67205	2	Gasket for cylinder, film stretcher
67206	2	Tube for cylinder, long

Part Number	Qty.	Title
67208	2	Stopper bracket
74732	2	Locking washer for hinge
74756	7	Shim $\varnothing 60/40 \times 1$
77005	1	Roller 1
77006	1	Roller 2
77014	1	Driveshaft, belt under
77027	1	Belt guide, wrapper
77136	1	Bracket, gear
77183	1	Tray 1, towards frame
77184	1	Tray 2, towards frame
77244	2	Spacer, ultrasound sensor
77360	1	Belt guide
77380	1	Sensor bracket
77409	1	Bale tray, roller tube
77413	2	Bale tray, roller bushing
77414	1	Bale tray, roller, shaft
77500	1	Hinge plate left
77501	1	Hinge plate right
77630	4	Washer $\varnothing 50/15 \times 3$
77693	1	Fastening beam, right film cutter
77694	1	Fastening beam, left film cutter
77712	1	Bracket, gear RT 160, reinforced
77728	1	Sensor cover, wrapping table
78039	1	Side plate, left wrapping table

Part Number	Qty.	Title
78040	1	Side plate, right wrapping table
78419	1	Bale tray, frame
78849	1	Crossbar
78850	2	Shim
78851	2	Spacer
78852	2	Lock washer
79705	1	Hose 110mm $\varnothing 6 \times 1,5$



78038

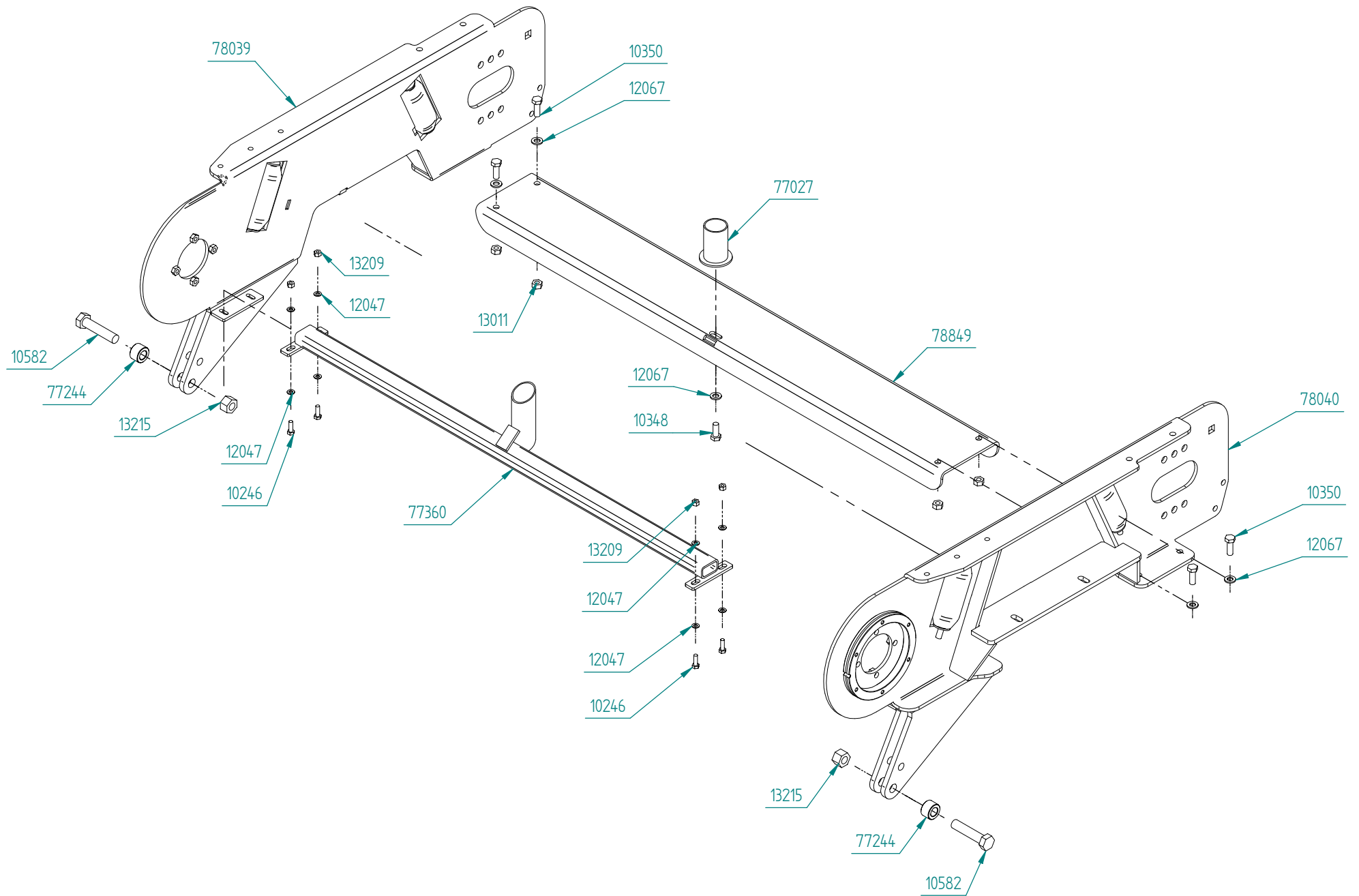

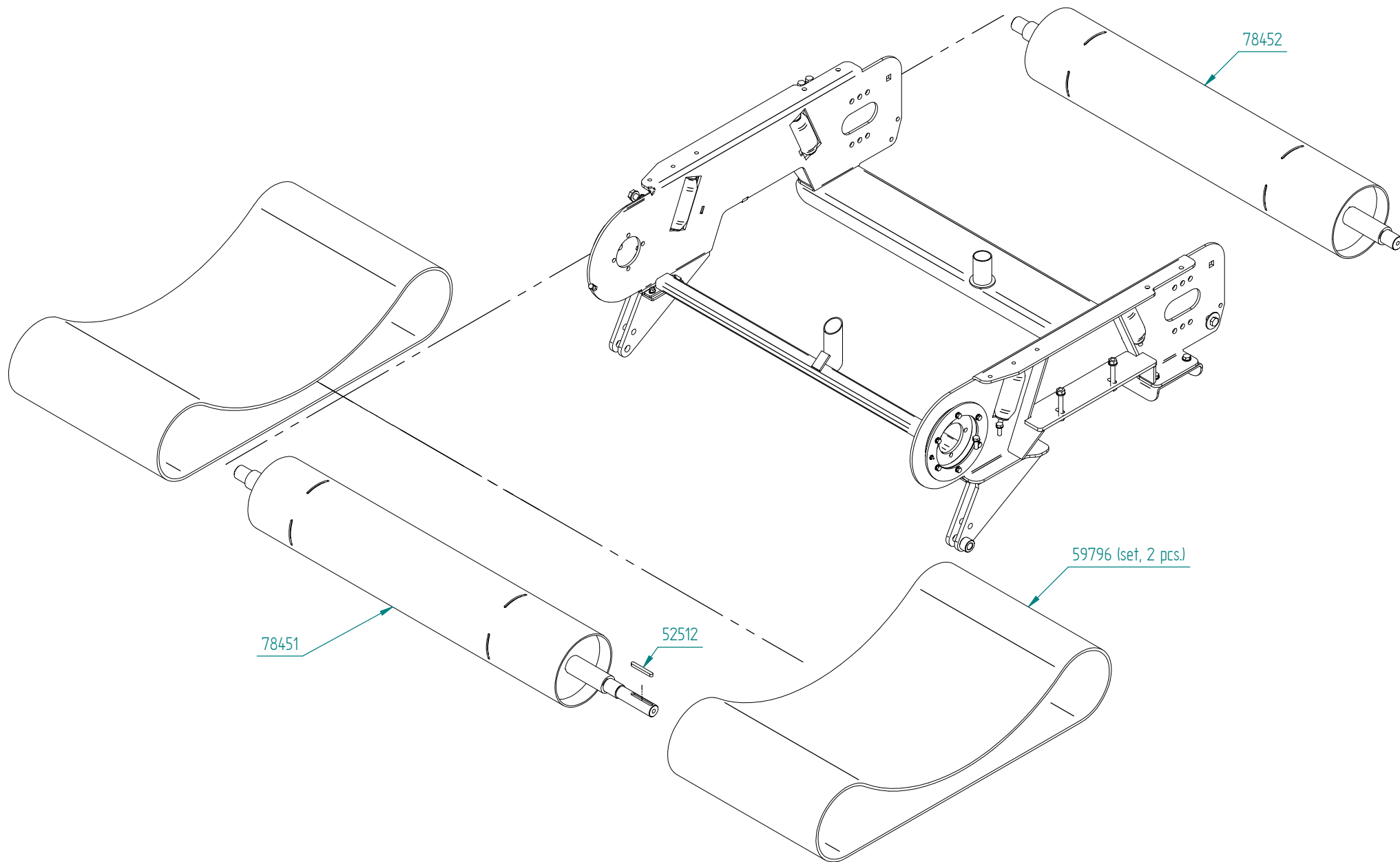

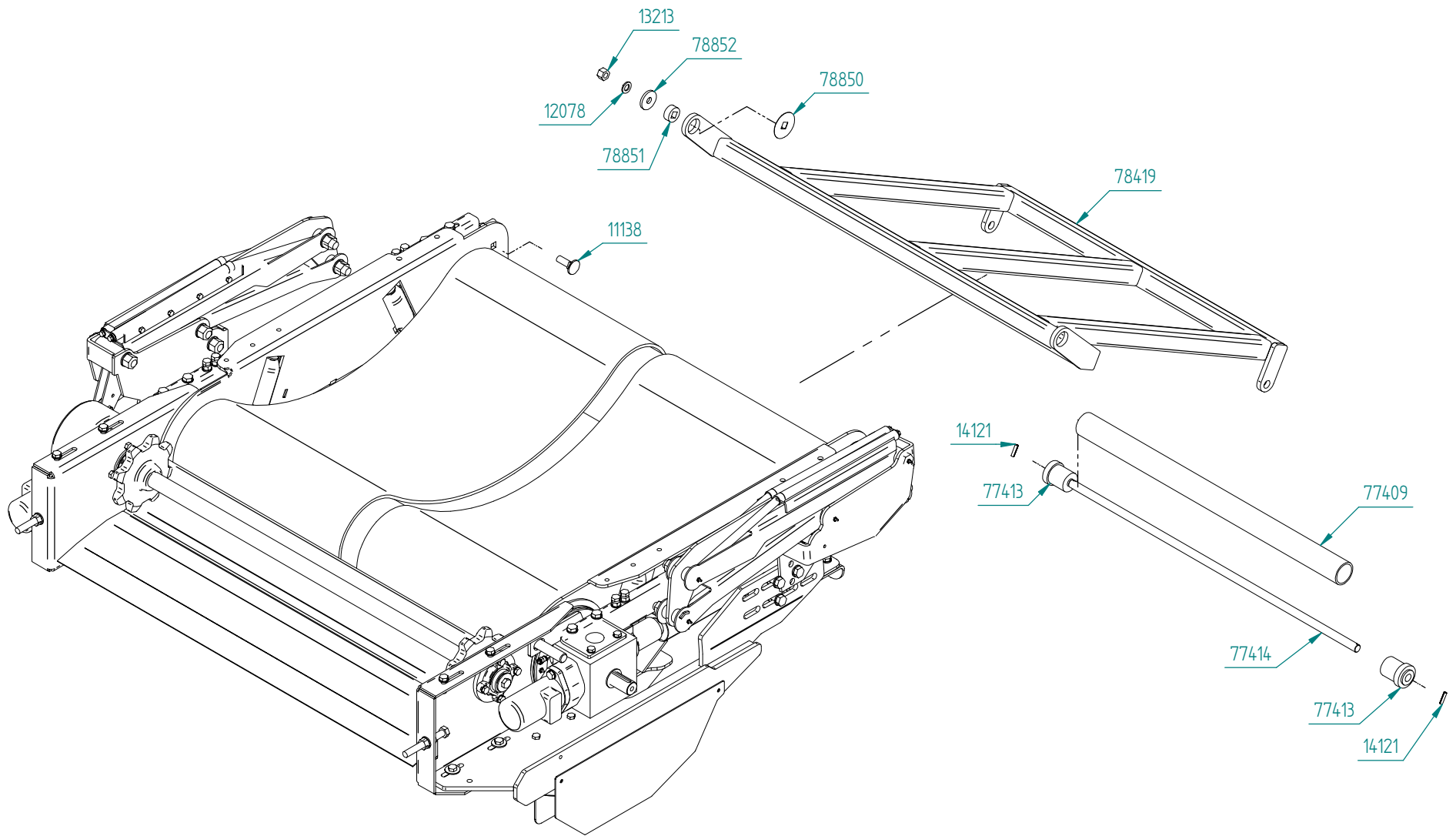

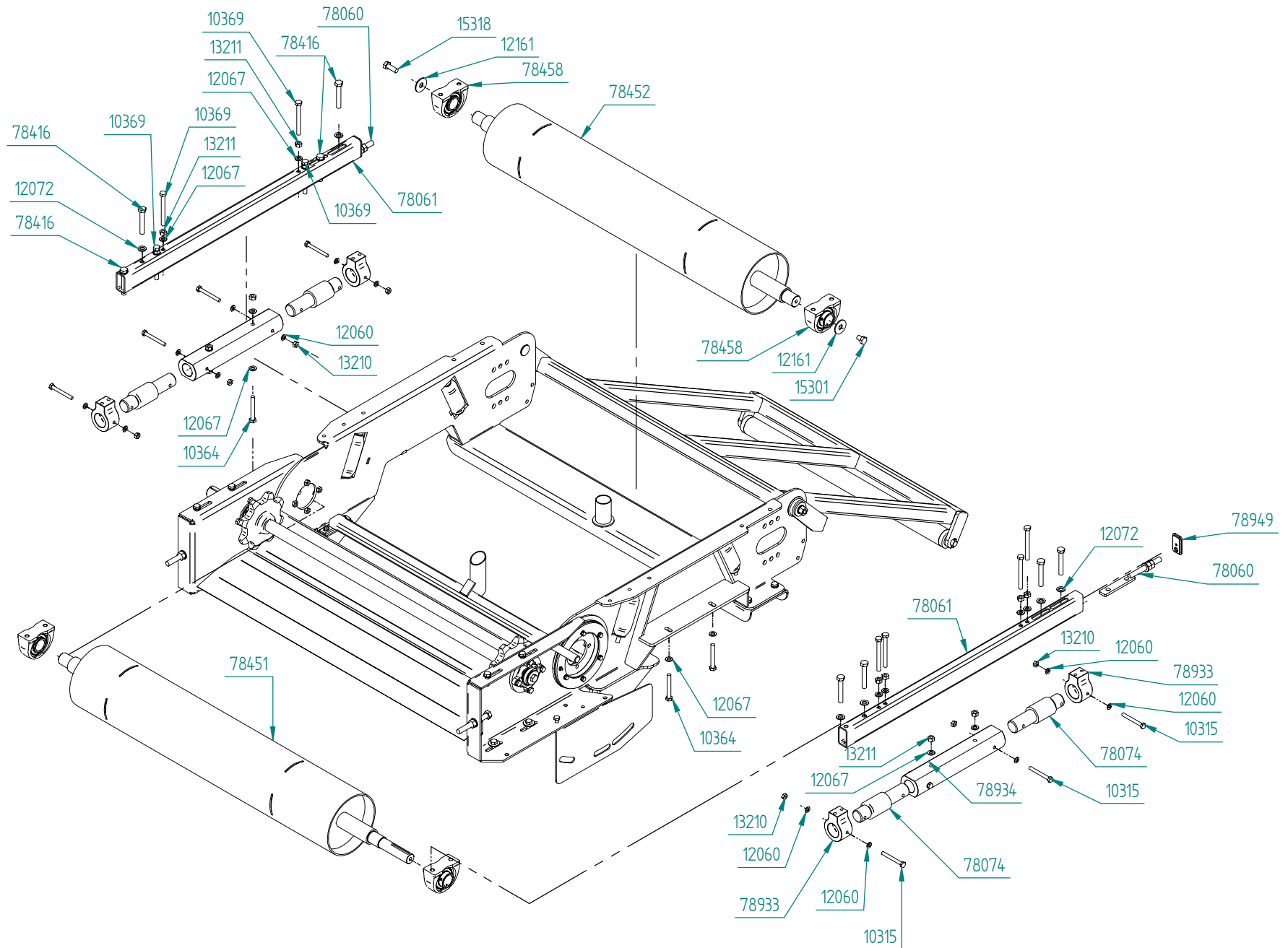

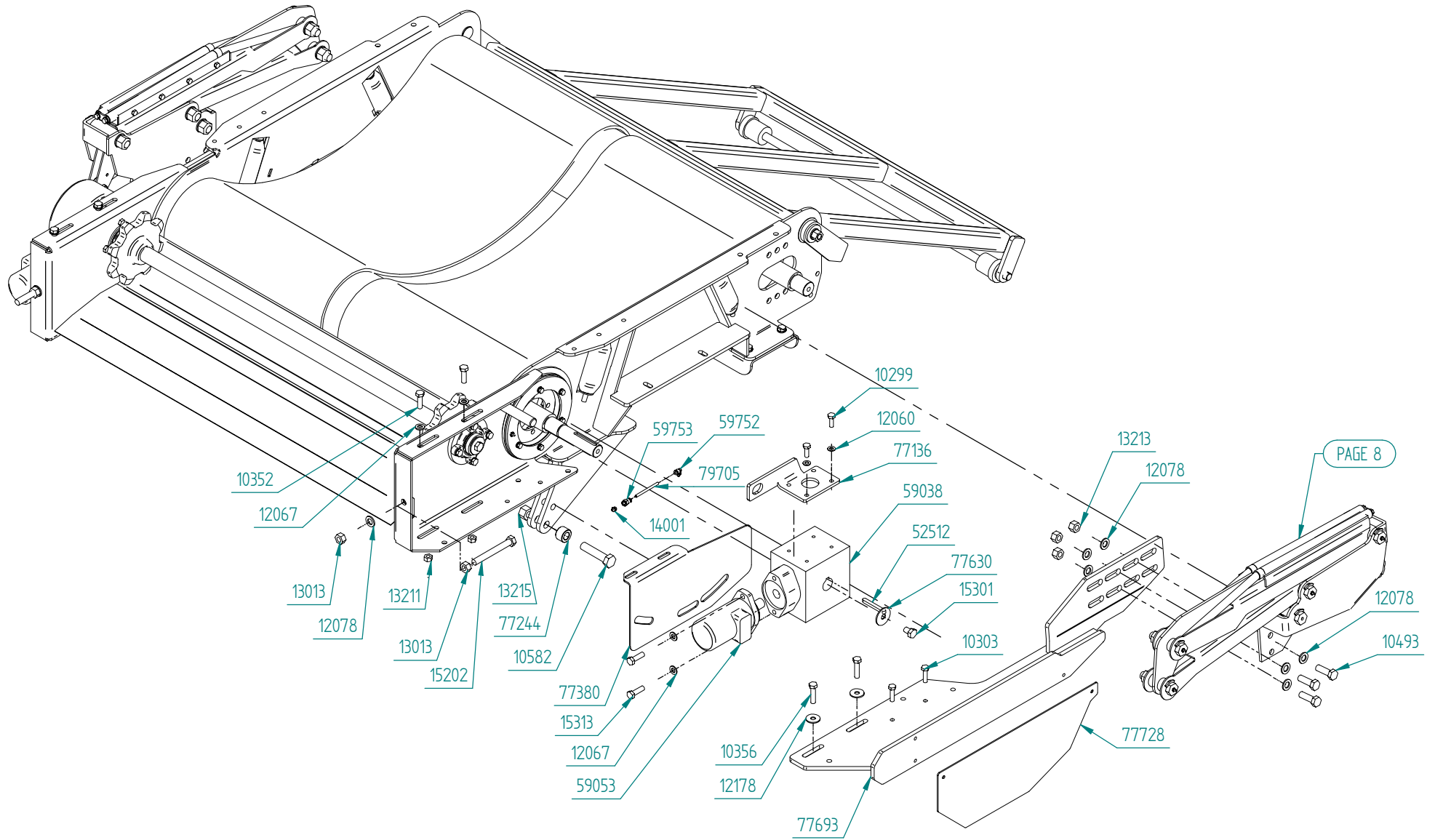

PAGE 8

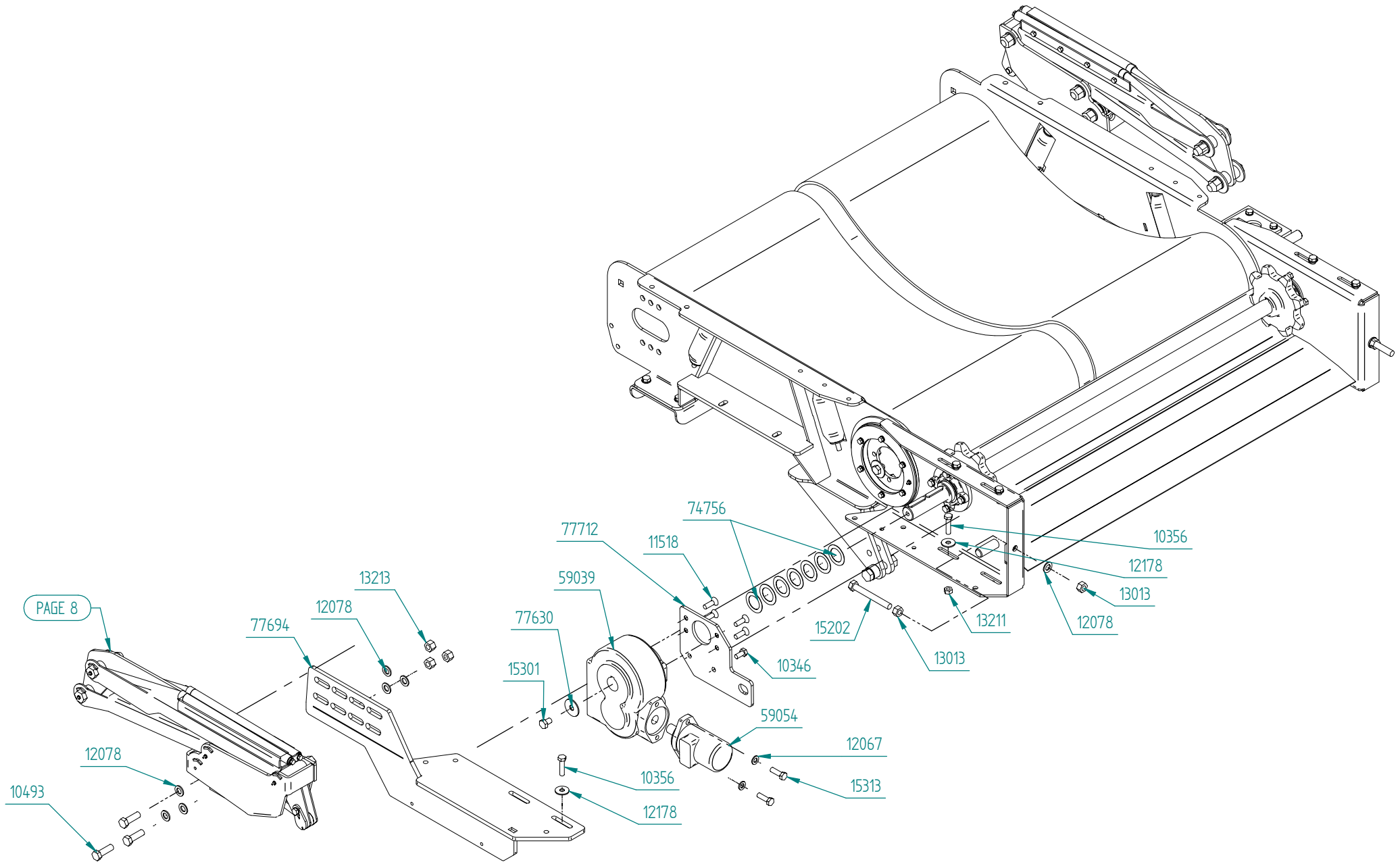

Part number	Qty	Description
10240	2	Bolt M8x16
10246	4	Bolt M8x25
10295	1	Bolt M10x20
10585	1	Bolt M20x120
12047	2	Washer M8
12060	3	Washer M10
12088	5	Washer M20
13210	2	Lock nut M10
13215	5	Lock nut M20
14002	4	Grease nipple M8x1
58577	4	Spring
58870	1	Cylinder 32x16x100
63247	1	Frame, film cutter
63252	1	Tube for cylinder, short
63254	2	Pipe for press arm
63255	1	Shims for pipe, press arm
63256	1	Knife
63257	1	Plate for knife
63258	1	Fastening bolt for cylinder
63259	2	Bolt M20x130 w/grease nipple
63260	2	Bolt M20x100 w/grease nipple
67201	1	Stopper, film cutter
67202	1	Press arm, film cutter
67203	1	Tie rod, film cutter
67205	1	Gasket for cylinder, film stretcher
67206	1	Tube for cylinder, long
67208	1	Stopper bracket

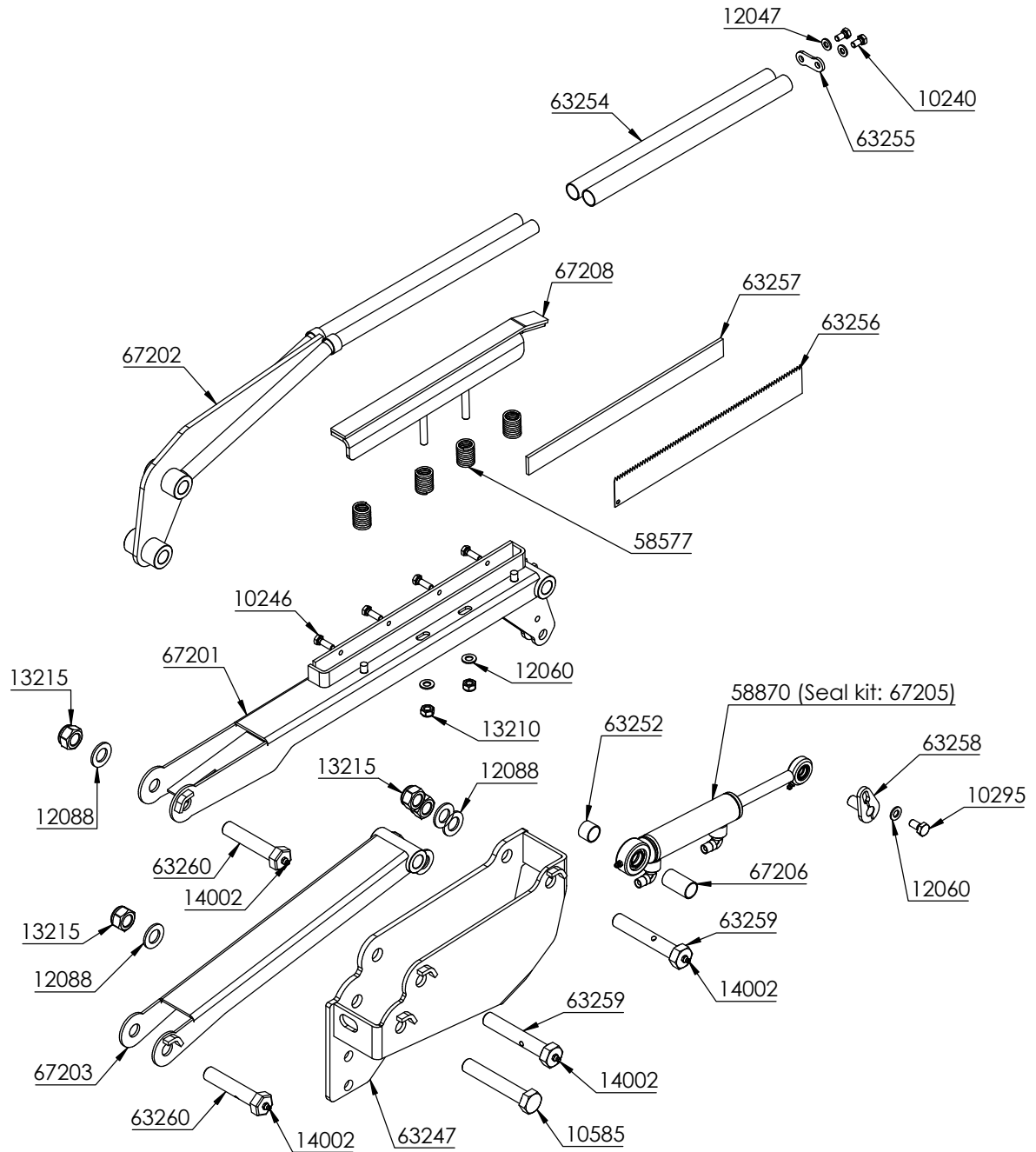
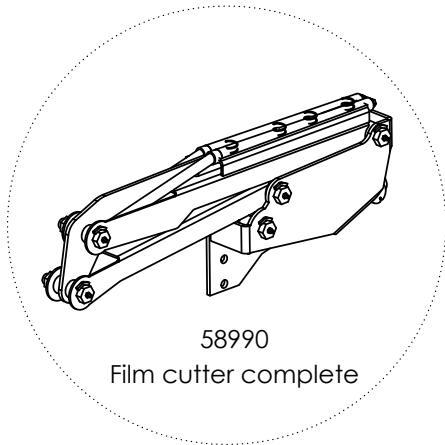

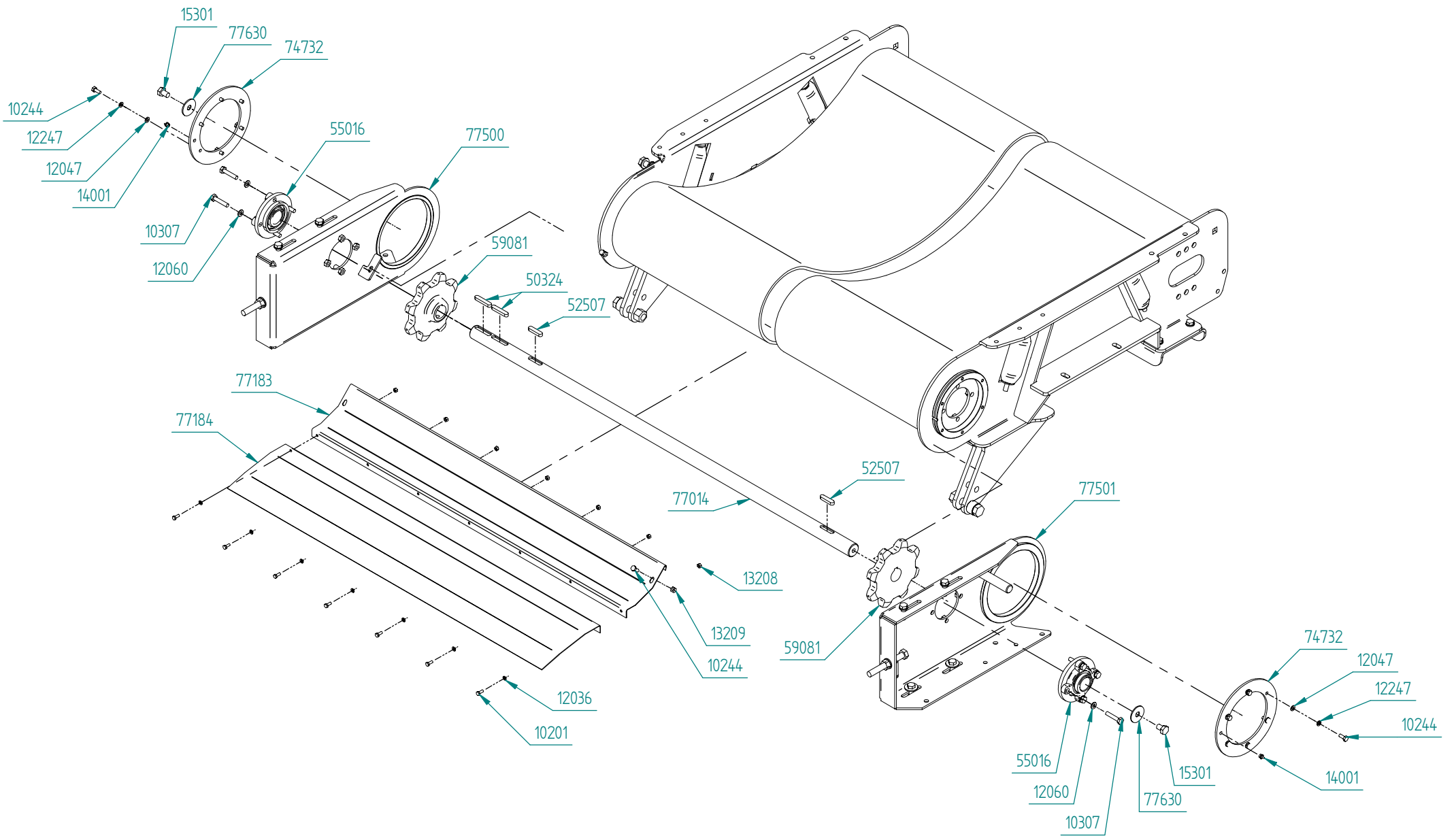

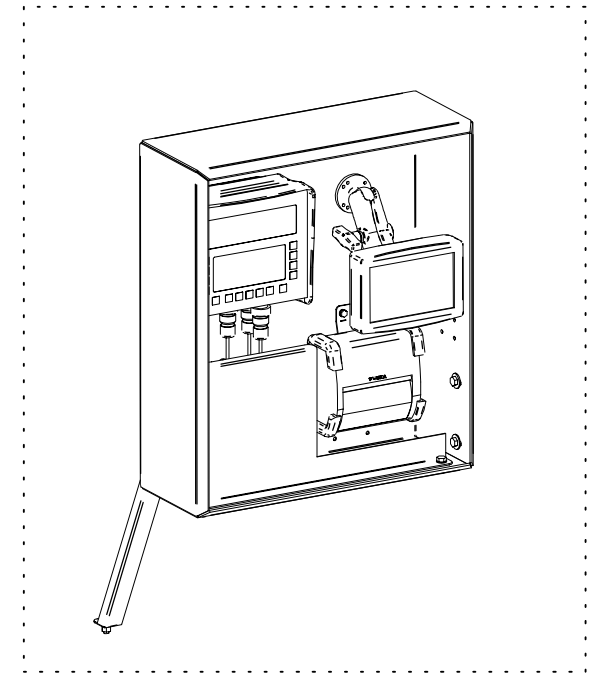
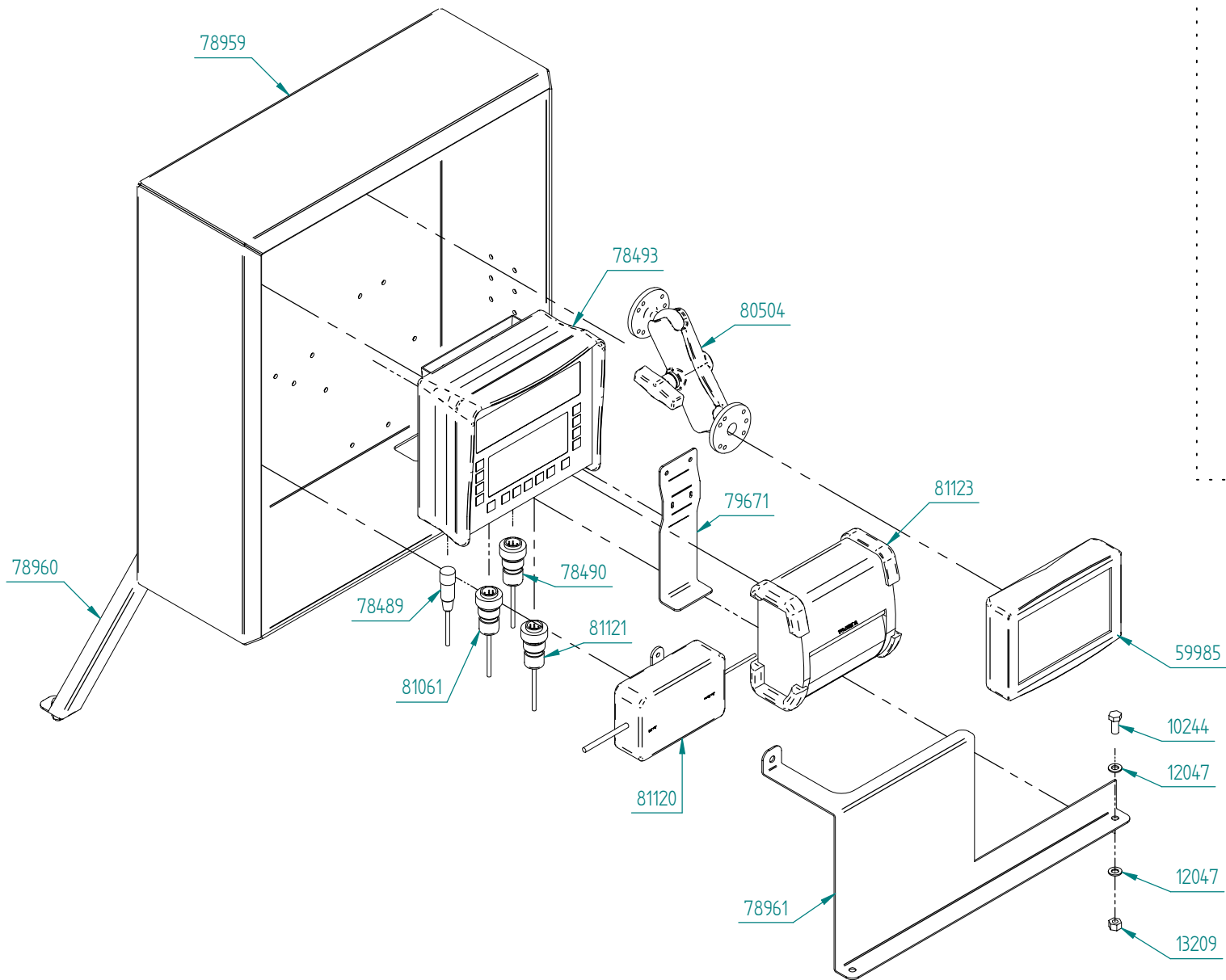

Part Number	Qty.	Title
10201	7	Bolt M6x16, threaded to head
10205	2	Bolt M6x20, threaded to head
10244	19	Bolt M8x20
10246	14	Bolt M8x25
10250	4	Bolt M8x35
10295	2	Bolt M10x20
10299	2	Bolt M10x30
10303	2	Bolt M10x40
10307	8	Bolt M10x50
10315	8	Bolt M10x90
10346	2	Bolt M12x25
10348	1	Bolt M12x30
10350	4	Bolt M12x35
10352	7	Bolt M12x40
10356	7	Bolt M12x50
10364	4	Bolt M12x90
10369	8	Bolt M12x140
10493	6	Bolt M16x50
10582	2	Bolt M20x90
11138	2	Locking head bolt M16x50
11518	4	Countersunk bolt M12x30
12017	2	Washer M3
12036	11	Washer M6
12047	40	Washer M8

Part Number	Qty.	Title
12060	28	Washer M10
12067	33	Washer M12
12072	8	Washer M14
12078	20	Washer M16
12088	10	Washer M20
12147	2	Washer ϕ 24/8,4x2
12161	2	Washer ϕ 50/17x3
12178	19	Washer ϕ 37/13x3
12228	2	Spring washer M3
12247	12	Spring washer M8
13011	4	Nut M12
13013	6	Nut M16
13208	9	Lock nut M6
13209	17	Lock nut M8
13210	8	Lock nut M10
13211	27	Lock nut M12
13213	10	Lock nut M16
13215	12	Lock nut M20
13621	2	Pan bolt M3x8
14001	3	Grease nipple 1/8" R
14002	10	Grease nipple M8x1
14121	2	Splint ϕ 8x30
15202	2	Bolt M16x130, threaded to head
15301	5	Bolt M14x20

Part Number	Qty.	Title
15313	4	Bolt M12x40
15318	1	Bolt M14x40
50324	2	Key 12x8x60
52507	2	Key 12x8x50
52512	1	Key 10x8x80
55016	2	Bearing UCFEX08
58577	8	Spring
58870	2	Cylinder 50x35x700
59038	1	Gear RT 90
59039	1	Gear RT 160
59053	1	Motor BR200 NC25
59054	1	Motor BG100 NC25
59081	2	Sprocket
59752	1	Angled connection M7 ROHR6x1
59753	1	Straight connection QR1-S-RAI-G018-DA06
59796	1	Belt, wrapper, 2 pcs.
59985	1	Display unit
63247	2	Frame, film cutter
63252	2	Tube for cylinder, short
63254	4	Pipe for press arm
63255	2	Shims for pipe, press arm
63256	2	Knife
63257	2	Plate for knife
63258	2	Fastening bolt for cylinder

Part Number	Qty.	Title
63259	6	Bolt M20x130 w/grease nipple
63260	4	Bolt M20x100 w/grease nipple
67201	2	Stopper, film cutter
67202	2	Press arm, film cutter
67203	2	Tie rod, film cutter
67205	2	Gasket for cylinder, film stretcher
67206	2	Tube for cylinder, long
67208	2	Stopper bracket
74732	2	Locking washer for hinge
74756	7	Shim $\phi 60/40 \times 1$
77014	1	Driveshaft, belt under
77027	1	Belt guide, wrapper
77136	1	Bracket, gear
77183	1	Tray 1, towards frame
77184	1	Tray 2, towards frame
77244	2	Spacer, ultrasound sensor
77360	1	Belt guide
77380	1	Sensor bracket
77409	1	Bale tray, roller tube
77413	2	Bale tray, roller bushing
77414	1	Bale tray, roller, shaft
77500	1	Hinge plate left
77501	1	Hinge plate right
77630	4	Washer $\phi 50/15 \times 3$

Part Number	Qty.	Title
77693	1	Fastening beam, right film cutter
77694	1	Fastening beam, left film cutter
77712	1	Bracket, gear RT 160, reinforced
77728	1	Sensor cover, wrapping table
78039	1	Side plate, left wrapping table
78040	1	Side plate, right wrapping table
78060	2	Tightening bolt, weighing system
78061	2	HUP, load cell, weldment parts
78074	4	Load cell
78416	8	Bolt M14x90
78419	1	Bale tray, frame
78451	1	Roller 1, weighing system
78452	1	Roller 2, weighing system
78458	4	Bearing UCPA 208
78489	1	Kabel, koblingsboks - terminal
78490	1	Kabel, strømtilførsel veieterminal
78491	1	Junction box, ECP, 4 load cells
78493	1	DG600 Compactor scale (veieterminal)
78849	1	Crossbar
78850	2	Shim
78851	2	Spacer
78852	2	Lock washer
78933	4	Ring 1, load cell
78934	2	Ring 2, load cell

Part Number	Qty.	Title
78949	2	Fastening plate, belt tightener
78959	1	Cover display, w/weighing system
78960	1	Supporting bar, case for display
78961	1	Cable cover, case, display, w/weighing system
79671	1	Bracket for printer
79705	1	Hose 110mm $\phi 6 \times 1,5$
80504	1	RAM-fastener, complete
81061	1	Cable, print activation
81120	1	DC Adapter
81121	1	Printer cable
81123	1	Printer Toshiba
81138	1	Optocoupler 0,1A

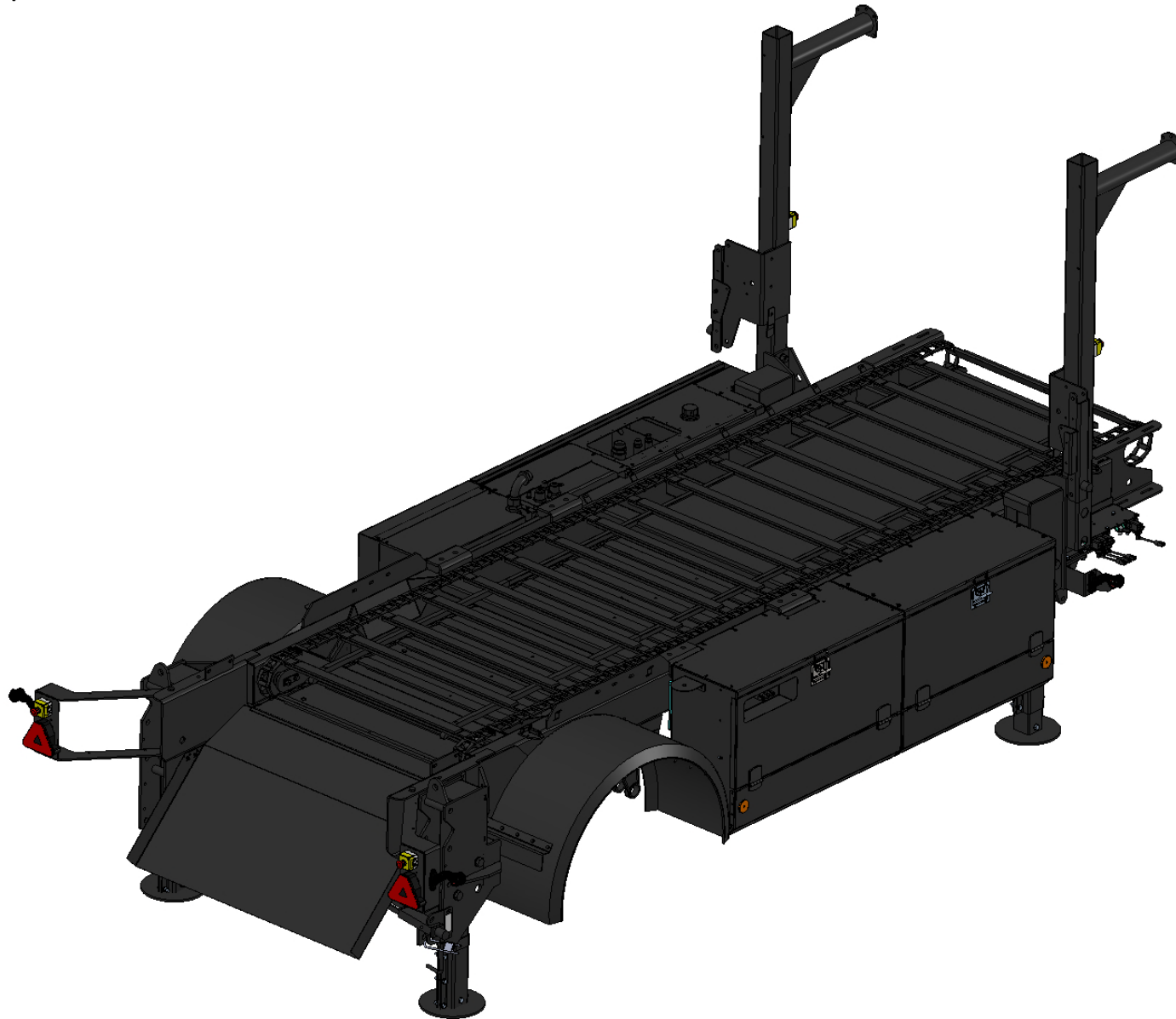

79737

Part number	Qty	Description
57547	1	Spring
77510	2	Light bracket
77628	2	Lifting lug
78827	1	Bracket, frame, lower left
79346	1	Cover for inspection slot
59211	2	Bulkhead fitting 30 strong
59203	1	Bulkhead fitting 1/4"
59245	2	Bulkhead fitting 3/8"
80711	1	Bulkhead fitting 3/4"
79795	1	Cover
80004	2	Emergency switch
81037	2	Agripoint Full LED 5 pin connector
81038	1	Marker light, left LED
81039	1	Marker light, right LED
82511	1	Hydraulic directional valve (1)
82685	1	Pipe plug 1/4-18 NPTF
82509	1	Hydraulic directional control valve (3)
59177	6	Adaptor 3/8"-1/4"
59178	1	Adaptor 3/8"-3/8"
35011	2	Fitting 1/2" utv. x 3/8" utv.

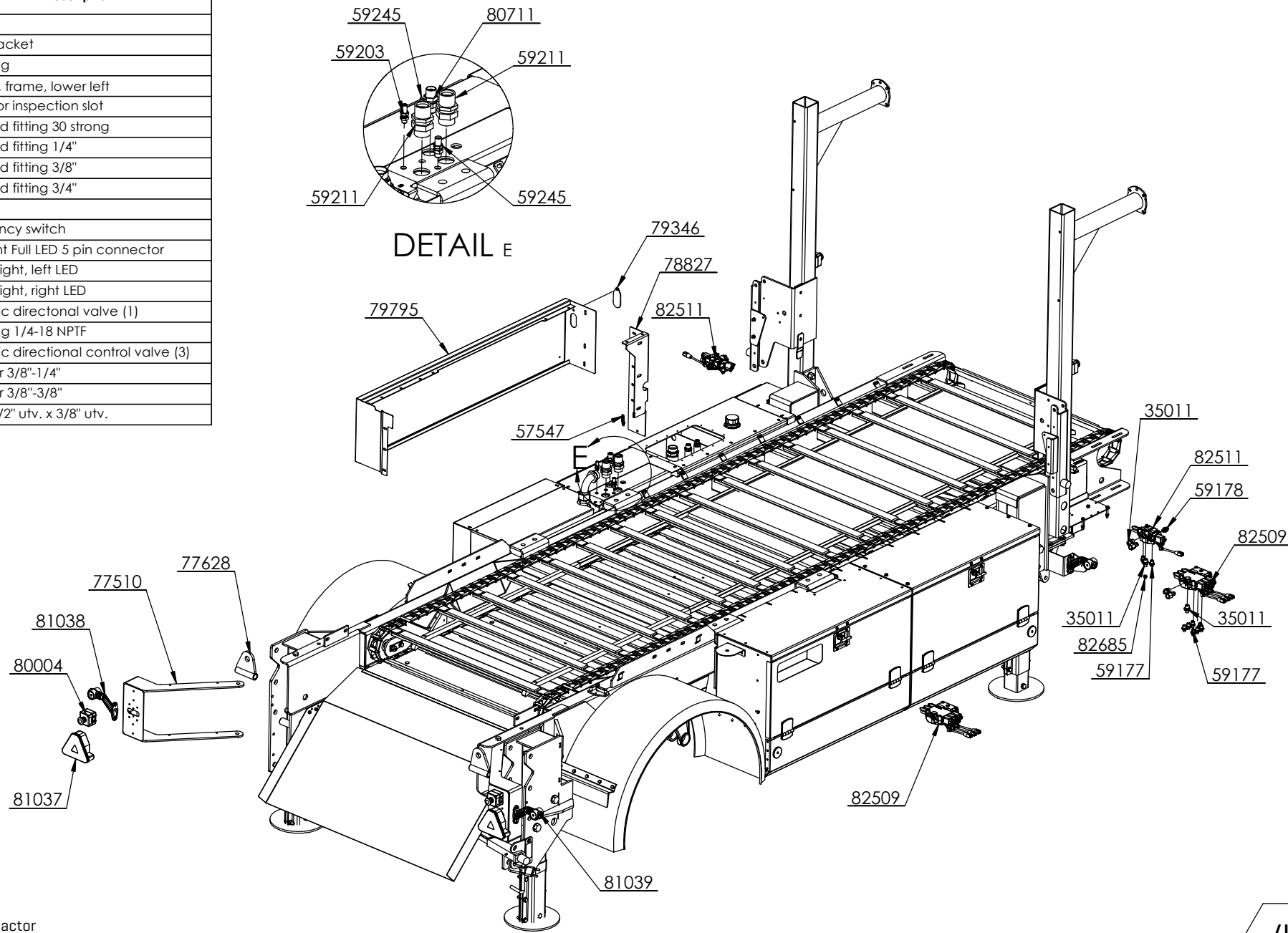

Part number	Qty	Description
77748	1	Cover above generator
78927	1	Duct, hydraulic hoses, below frame
78976	1	Cover above generator strap
79789	1	Bracket for pump
80025	1	Pump set
59952	1	Alternator 24V 55A
59953	1	V-belt pulley $\varnothing 73$
59955	1	V-belt pulley SPA 236
59954	1	Belt XPA 1030
80027	1	Alternator fan
79878	1	Spacer, alternator
78700	1	Adjustment bracket for generator
82352	1	Taperlock hub 2012 1-3/8" Z6
80482	1	Guard above PTO pin, complete
59034	1	Hinge
82129	1	Safety lock, support PTO drive shaft

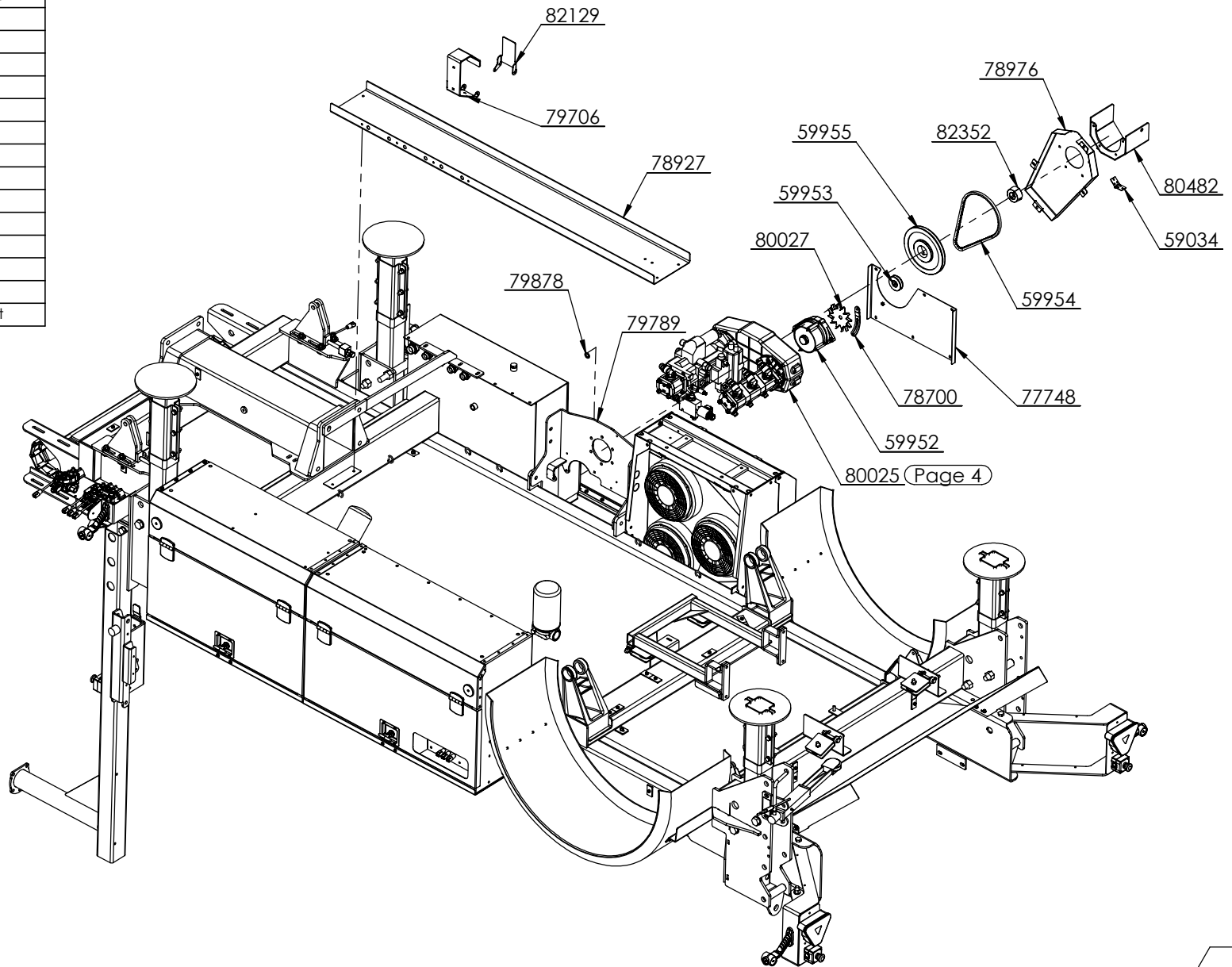

Part number	Qty	Description
59080	1	Triple pump
59419	3	Port flange $\varnothing 40 \times 3/4"$
59266	3	Port flange 90Gr $\varnothing 30 \times 1/2"$
59967	1	Spline shell 50-45 z24 16-32 z21
80707	1	Hydrostatic pump w/flange
80012	1	Centering disk Borelli 920266
59966	1	Spline shell 50-45 z24 18 gr.
80718	1	Pressure sensor 0-600 bar
59963	1	Borelli 91001 gear
59964	1	Flange gr. 2
59965	1	Flange SAE C
80019	12	Bolt M12 special for Borelli 91001
53306	4	Gasket 1/2"
35010	3	Fitting 1/2"-1/2"
59185	1	Fitting 1/2" - 1/2"
58650	8	Gasket
59192	5	Fitting 3/4"-3/4"
35633	3	Bonded seal 1/4"
58635	1	Fitting 1/4"-1/4"
59191	1	Coupling 1/4"
80841	1	Fitting 1/4"-1/4", 2mm throttle
12072	4	Washer 15 DIN 125A -140HV FZV
15337	4	Bolt M14x35
15156	8	Bolt M8 x 30 ISO 4762 12.9 flZn
59381	1	Filter element, pressure
80003	1	Pump gr.2 10,6ccm
80356	1	Directional Valve, 3-way, complete
80359	1	Housing CP12-3-6B 3/4"
80360	1	Valve, 3-way
80346	1	Coil for PSV12
59179	2	Fitting 1/2" utv.-3/4" utv.
58639	1	Fitting 3/8" utv.-3/4" utv.
59175	1	Gasket 1"
59326	1	Fitting 1" 1/4" - 3/4"
12453	8	Nord-Lock washer M8

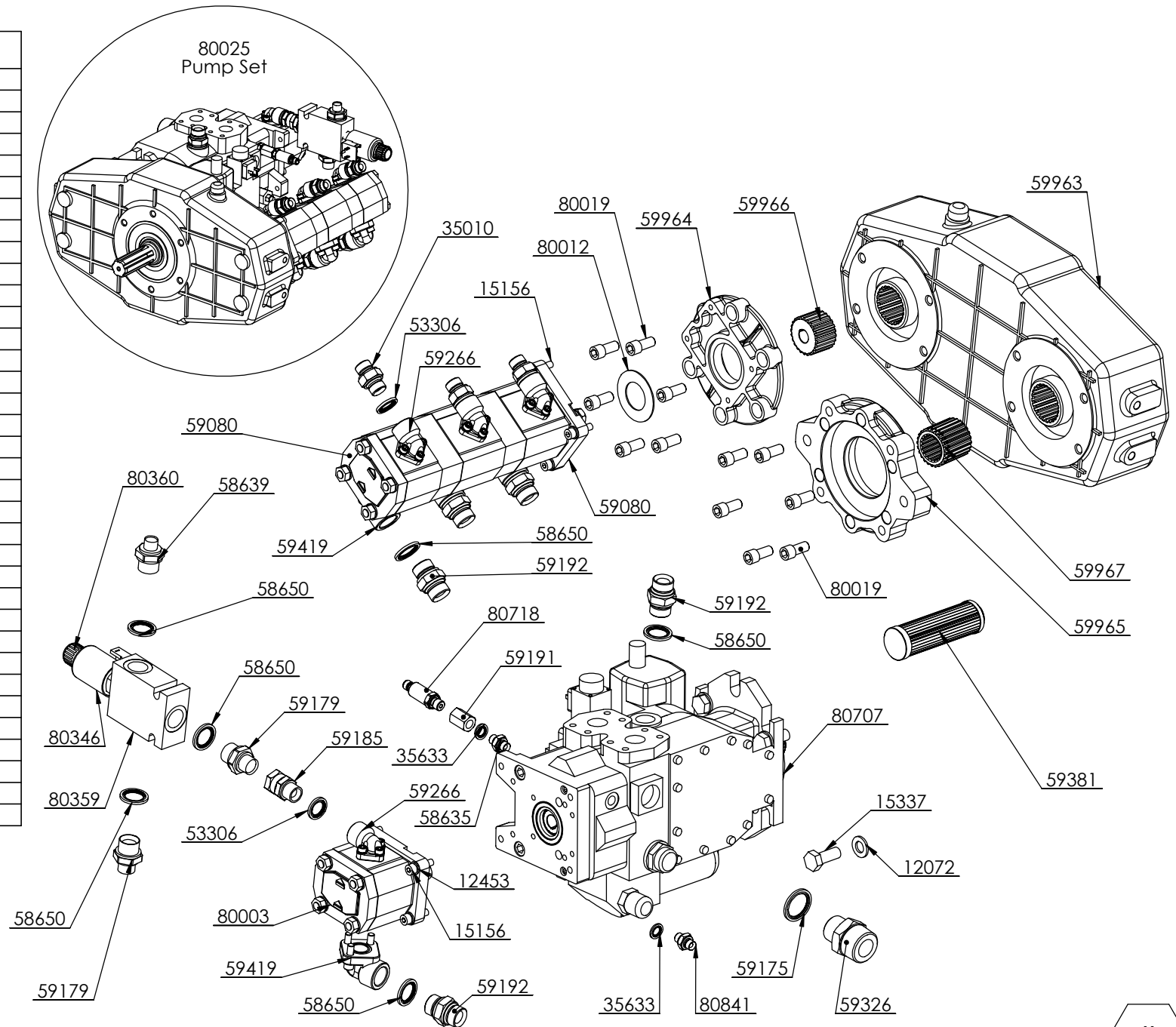

Part number	Qty	Description
78683	1	Rod, left side
78684	1	Rod, right side
78904	1	Gas spring bracket RB LF LB
78903	1	Gas spring bracket RF
58104	2	Rubber buffer, complete
80004	2	Emergency switch
59937	1	Filter head
59939	1	Filter element, low pressure
59733	1	Filter head
59734	1	Suction filter
11107	4	Lock head bolt M8x30
12047	44	Washer 8,4 DIN 125A -140HV FZV
13209	38	Lock nut M8
12088	12	Washer 21 DIN 125A -140HV FZV
10577	6	Bolt M20 x 60 DIN 933 8.8 FZV
13215	6	Lock nut M20
14901	2	Reflector ø60 white
81039	1	Marker light, right LED
82307	2	Holder for spilltray
82177	1	Bracket for plastic storage
82178	1	Bracket for plastic storage, left front
78718	1	Electric cabinet, rear
78719	1	Hydraulic cabinet
59958	1	Hydraulic manifold HIC 1
59959	1	Hydraulic manifold HIC 2
59962	1	Collector manifold
78831	1	Battery box, master
81069	1	Housing

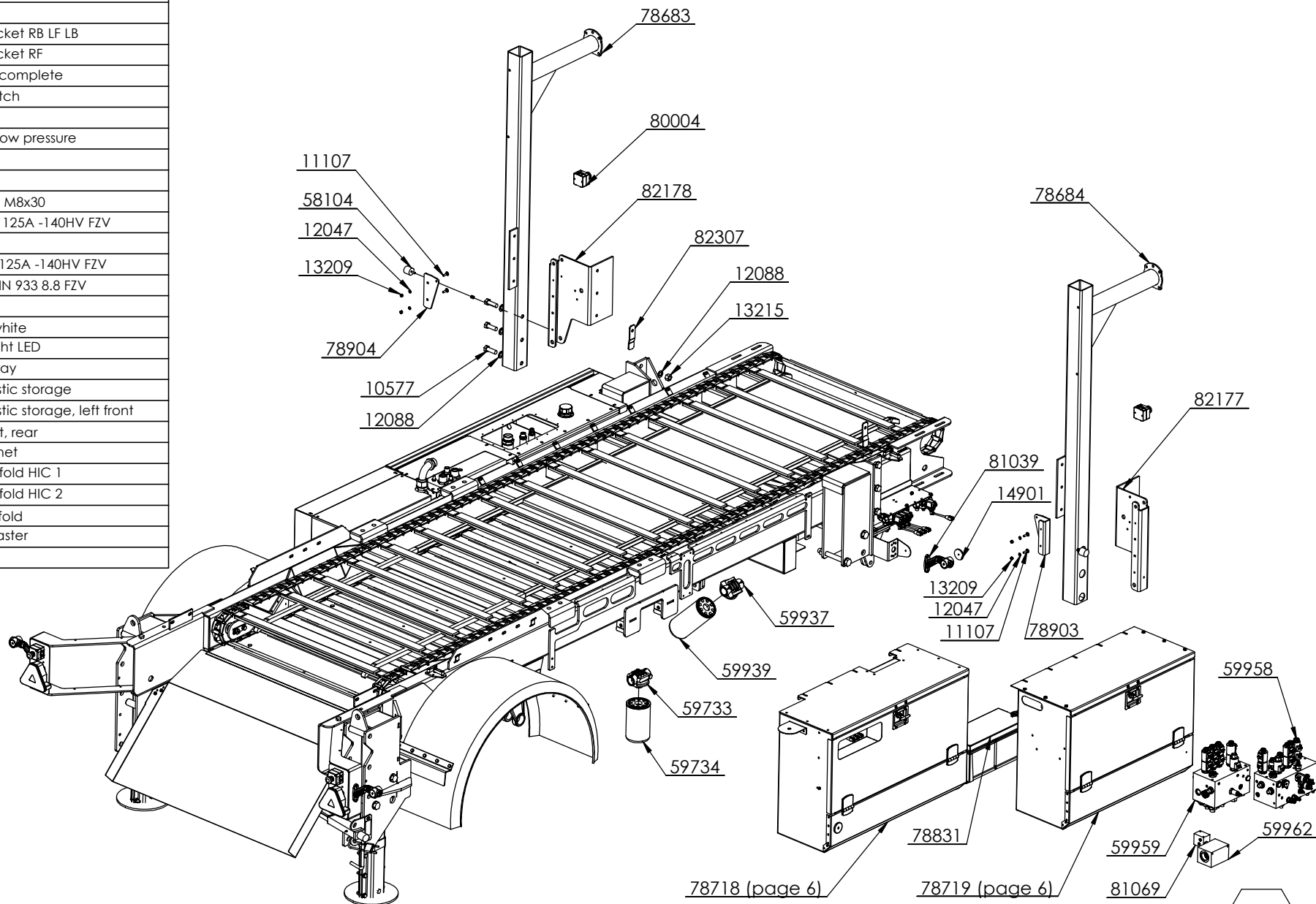

Part number	Qty	Description
59410	2	Reflex ø60, orange
59949	2	Battery 12V 44Ah
82439	1	Rear wall el-cabinet
78707	1	Electric cabinet sprayhood valves
59411	1	Door lock
12036	9	Washer 6,4 DIN 125A -140HV FZV
13208	4	Lock nut M6
78802	1	Bracket
78884	1	Cover below electric cabinet
15904	4	Screw M6 x 16 ISO 7380 with flange
82441	1	Bottom plate el-cabinet
82437	1	Sidewall, left, El-cabinet
82442	1	Top plate, el-cabinet
82443	1	Hatch, el-cabinet
82637	2	Hinge, heavy duty, alu
78792	2	Spacer for electric cabinet
16503	2	Bolt M8x20, black
82464	1	Mount for 4G antenna
82453	1	Rear wall hydraulic cabinet
82448	1	Base plate hydraulic cabinet
82446	1	Sidewall, right, hydraulic cabinet
82447	1	Sidewall, left, hydraulic cabinet
82449	1	Front hatch hydraulic cabinet
78712	1	Lock counterpart, hydraulic cabinet
82451	1	Top cover hydraulic cabinet
82638	12	Poprivet, stainless, 4,8x12
12047	22	Washer M8 DIN 125A
10240	10	Bolt M8 x 16 DIN 933
11460	2	Screw M8 x 16 ISO 7380
78832	1	Bracket for battery
78833	1	Clamp for battery
78834	1	Cover for battery
14302	2	Ear pin M6
79911	1	Locking plate
80107	1	Electric cabinet, complete
81073	1	Valve block assembly, with 24V coil
81074	1	Main power switch
59958	1	Hydraulic manifold HIC 1
80464	1	Elbow 1" with set screw
59959	1	Hydraulic manifold HIC 2
80022	1	Fitting 3/4"-3/4"
82474	1	Collector manifold, complete
82586	1	Hydraulic valve, 3-levers, complete
16312	1	Warning label PTO

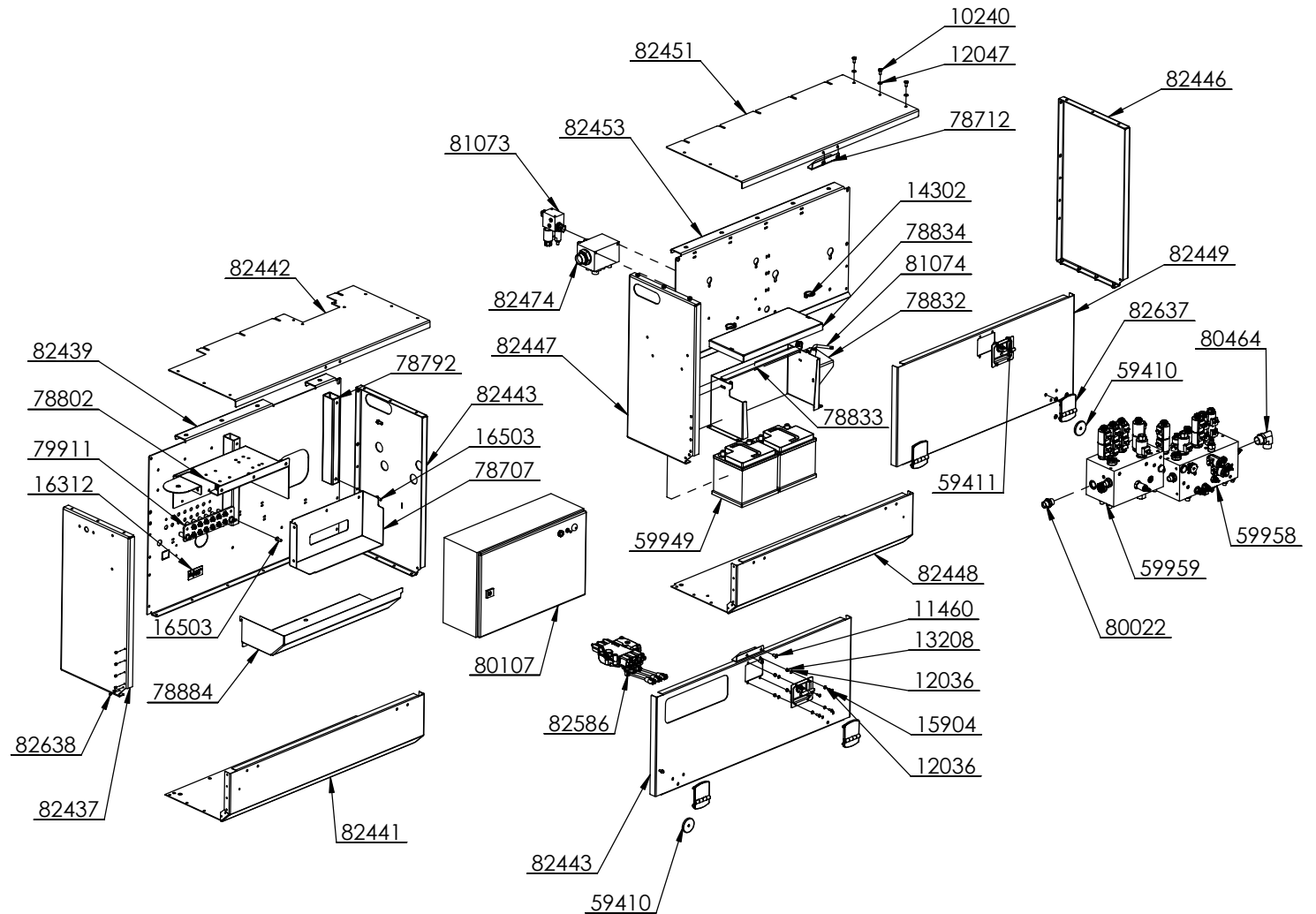

Part number	Qty	Description
10244	20	Bolt M8 x 20 DIN 933 8.8 FZV
10246	8	Bolt M8 x 25 DIN 933 8.8 FZV
10259	6	Bolt M8x60
10354	8	Bolt M12 x 45 DIN 931 8.8 FZV
10356	28	Bolt M12 x 50 DIN 931 8.8 FZV
10364	4	Bolt M12 x 90 DIN 931 8.8 FZV
10493	4	Bolt M16 x 50 DIN 933 8.8 FZV
10667	8	Bolt M24x200
12047	44	Washer 8,4 DIN 125A -140HV FZV
12067	68	Washer 13 DIN 125A -140HV FZV
12072	8	Washer 15 DIN 125A -140HV FZV
12078	8	Washer 17 DIN 125A -140HV FZV
12093	8	Washer 25 DIN 125A -140HV FZV
12173	12	Washer $\varnothing 24/8,4 \times 2$
12178	16	Washer 13 x 37 x 3 DIN 9021 FZV
12247	4	Spring washer 8,1 DIN 127 B FZV
13209	38	Lock nut M8
13211	40	Lock nut M12
13212	4	Lock nut M14
13213	4	Lock nut M16
13217	8	Lock nut M24
15030	4	Eye bolt M10x30
50601	4	Wire-pulley $\varnothing 75 \times 16$
59015	2	Cover, plastic
77062	1	Transition, elevator/frame
16553	4	Nut M8, black
77138	2	Cylinder bracket
77157	2	Cover bracket right
77158	2	Cover bracket left
77347	2	Hydraulic jack
77404	4	Pulley holder
78428	4	Bolt M14x110
78839	1	Parking brake
79812	2	Bracket plate, front reflector
81094	2	Pressure continuation plug
82000	1	Padlock Yale 50mm Adjustable
77599	8	Clamp

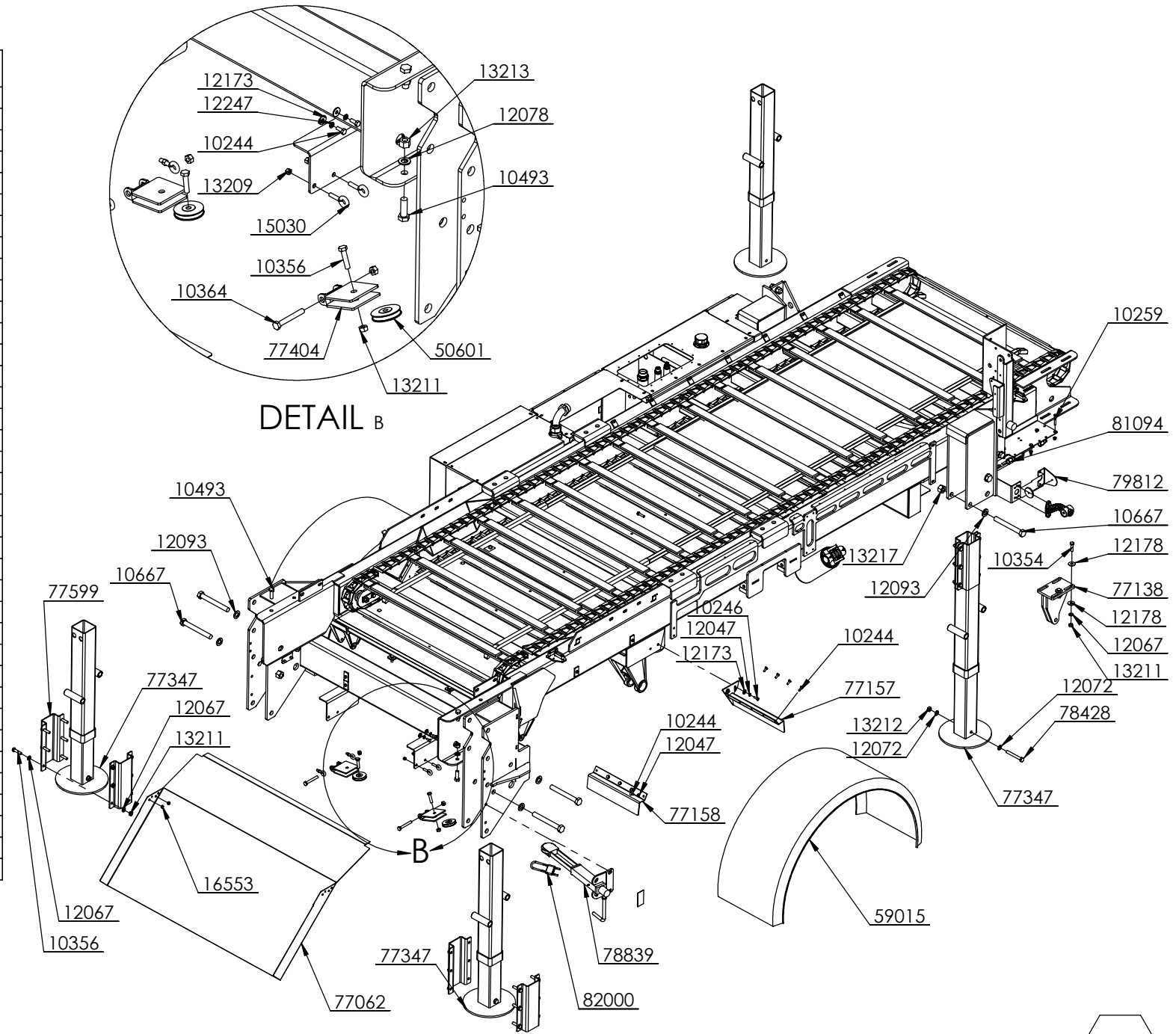

DETAIL B



Part number	Qty	Description
10244	20	Bolt M8 x 20 DIN 933 8.8 FZV
10354	8	Bolt M12 x 45 DIN 931 8.8 FZV
11457	6	Truss-head screw M6x12
11509	8	Countersunk bolt M4x25
12047	44	Washer 8,4 DIN 125A -140HV FZV
12067	68	Washer 13 DIN 125A -140HV FZV
12178	16	Washer 13 x 37 x 3 DIN 9021 FZV
13211	40	Lock nut M12
59015	2	Cover, plastic
59065	1	Level glass
59066	1	Filler cap
59174	2	Fitting 1 1/4" BSP / 1 1/2" BSP
59176	2	Gasket 1 1/4"
59328	2	Fitting 1 1/2"
77138	2	Cylinder bracket
77157	2	Cover bracket right
77158	2	Cover bracket left
79706	1	Hydraulic tank
79743	1	Cover oil cooler
79749	1	Bracket, oil cooler
79793	1	Front bracket, oil cooler
79794	1	Rear bracket, oil cooler
79797	1	Cover above oil cooler
79798	1	Cover above pump
79800	1	Cover, front hydraulic tank
79844	2	Chain link Kohlswa Ewart 78, modified
79845	2	Chain link plate
81199	1	Oil cooler
81310	4	Hultafors Libelle leveller NV 702
81316	8	Spring
81376	1	Thermostat
81623	3	Fan for oil cooler 81199

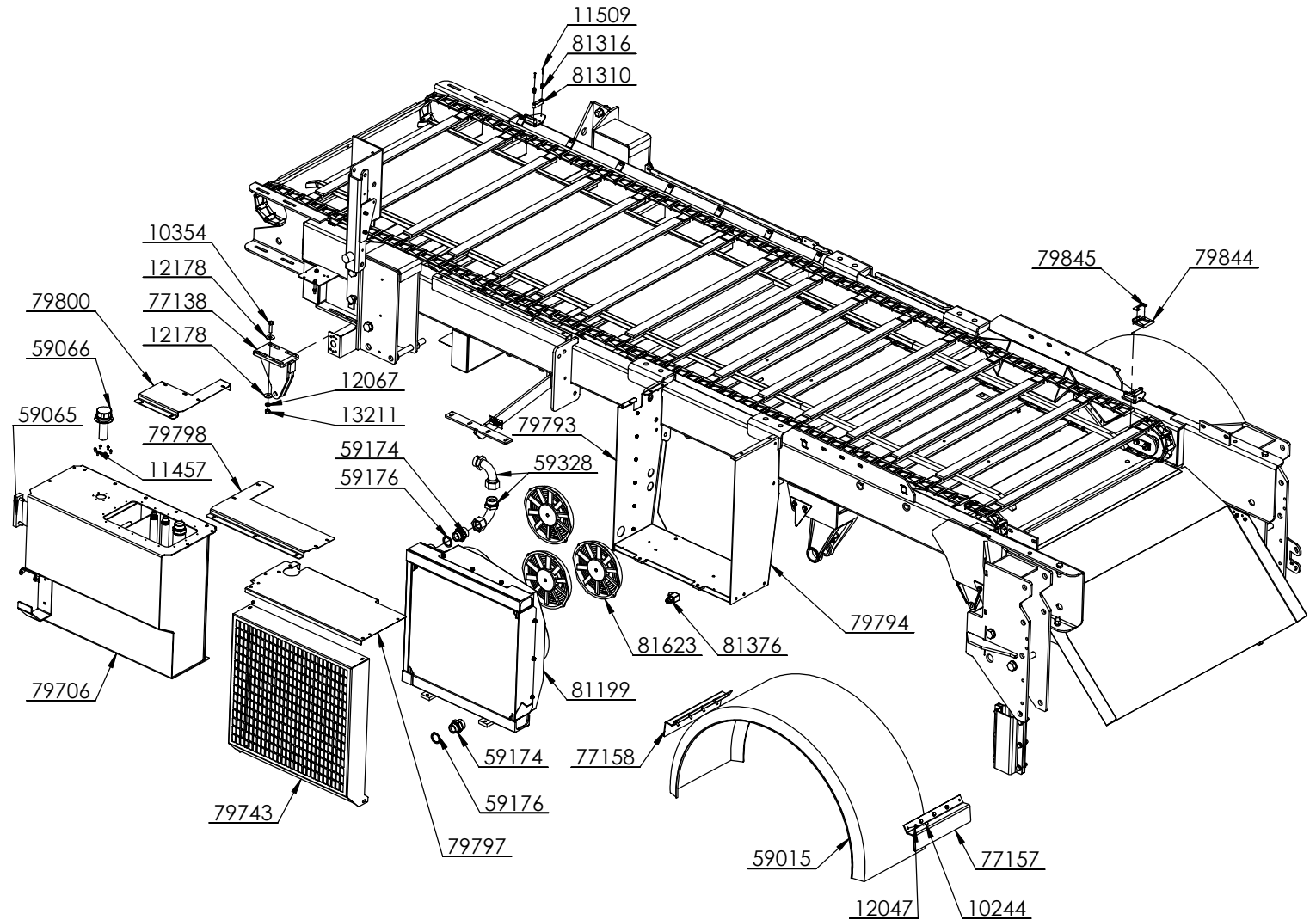

Part number	Qty	Description
10356	28	Bolt M12 x 50 DIN 931 8.8 FZV
10364	4	Bolt M12 x 90 DIN 931 8.8 FZV
10507	3	Bolt M16 x 150 DIN 933 8.8 FZV
12067	68	Washer 13 DIN 125A -140HV FZV
12078	8	Washer 17 DIN 125A -140HV FZV
13013	2	Nut M16 DIN 934
13211	40	Lock nut M12
15607	22	Washer M8, rust free
50601	4	Wire-pulley $\varnothing 75 \times 16$
13209	1	Lock nut M8
77404	4	Pulley holder
78930	1	Bracket, parking brake
15935	2	Welding plate for plastic tube clamp
78931	2	Clamp plate, bracket, parking brake
78981	1	Double tee-connection
77230	4	Chamber support bracket
79790	1	Support rod

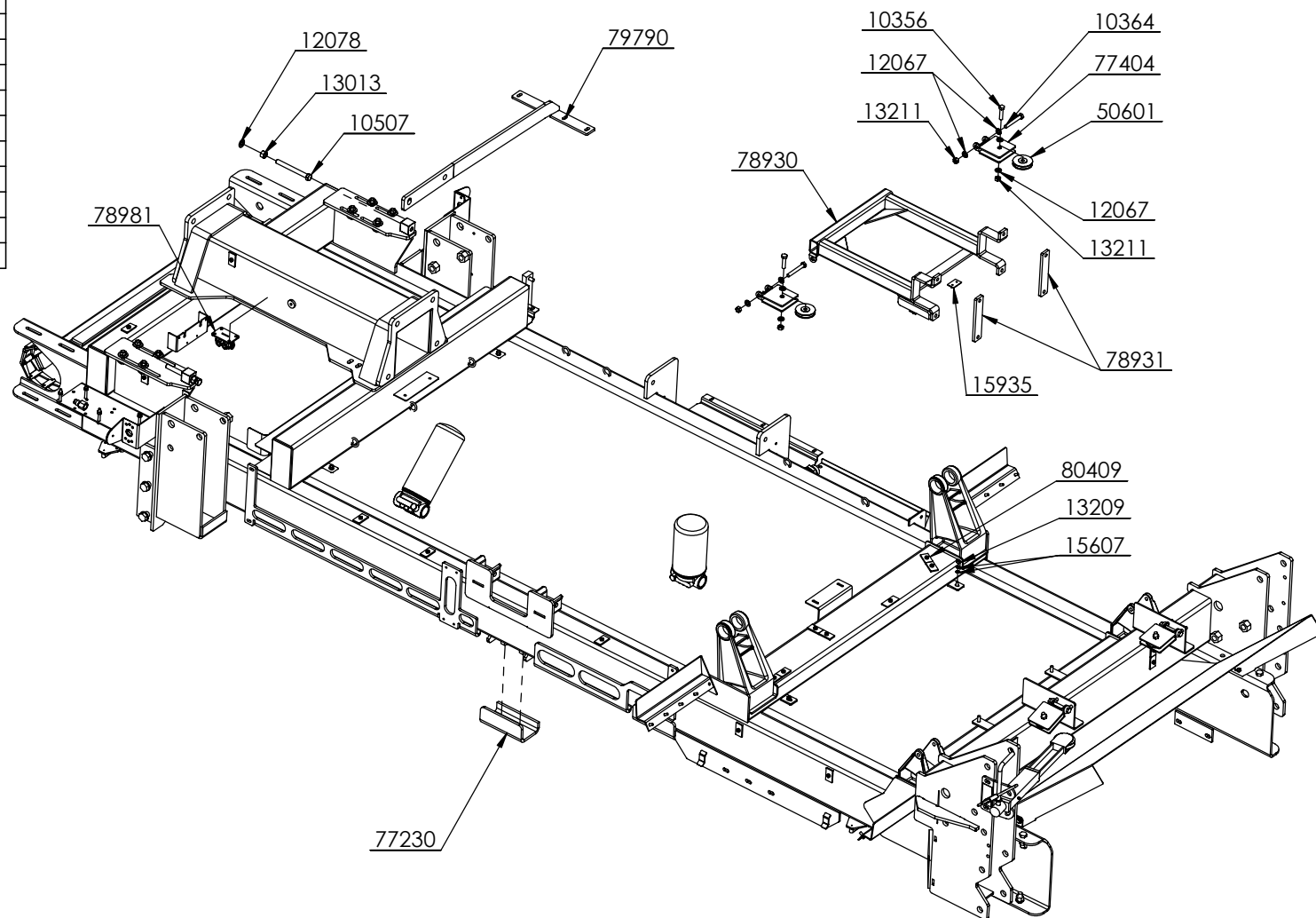

Part number	Qty	Description
10346	2	Bolt M12 x 25 DIN 933 8.8 FZV
11101	4	Bolt M8x40 DIN 603 A4 80
11116	12	Bolt M8x25 DIN 603 A4 80
12067	68	Washer 13 DIN 125A -140HV FZV
12078	8	Washer 17 DIN 125A -140HV FZV
14004	2	Grease nipple M6x1
50015	204	Chain link Kohlswa Ewart 78
59026	4	Bearing 6206 2RS
59082	2	Sprocket, impeller
77186	1	Tray, stainless steel, front
77237	34	Carrier
77633	2	Rubber, scraper, belt under
77639	2	Bolt, chain sprocket
77640	2	Locking, chain sprocket bolt
77641	2	Bolt, locking, sprocket
78697	1	Bottom tray, stainless steel, middle
78698	1	Bottom tray, stainless steel, rear
79742	1	Main frame, DENS-X / Hi-X
80005	1	Plywood board

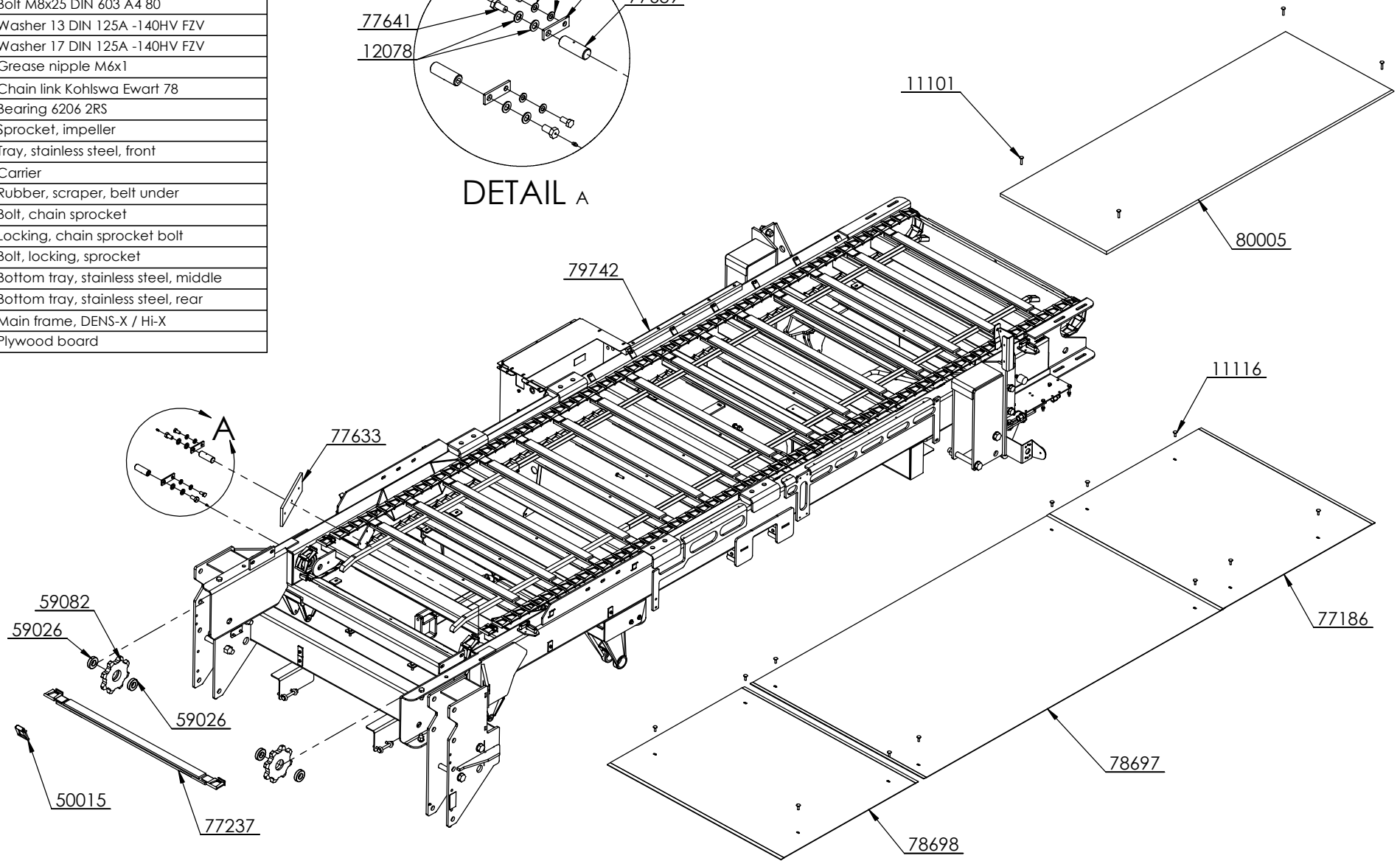
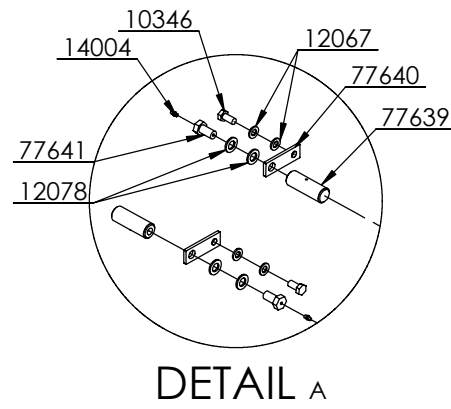

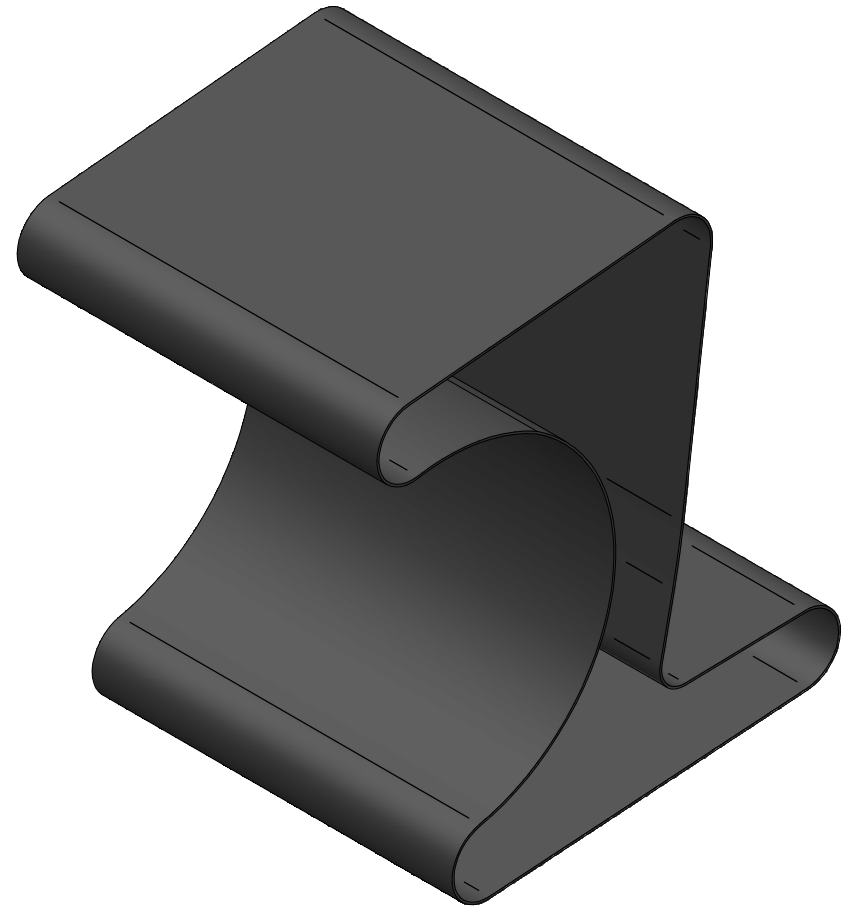
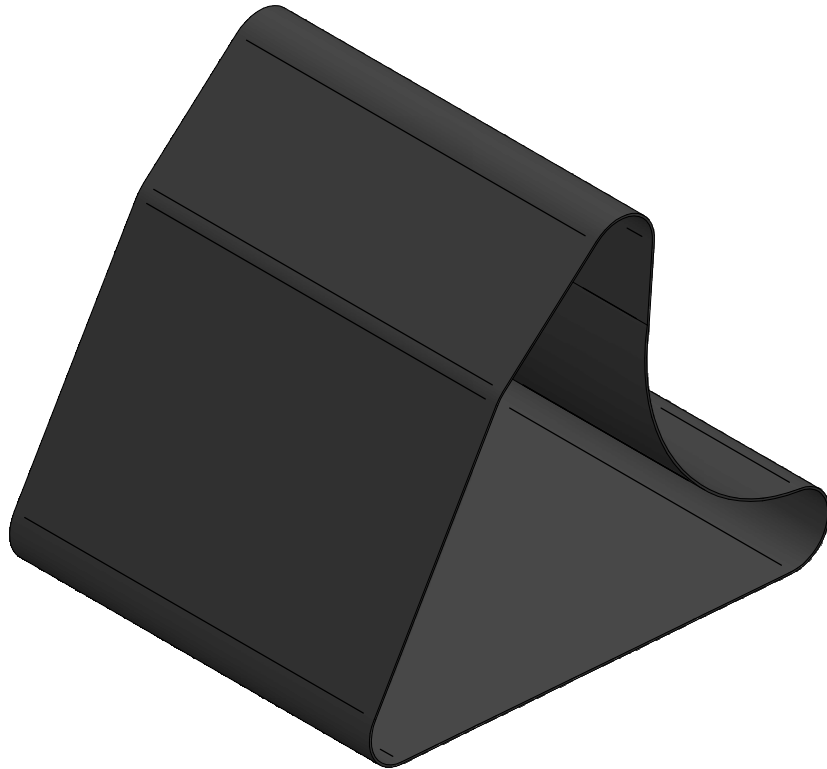

Part Number	Qty.	Title
59655	1	Belt, front chamber, w/lock, EP 500/4 3+1
59656	1	Belt, front chamber, endless, EP 500/4 3+1
59657	1	Belt, rear chamber, w/lock, EP 500/4 3+1
59658	1	Belt, rear chamber, endless, EP 500/4 3+1
59786	1	Alligator clip, mechanical belt lock w/tools (Not shown)

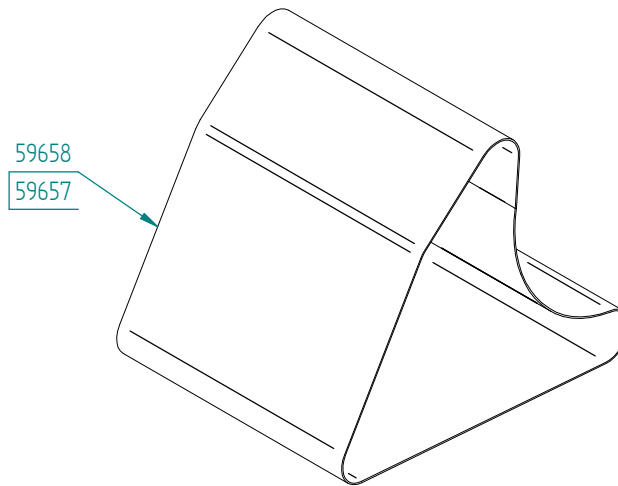
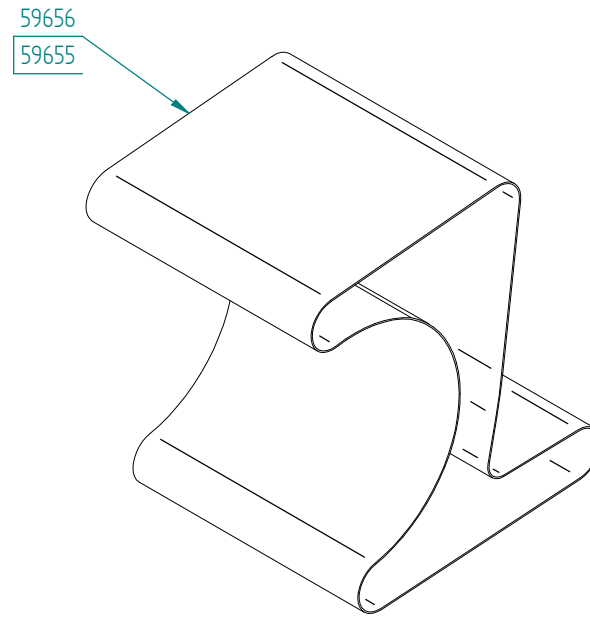

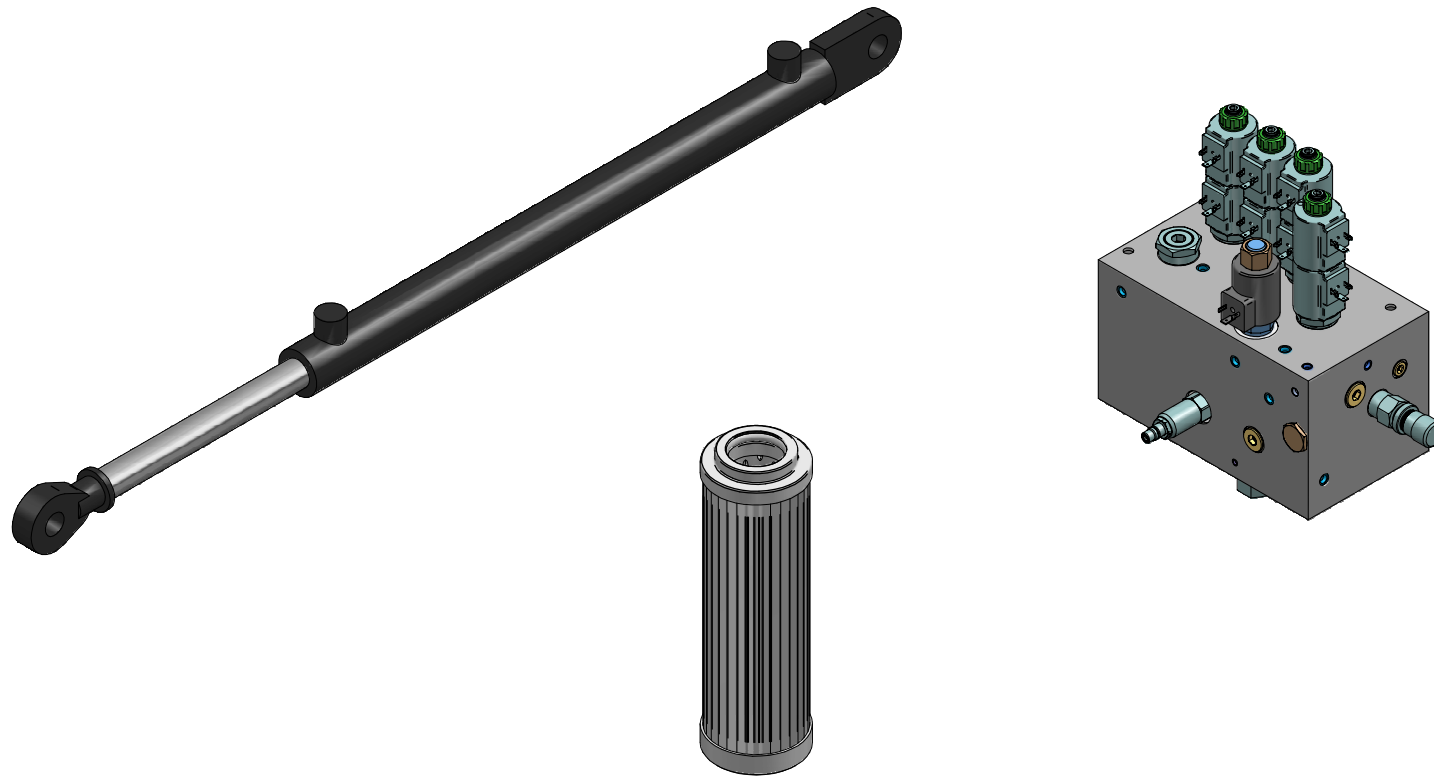

Part Number	Qty.	Title
59078	2	Cylinder 40x25x400
59079	2	Cylinder 50x30x600
59098	2	Cylinder 60x35x800

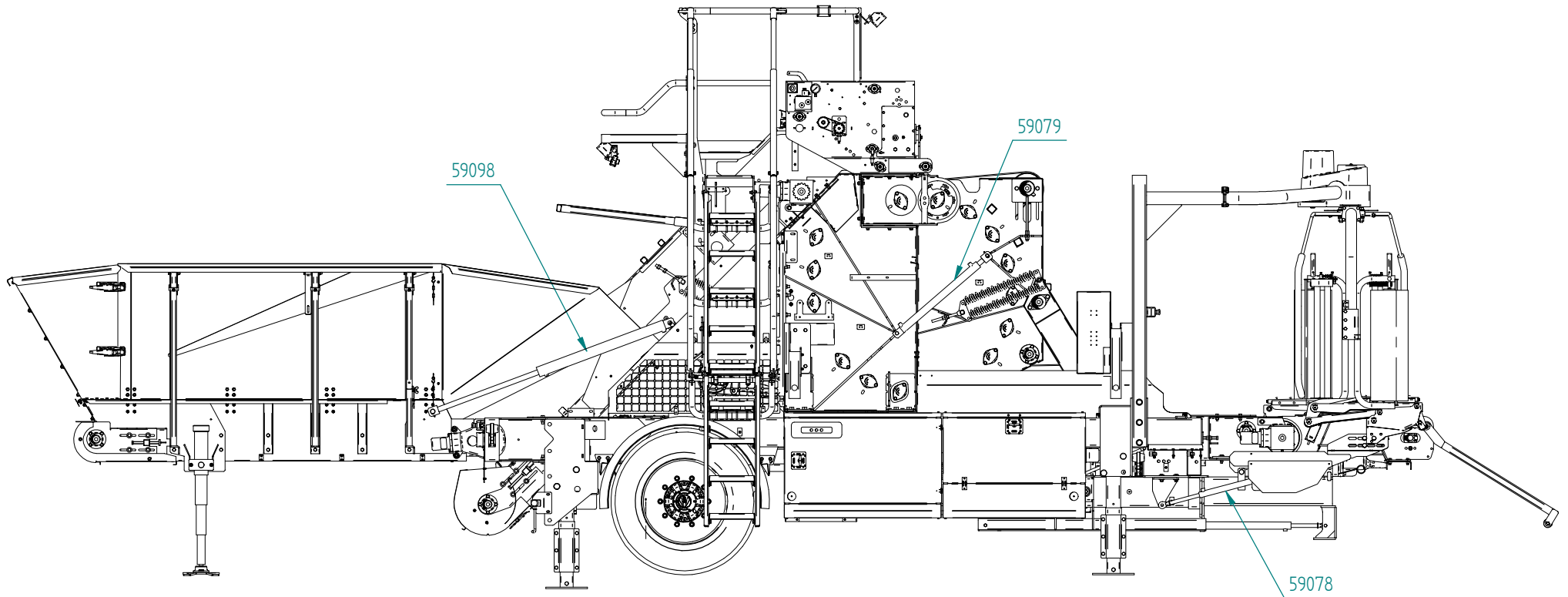

Cylinders
feed hopper
F10

Part Number	Qty.	Title
59381	1	Filter element, pressure
59734	1	Suction filter
59939	1	Filter element, low pressure

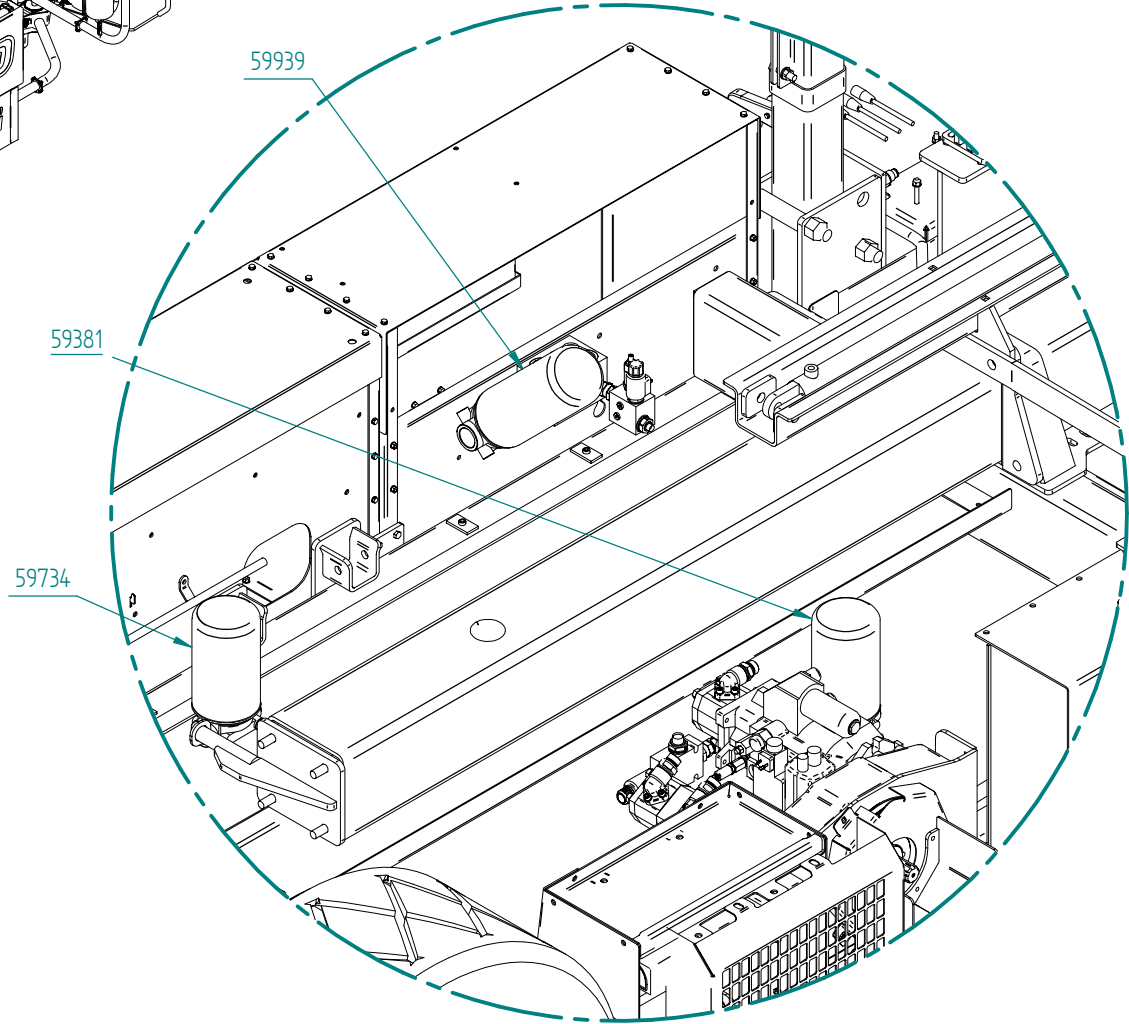
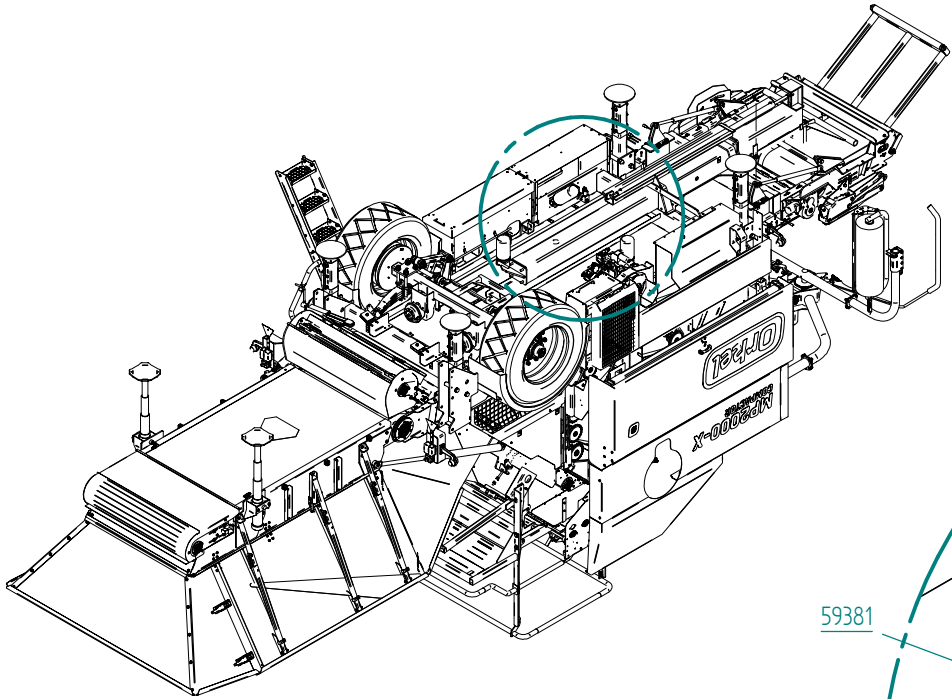

Filters

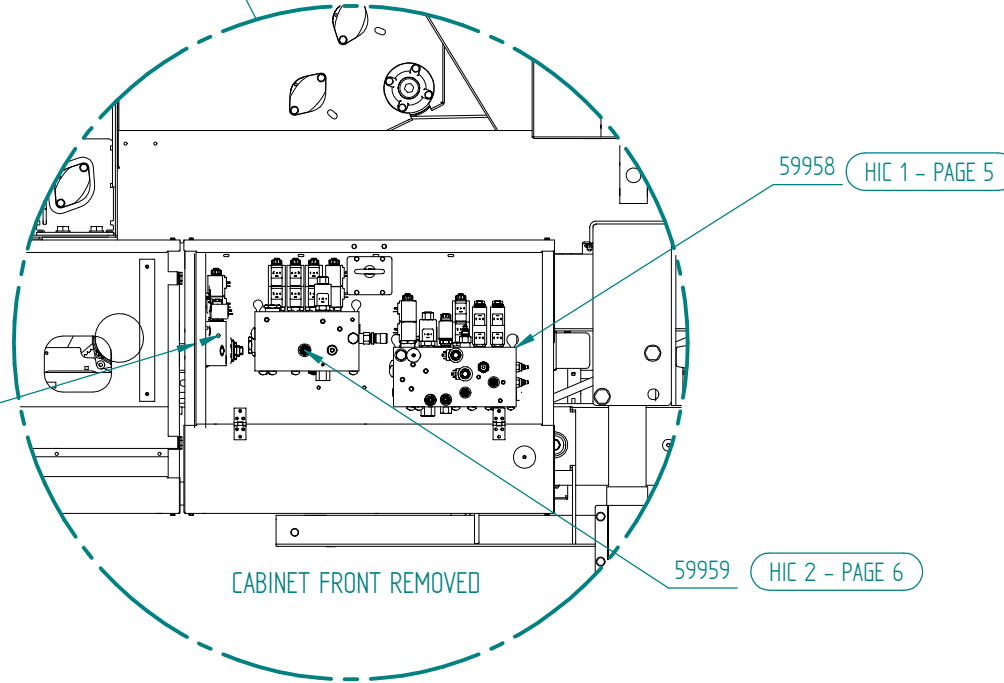
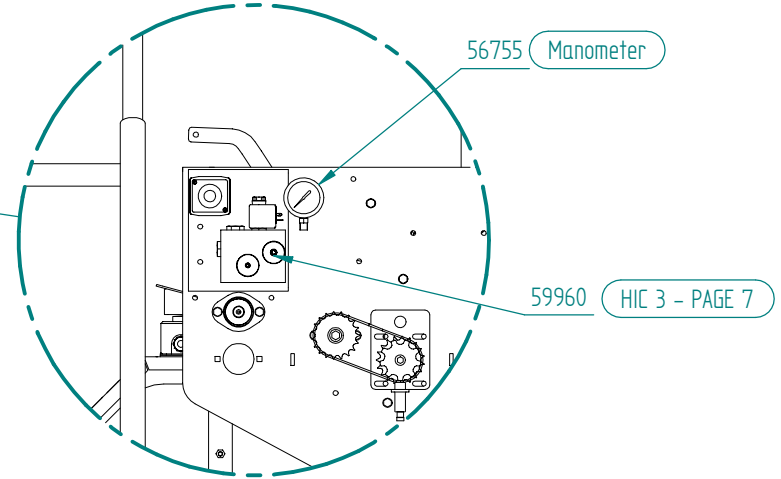
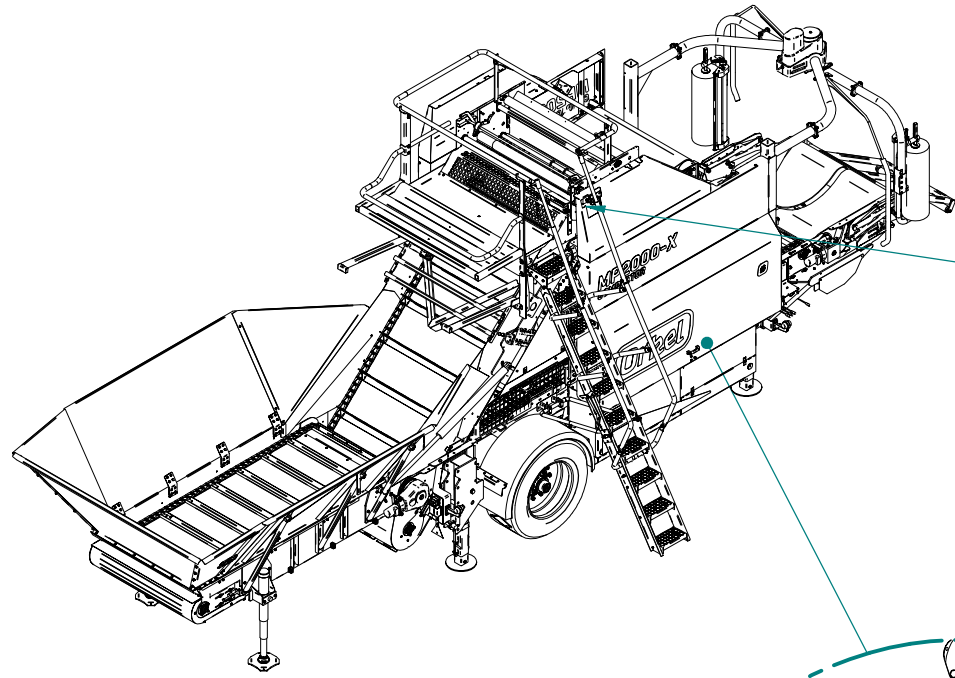

Hydraulic
manifolds

Part Number	Qty.	Title
59958	1	Hydraulic manifold HIC 1 complete
80301	1	Body HIC 1
80305	1	Check valve
80306	2	Check valve, piloted, 90 lpm
80307	4	Check valve, piloted, 35 lpm
80308	1	Compensator, 7 bar, size 10
80309	1	Compensator, 7 bar, size 12
80310	1	Flow control valve 15 lpm
80313	1	Plug 3/8" (inside body)
80314	4	Orifice screw M8x1 (inside body)
80315	1	Plug SAE 10
80316	2	Plug SAE 4
80318	4	Plug SAE 8
80319	1	Proportional valve 40 lpm
80320	1	Proportional valve 60 lpm
80324	2	Poppet valve, NC
80327	1	Poppet valve, NC, one way free flow
80332	1	Relief valve DO 150 bar
80333	1	Relief valve DO 170 bar
80337	1	Spool valve 3-pos, 2T+U
80343	1	Spool valve 3-pos, Y
80344	2	Spool valve 3-pos, Y
80345	1	Coil for PSV10
80346	1	Coil for PSV12
80347	7	Coil for SV10, SVP10, EVK06
80348	4	Coil for SV15
80350	1	Restrictor valve 10 lpm (knob)
80351	4	Restrictor valve 10 lpm (key)

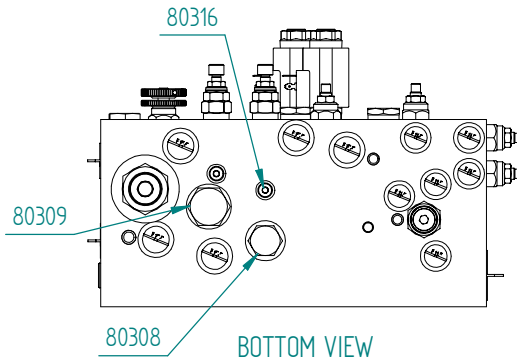

BOTTOM VIEW

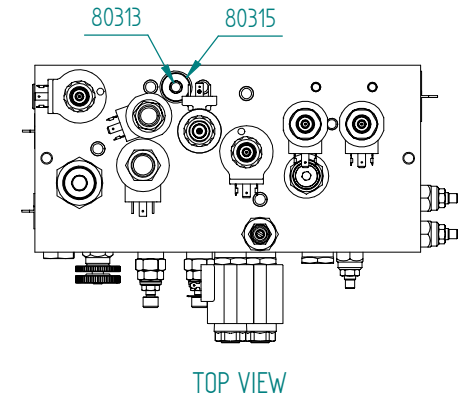

TOP VIEW

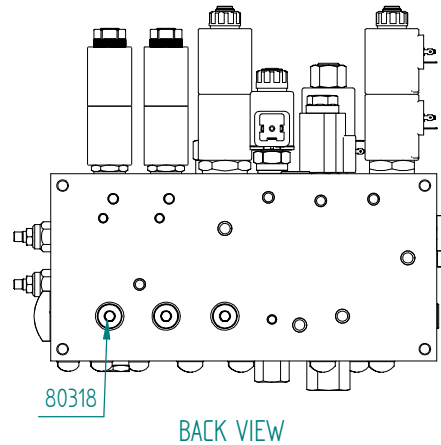

BACK VIEW

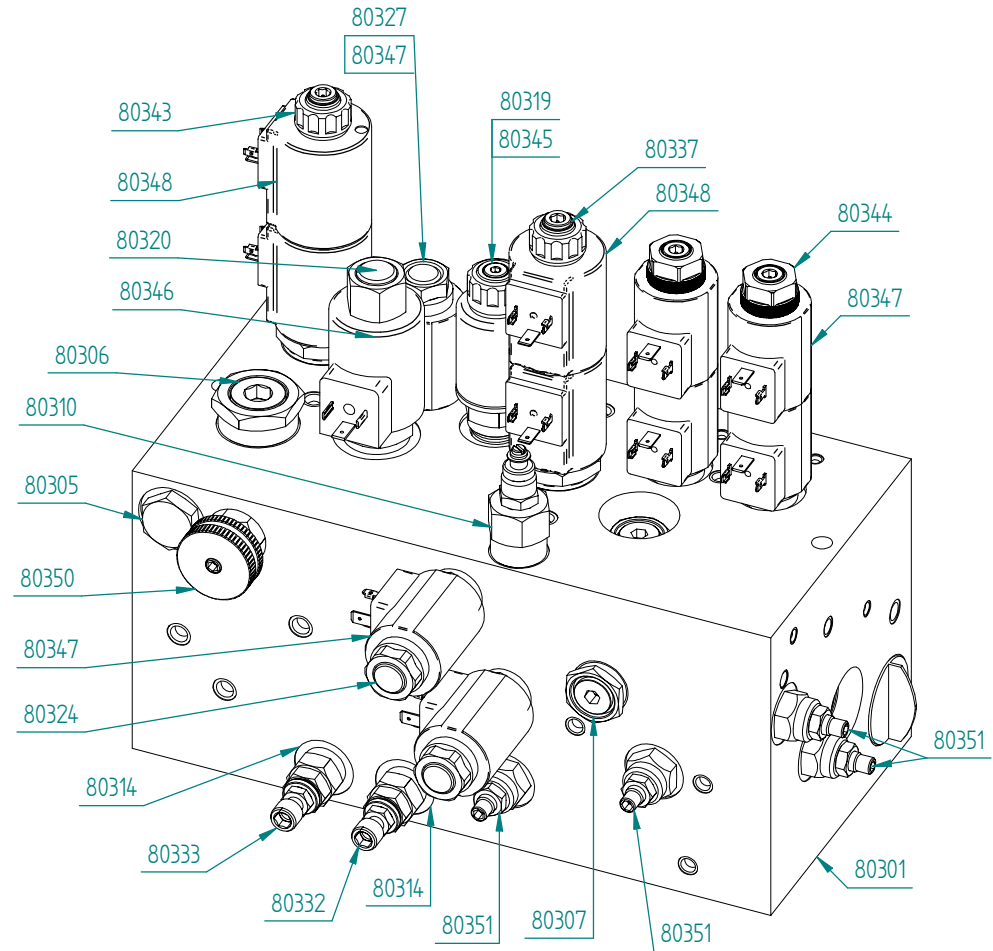

Part Number	Qty.	Title
59959	1	Hydraulic manifold HIC 2 complete
80302	1	Body HIC 2
80306	2	Check valve, piloted, 90 lpm
80309	1	Compensator, 7 bar, size 12
80311	1	Flow control valve 30 lpm
80312	1	Plug 1/2"
80313	1	Plug 3/8" (inside body)
80314	1	Orifice screw M8x1 (inside body)
80315	2	Plug SAE 10
80316	1	Plug SAE 4
80317	2	Plug SAE 6
80320	1	Proportional valve 60 lpm
80328	1	Shuttle valve
80329	1	Relief valve 40-250 bar
80337	2	Spool valve 3-pos, 2T+U
80340	1	Spool valve 3-pos, 4T
80343	1	Spool valve 3-pos, Y
80346	1	Coil for PSV12
80348	8	Coil for SV15

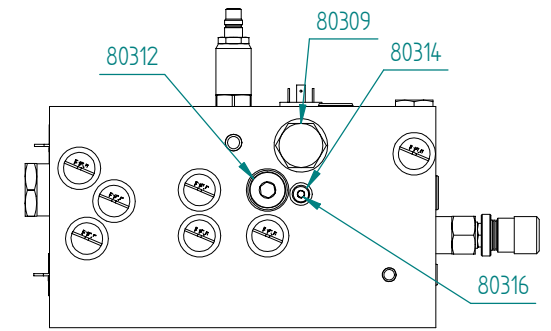

BOTTOM VIEW

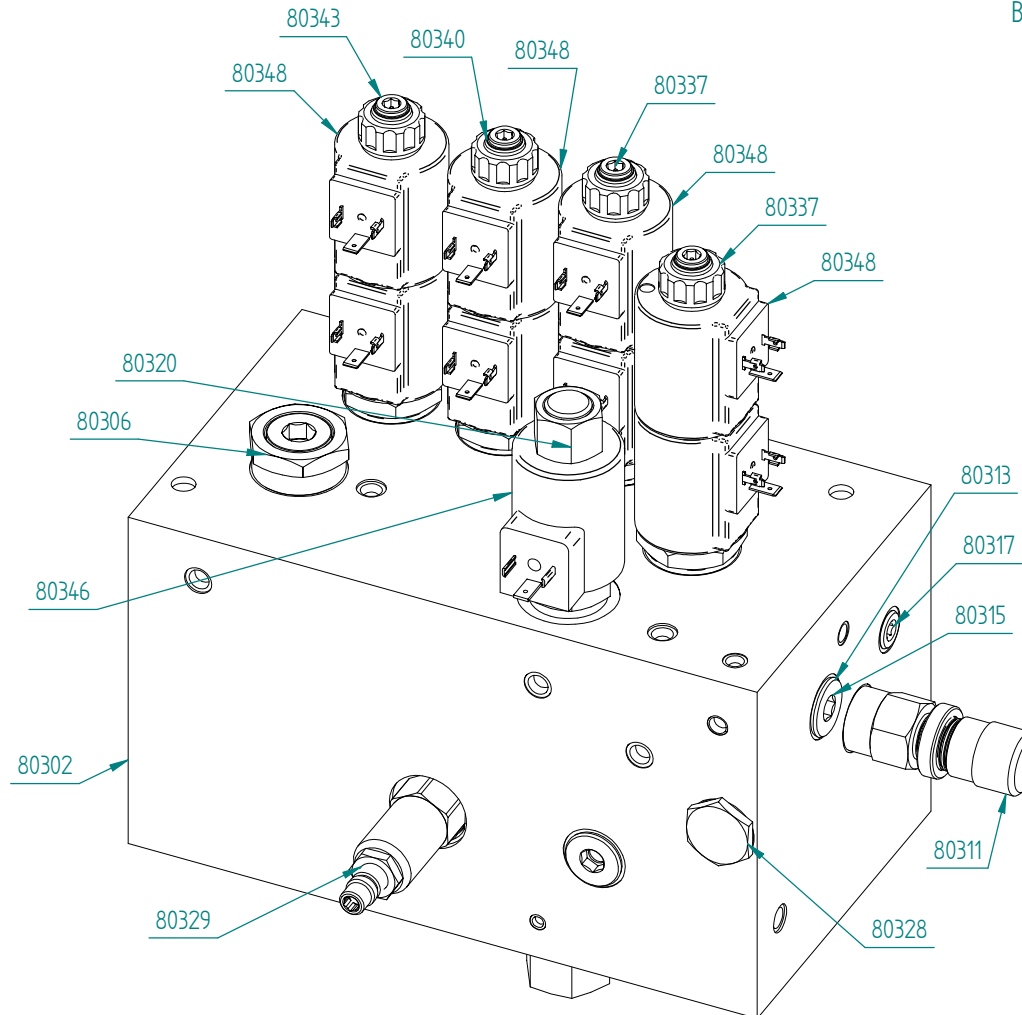

Part Number	Qty.	Title
59960	1	Comatrol HIC3 (net/film system) complete
80303	1	Body HIC 3
80305	2	Check valve
80325	1	Poppet valve, NC
80330	1	Relief valve 7-55 bar
80349	1	Coil for SVP08
80350	1	Restrictor valve 10 lpm (knob)

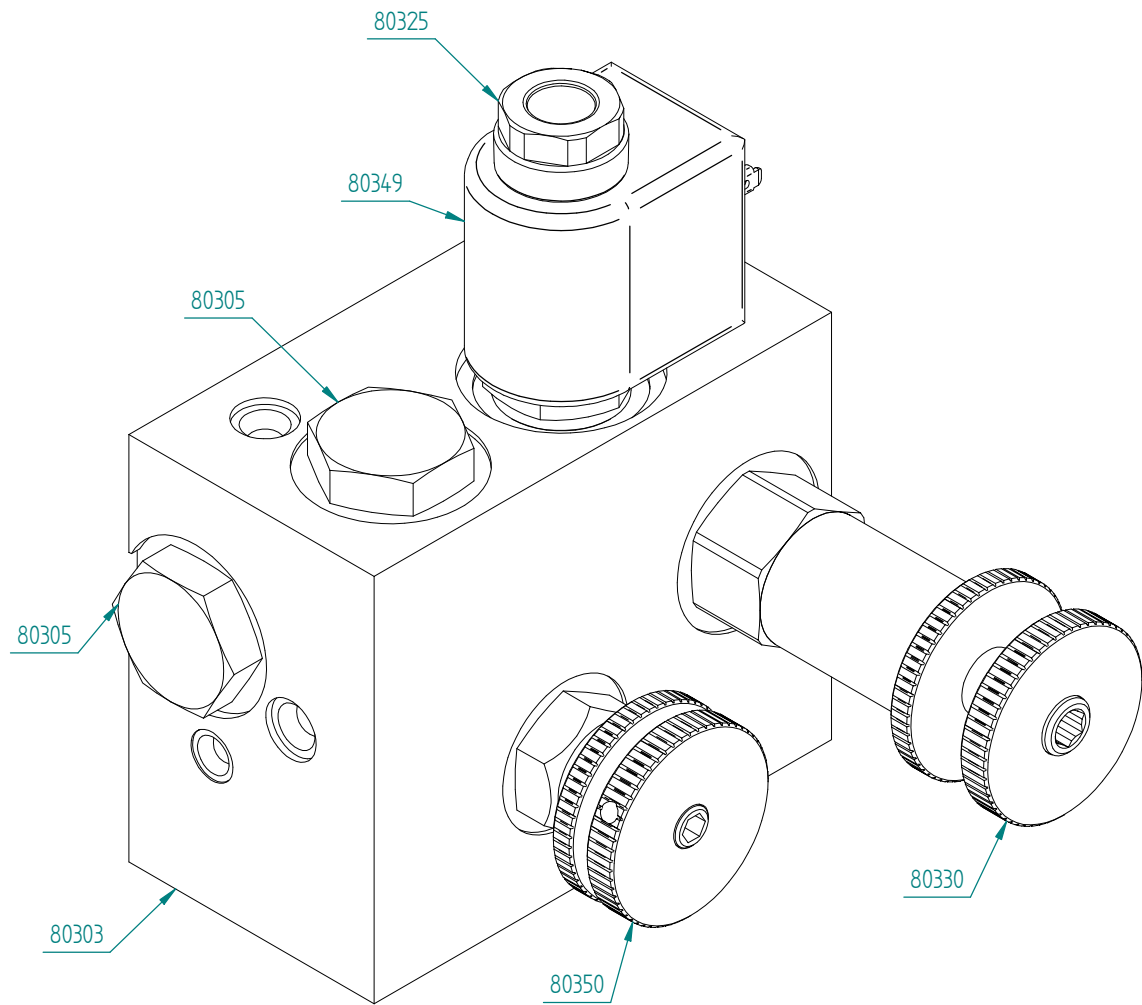

Part Number	Qty.	Title
80175	1	Hydraulic manifold HIC 4 complete
80304	1	Body HIC 4
80305	1	Check valve
80317	1	Plug SAE 6
80318	1	Plug SAE 8
80326	2	Poppet valve, NC, one way free flow
80331	1	Relief valve DO 120 bar
80334	2	Relief valve DO 180 bar
80335	1	Relief valve DO 190 bar
80336	1	Spool valve 2-pos, II
80341	1	Spool valve 3-pos, H
80347	1	Coil for SV10, SVP10, EVK06
80348	2	Coil for SV15
80349	2	Coil for SVP08
80354	1	Restrictor valve 45 lpm (key)

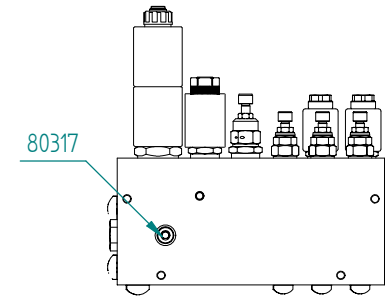

BACK VIEW

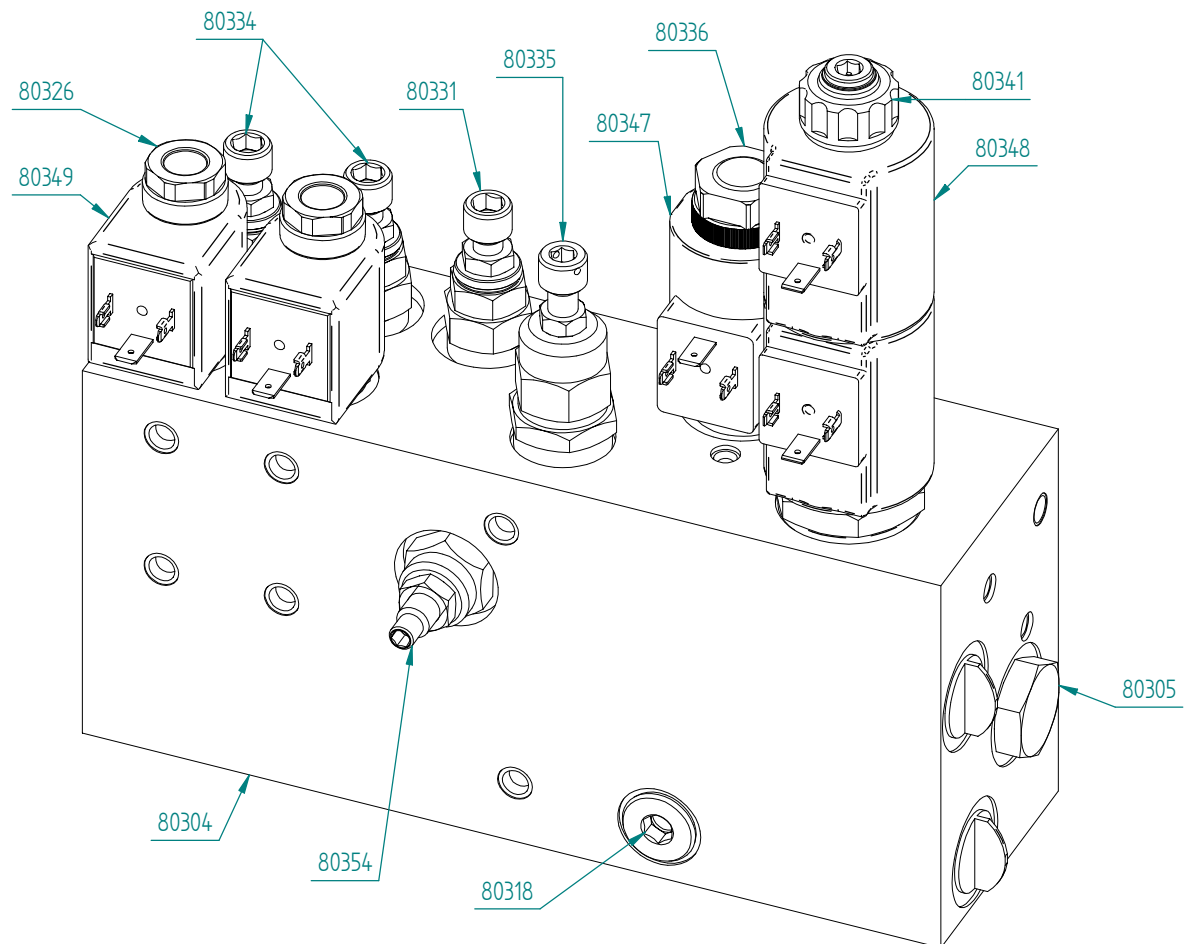

<i>General hydraulic hoses</i>		
Part Number	Qty.	Title
56774	2	Hydraulic hose 3/8" 2SN L=3450 mm
57272	2	Hydraulic hose 3/8" 2SN L=550 mm
59106	1	Hydraulic hose 1/4" 2SN L=2600 mm
59108	2	Hydraulic hose 1/4" 2SN L=3950 mm
59115	1	Hydraulic hose 3/8" 2SN L=1860 mm
59134	1	Hydraulic hose 1/2" 2SN L=1150 mm
59139	1	Hydraulic hose 1/2" 2SN L=800 mm
59143	1	Hydraulic hose 3/8" 2SN L=3610 mm
59291	3	Hydraulic hose 1/4" 2SN L=1190 mm
59540	2	Hydraulic hose 3/8" 2SN L=1240 mm
59628	1	Hydraulic hose 3/8" 2SN L=355 mm
59669	1	Hydraulic hose 3/8" 2SN L=400 mm
59669	1	Hydraulic hose 3/8" 2SN L=400 mm
59670	1	Hydraulic hose 3/8" 2SN L=2800 mm
59672	1	Hydraulic hose 1/4" 2SN L=350 mm
59673	1	Hydraulic hose 1/4" 2SN L=500 mm
59674	2	Hydraulic hose 3/8" 2SN L=850 mm
80117	1	Hydraulic hose 3/4" 1SN L=760 mm
80118	1	Hydraulic hose 3/4" 1SN L=760 mm

<i>General hydraulic hoses</i>		
Part Number	Qty.	Title
80119	1	Hydraulic hose 1/4" 2SN L=4800 mm
80120	1	Hydraulic hose 1 1/2" 1SN L=2450 mm
80121	1	Hydraulic hose 1 1/2" 1SN L=740 mm
80124	1	Hydraulic hose 3/8" 2SN L=1550 mm
80125	1	Hydraulic hose 1/4" 2SN L=2650 mm
80126	1	Hydraulic hose 1/4" 2SN L=580 mm
80128	1	Hydraulic hose 3/8" 2SN L=2060 mm
80129	1	Hydraulic hose 1/4" 2SN L=5000 mm
80130	1	Hydraulic hose 1/4" 2SN L=4890 mm
80132	2	Hydraulic hose 1/4" 2SN L=1330 mm
80133	2	Hydraulic hose 1/4" 2SN L=1860 mm
80134	1	Hydraulic hose 1/2" 2SN L=3970 mm
80135	1	Hydraulic hose 1/2" 2SN L=3600 mm
80136	2	Hydraulic hose 1/4" 2SN L=1400 mm
80137	1	Hydraulic hose 1/4" 2SN L=1600 mm
80141	1	Hydraulic hose 1/4" 2SN L=3500 mm
80142	2	Hydraulic hose 3/8" 2SN L=2950 mm
80144	1	Hydraulic hose 3/8" 2SN L=3230 mm
80145	1	Hydraulic hose 3/8" 2SN L=3020 mm
80146	1	Hydraulic hose 3/8" 2SN L=3220 mm

<i>General hydraulic hoses</i>		
Part Number	Qty.	Title
80147	1	Hydraulic hose 3/8" 2SN L=650 mm
80148	1	Hydraulic hose 3/8" 2SN L=3010 mm
80149	2	Hydraulic hose 1/4" 2SN L=2850 mm
80150	2	Hydraulic hose 1/4" 2SN L=3790 mm
80151	1	Hydraulic hose 3/8" 2SN L=480 mm
80803	1	Hydraulic hose 3/4" 1SN L=600 mm
80820	2	Hydraulic hose 3/8" 2SN L=3560 mm
80824	2	Hydraulic hose 1/4" 2SN L=2640 mm
80836	1	Hydraulic hose 1/4" 2SN L=1430 mm
80856	1	Hydraulic hose 3/8" 2SN L=2650 mm
80857	1	Hydraulic hose 3/8" 2SN L=1850 mm
80858	1	Hydraulic hose 3/8" 2SN L=570 mm
80860	2	Hydraulic hose 3/8" 2SN L=1300 mm
80864	2	Hydraulic hose 1" 4SH L=1460 mm
80873	2	Hydraulic hose 3/8" 2SN L=1350 mm
80874	2	Hydraulic hose 1/4" 2SN L=1750 mm
80875	1	Hydraulic hose 3/8" 2SN L=1430 mm
80876	1	Hydraulic hose 1/4" 2SN L=3430 mm
80934	1	Hydraulic hose 1/2" 2SN L=2570 mm
80935	1	Hydraulic hose 3/8" 2SN L=1330 mm



All hydraulic hoses are marked with part number

<i>Hydraulic hoses for feed hopper F10</i>		
Part Number	Qty.	Title
59281	1	Hydraulic hose 3/8" 2SN L=4360 mm
59282	1	Hydraulic hose 3/8" 2SN L=4465 mm
80917	2	Hydraulic hose 1/4" 2SN L=3400 mm
80918	1	Hydraulic hose 1/4" 2SN L=2300 mm
80919	1	Hydraulic hose 1/4" 2SN L=2760 mm
80920	1	Hydraulic hose 1/4" 2SN L=3900 mm
80921	1	Hydraulic hose 1/4" 2SN L=4400 mm

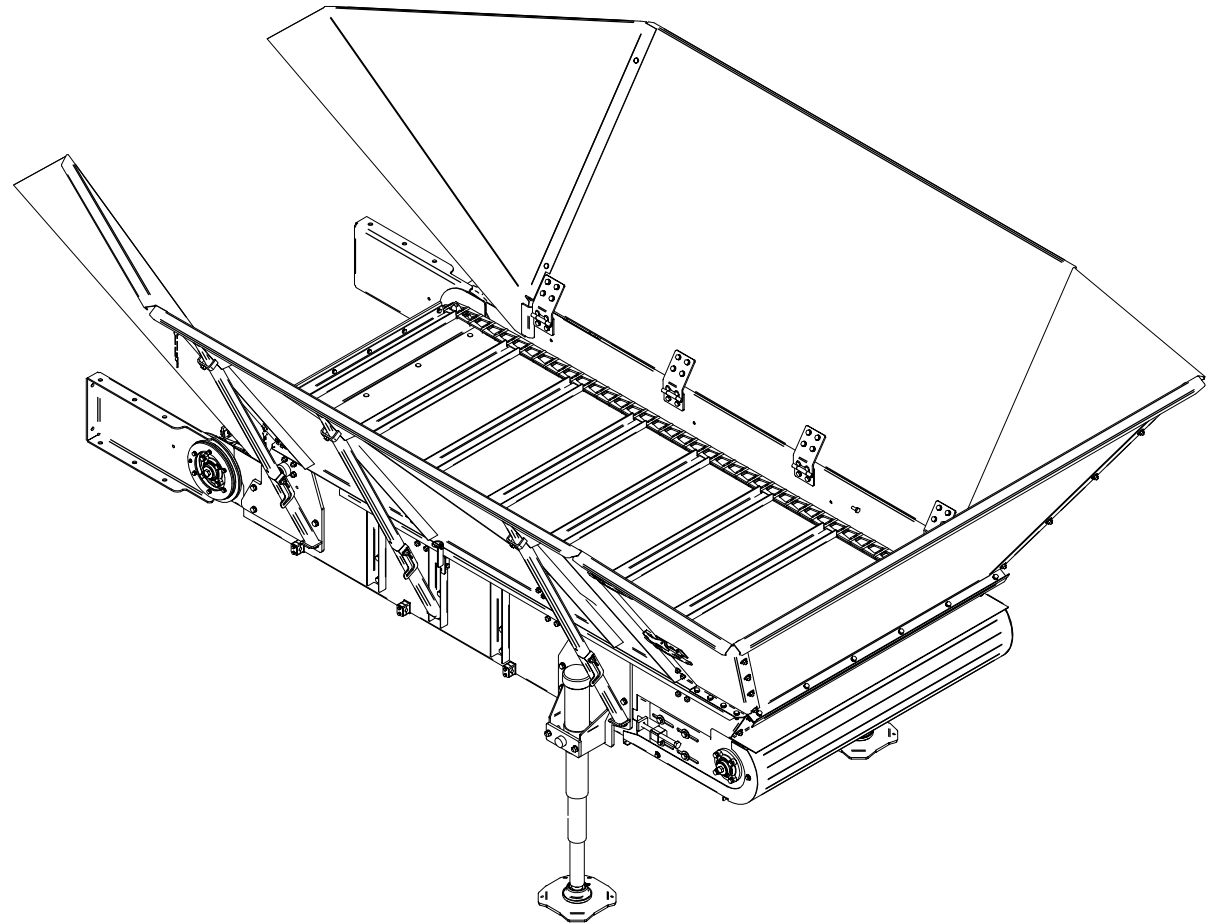

Hydraulic hoses

All hydraulic hoses are marked with part number

<i>Hydraulic hoses for transport drawbar</i>		
Part Number	Qty.	Title
59308	2	Hydraulic hose 1/4" 2SN L=2450 mm
59665	1	Hydraulic hose 3/8" 2SN L=7500 mm
59666	1	Hydraulic hose 3/8" 2SN L=7300 mm
80659	3	Hydraulic hose 1/2" 2SN L=2170 mm
80871	2	Hydraulic hose 1" 4SH L=620 mm
80872	1	Hydraulic hose 3/4" 1SN L=580 mm
80901	1	Hydraulic hose 1 1/4" 1SN L=770 mm
80922	1	Hydraulic hose 1/4" 2SN L=885 mm

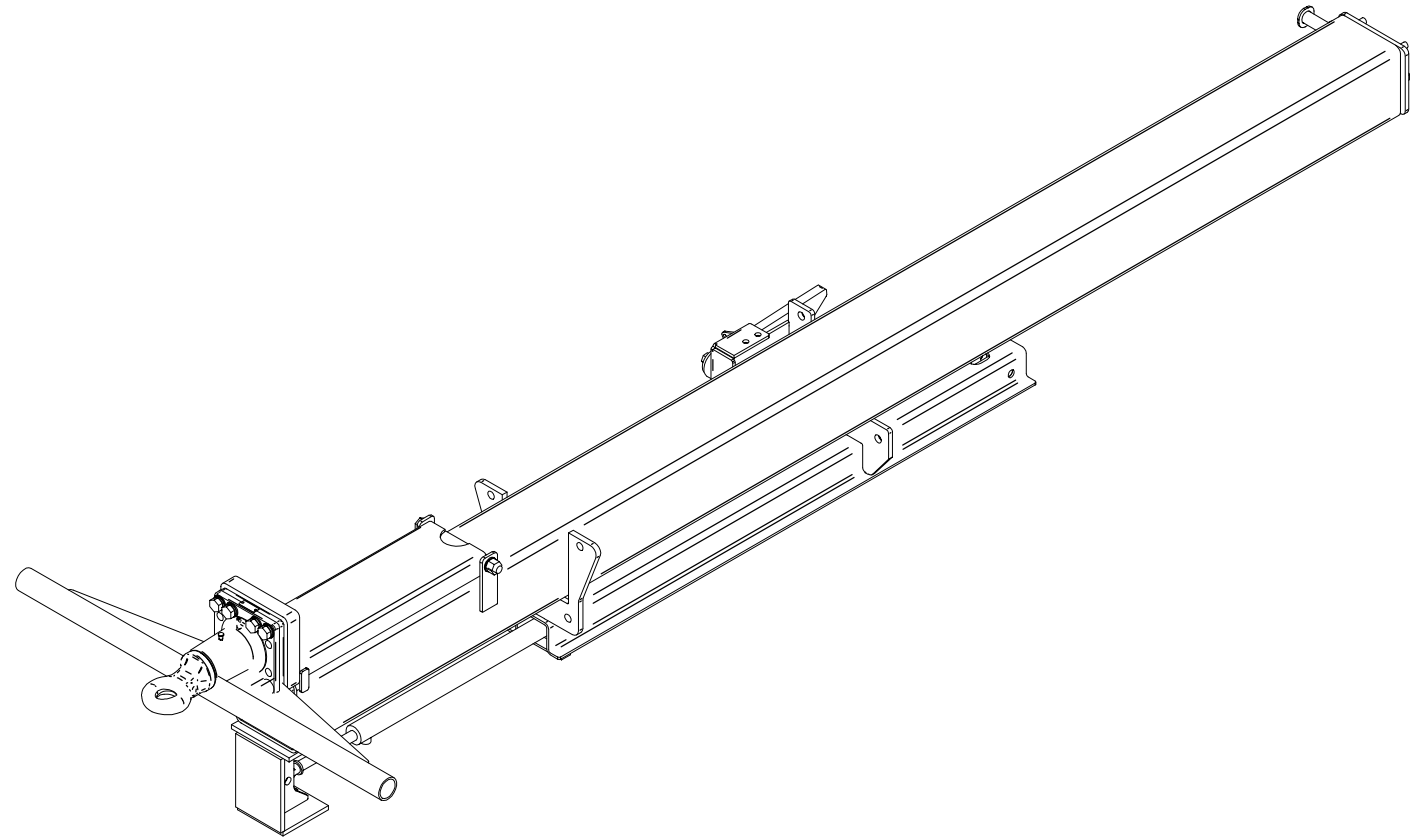

Hydraulic hoses

All hydraulic hoses are marked with part number

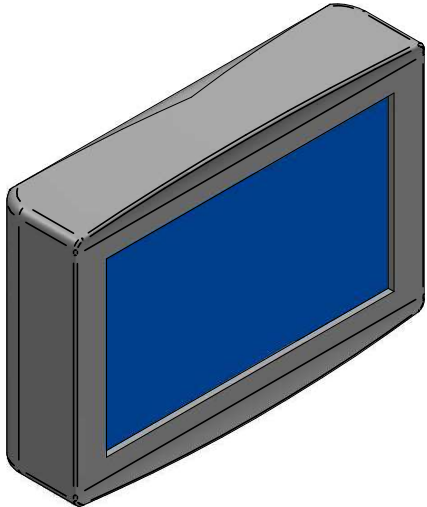
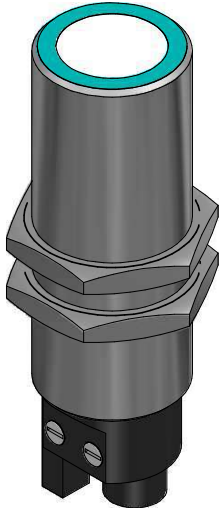
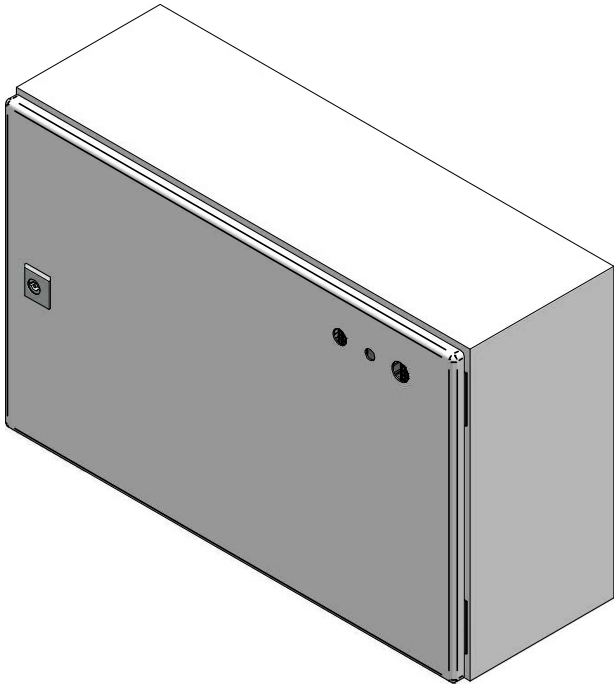

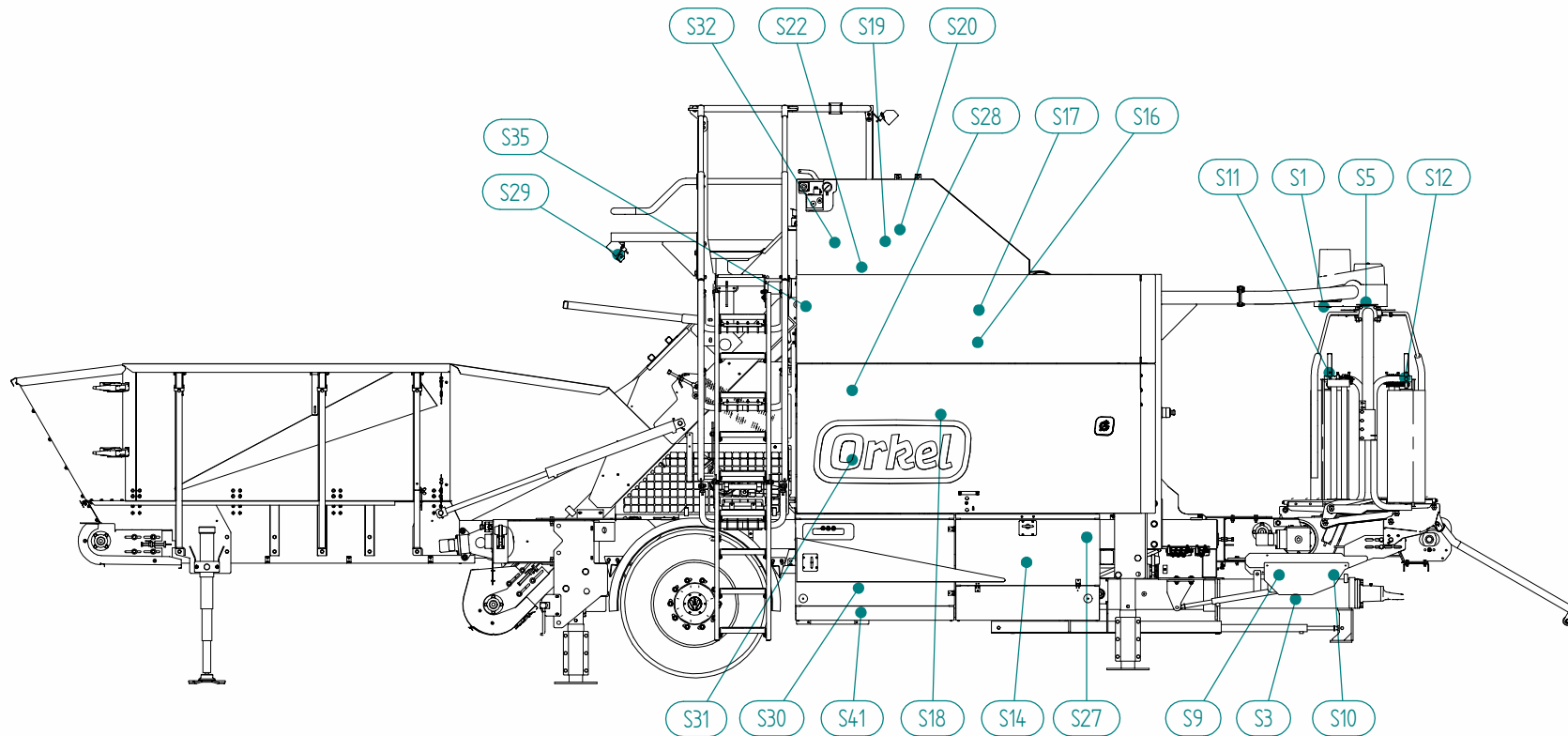

Sensors

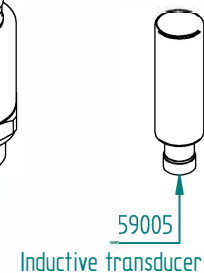
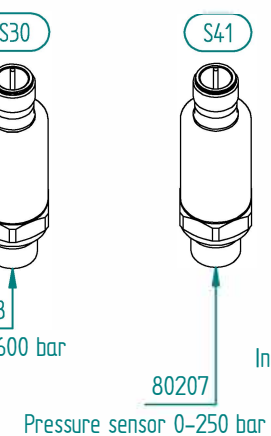
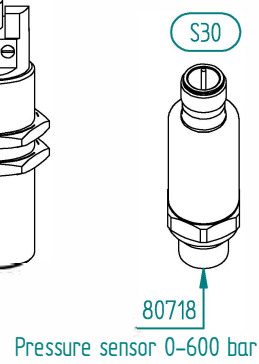
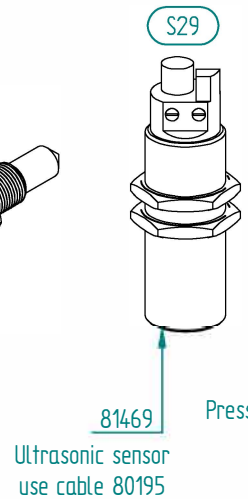
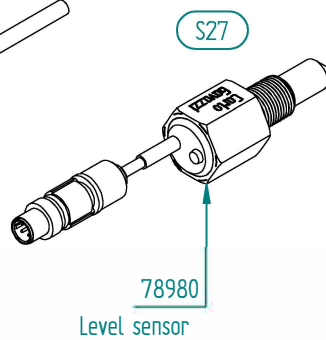
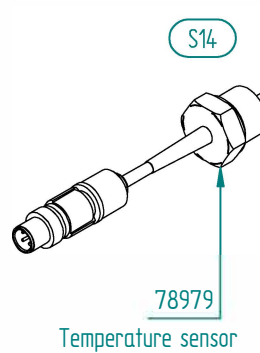
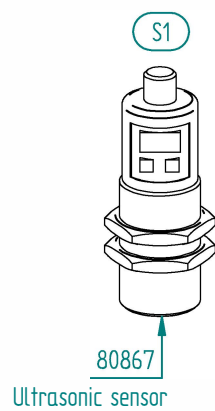

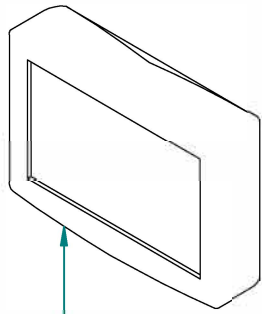

59985 Display unit

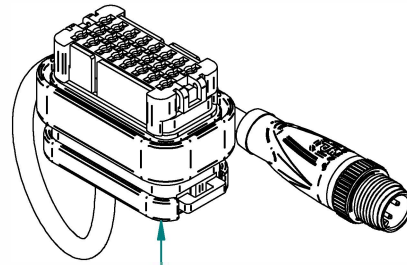

80733 Adapter cable AMPSEAL - M12

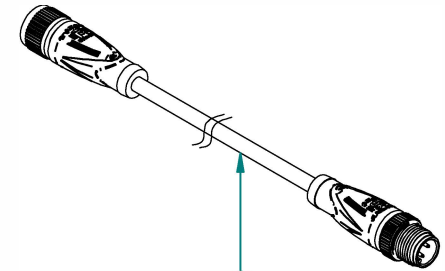

81306 Connection cable, 5 meter

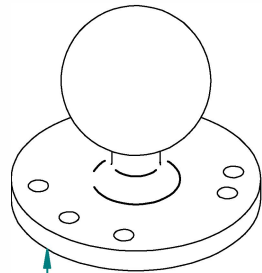

80505 RAM-fastener, foot

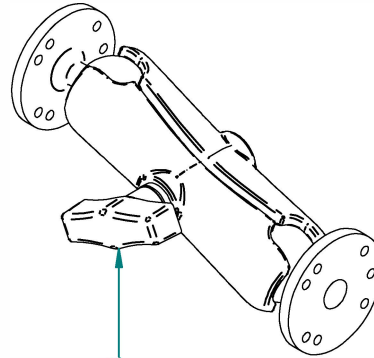

80504 RAM-fastener, complete

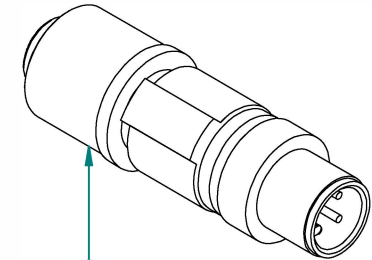

80202 M12-contact Quickon

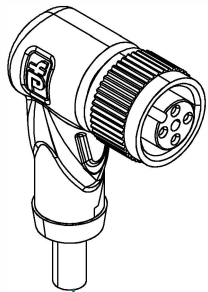

59007 Sensor cable

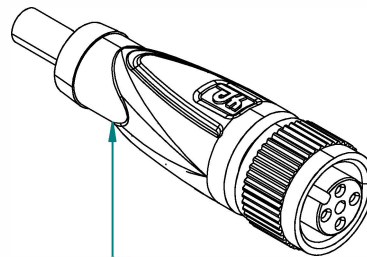

80195 Cable 5-lead for sensor 81469

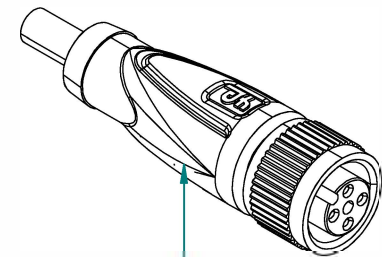

59006 Sensor cable 4-lead

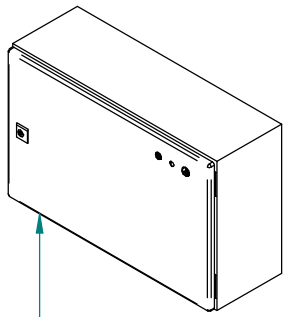

80107 Cabinet for control system, complete

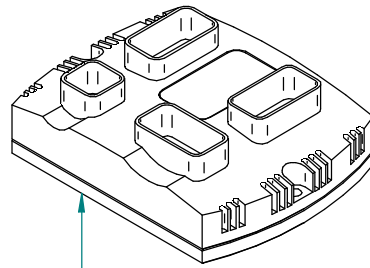

59943 Control unit

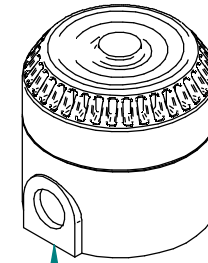

80115 Siren

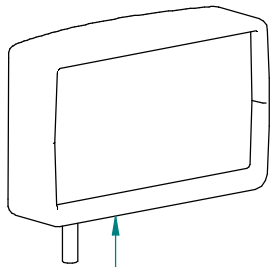

59581 Flood light

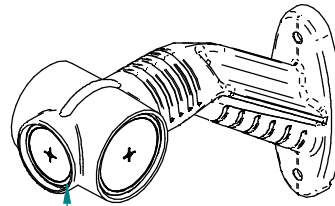

81038 Marker light, left LED

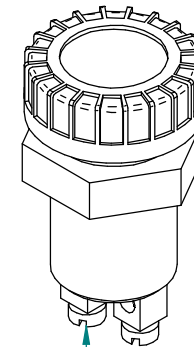

59984 Charging indicator lamp

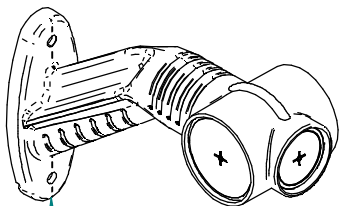

81039 Marker light, right LED

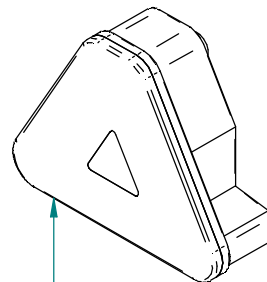

81037 Agripoint Full LED 5 pin connector

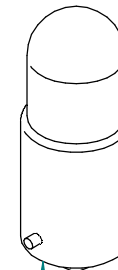

80113 Light bulb 24V 4W

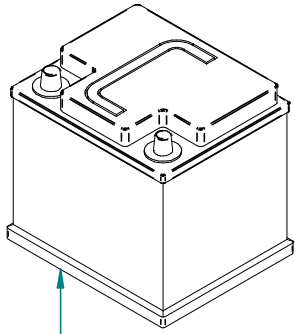

59949 Battery 12V 44Ah

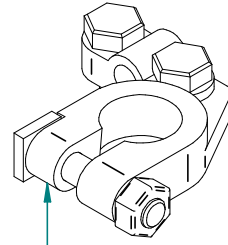

80063 Battery terminal shoe, minus

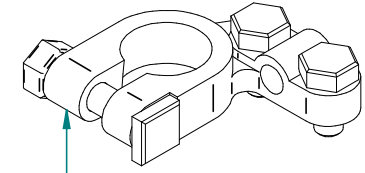

80064 Battery terminal shoe, plus

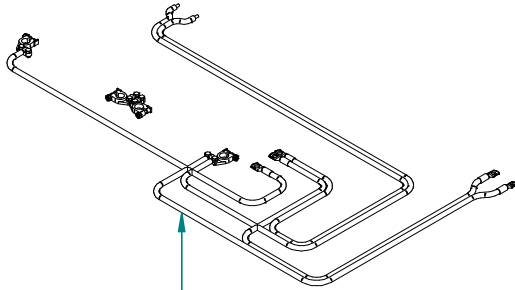

80066 Battery bridge cable

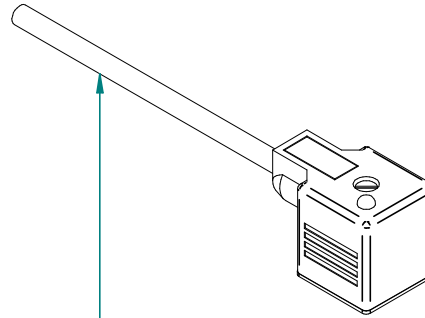

59310 Valve cable with diode, 3 meter

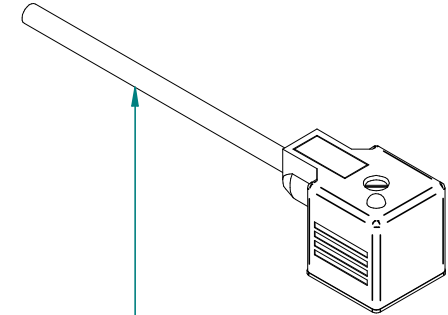

80885 Valve cable with diode, 5 meter

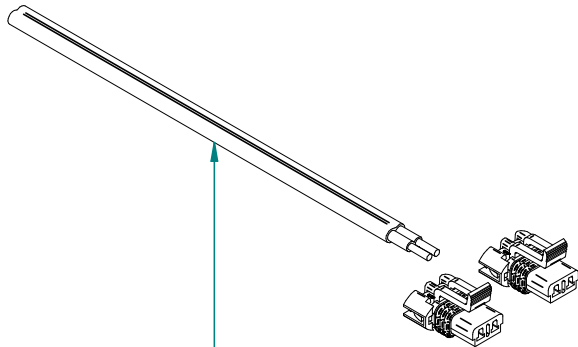

78166 Cable for cooling fan

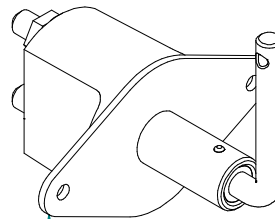

81074 Main power switch

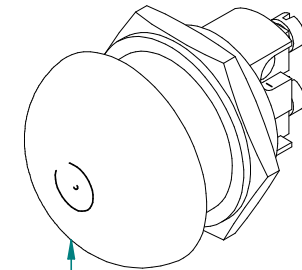

59045 Switch

Part Number	Qty.	Title
81037	2	Agripoint full LED 5 pin connector
81038	2	Marker light, left LED
81306	1	Connection cable, 5 meter
59005	11	Inductive transducer
59006	11	Sensor cable 4-lead
59007	6	Sensor cable
59045	3	Switch
81039	2	Marker light, right LED
59310	22	Valve cable with diode, 3 meter
59581	2	Flood light
59943	2	Control unit
59949	2	Battery 12V 44Ah
81469	1	Ultrasonic sensor
59984	1	Charging indicator lamp
59985	1	Display unit
78166	1	Cable for cooling fan
78979	1	Temperature sensor
78980	1	Level sensor
80063	2	Battery terminal shoe, minus
80064	2	Battery terminal shoe, plus
80066	1	Battery bridge cable
80107	1	Electric cabinet, complete
80113	1	Light bulb 24V 4W

Part Number	Qty.	Title
80115	1	Siren
80195	1	Cable 5-lead
80202	1	M12-contact Quickon
80207	1	Pressure sensor 0-250 bar
80504	1	RAM-fastener, complete
80505	1	RAM-fastener, foot
80718	1	Pressure sensor 0-600 bar
80733	1	Adapter cable AMPSEAL - M12
80867	1	Ultrasonic sensor
80885	2	Valve cable with diode, 5 meter
81074	1	Main power switch

Telescopic drawbar & PTO shaft

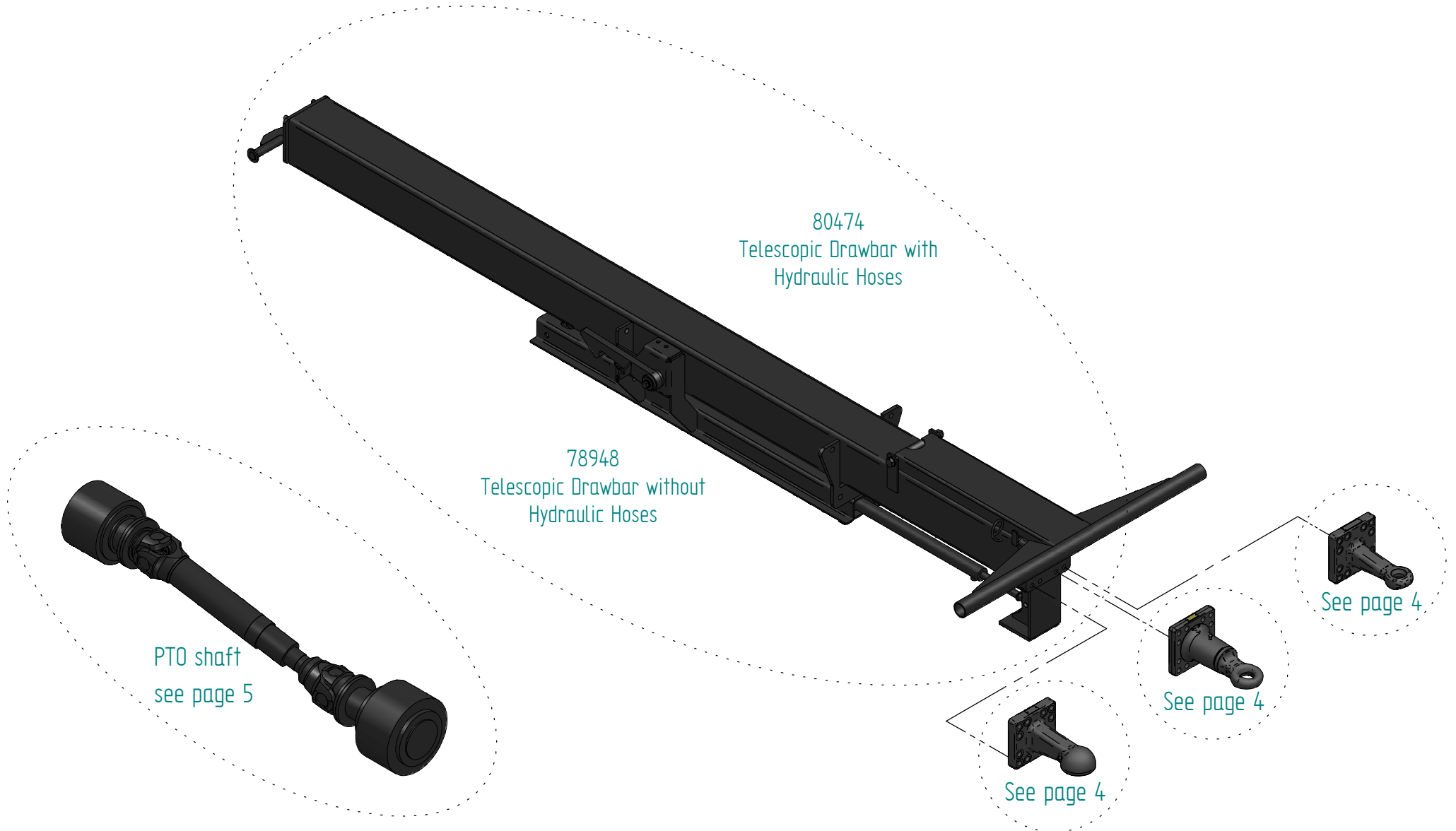

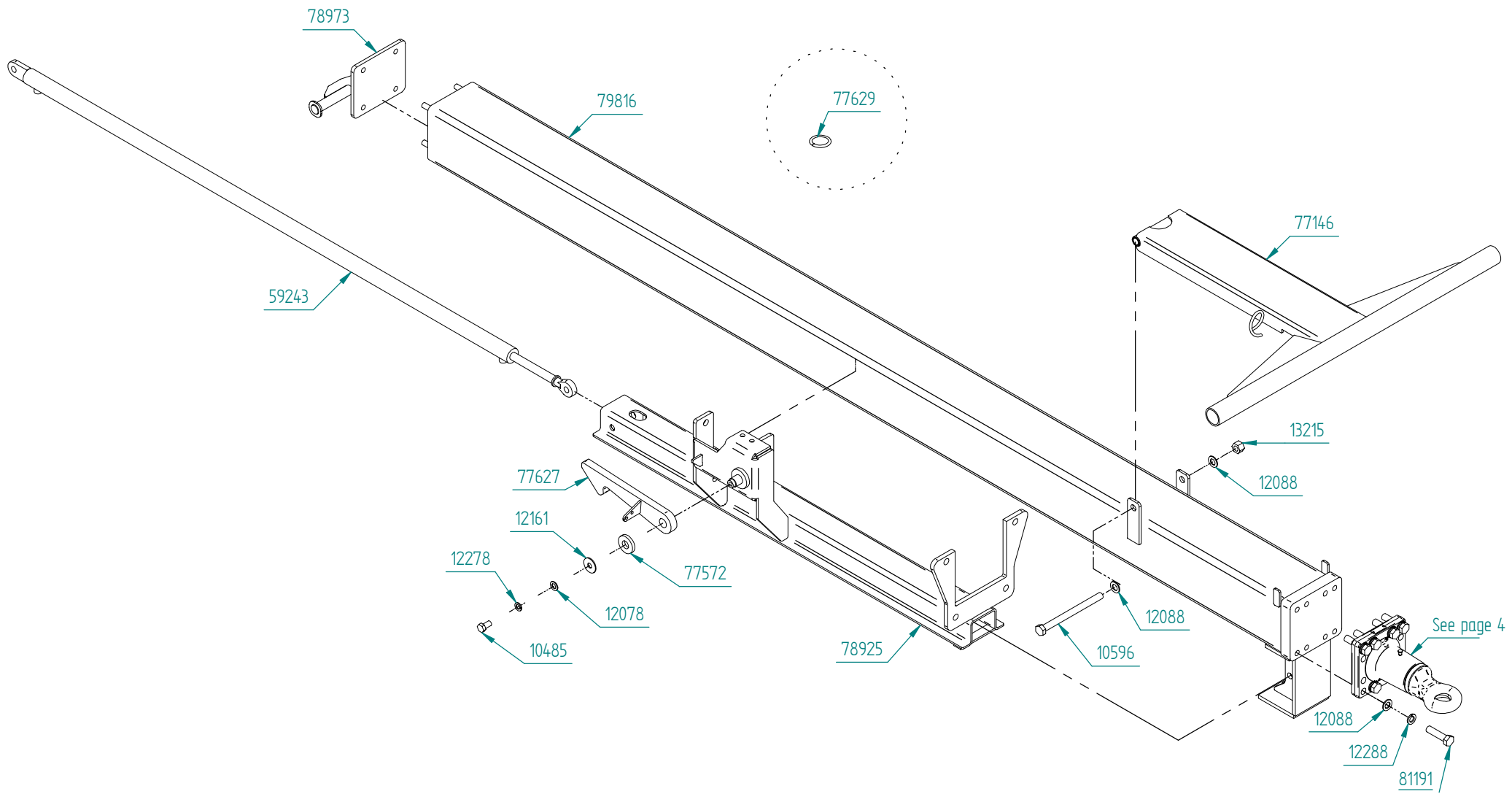

Part Number	Qty.	Title
10485	1	Bolt M16x30, threaded to head
81191	1	Bolt M20x65, set with 8 pc
10596	1	Bolt M20x250
12078	1	Washer M16
12088	10	Washer M20
12161	3	Washer \varnothing 50/17x3
12278	1	Spring washer M16
12288	8	Spring washer M20
13215	1	Lock nut M20
page 5	1	PTO drive shaft, wide angle
page 5	1	PTO drive shaft, standard
59243	1	Cylinder 50x30x1950
page 4	1	Draw bar eye, ball
page 4	1	Draw bar eye, turnable
page 4	1	Draw bar eye, euro
77146	1	Support, wrapper
77572	1	Locking hook, draw bar, washer
77627	1	Locking hook, draw bar
77629	1	Ring for wire \varnothing 50x8
78925	1	Cylinder bracket, draw bar cylinder
79816	1	Draw bar, standard
78973	1	End plate, draw bar

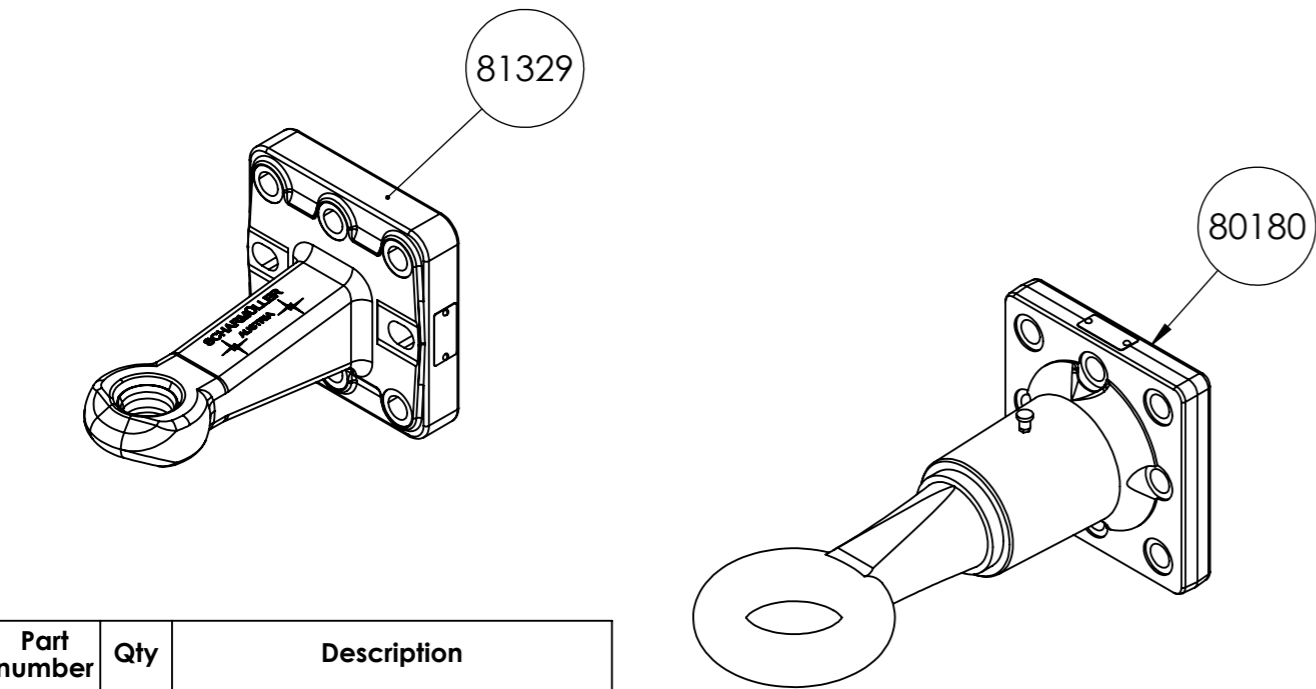
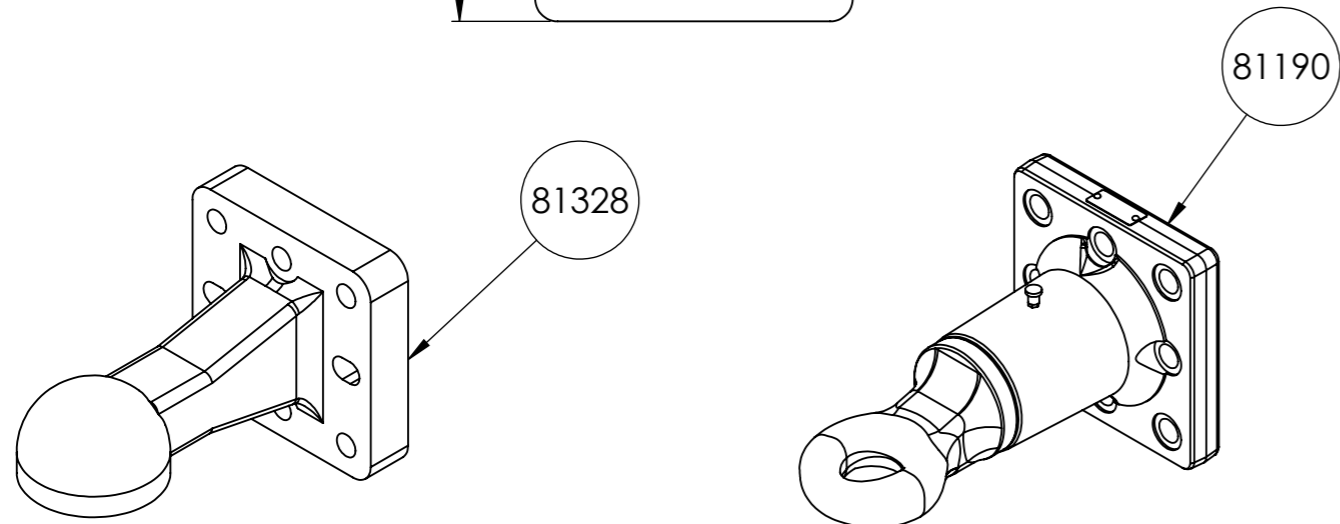
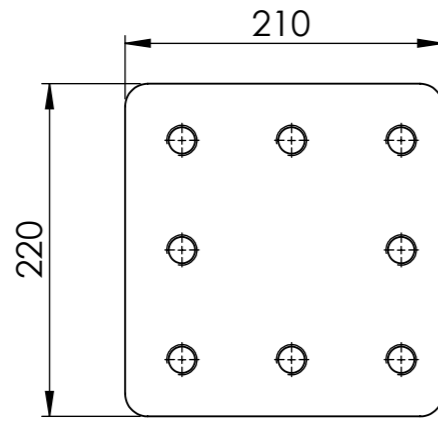

Part number	Qty	Description
81190	1	Draw bar eye, turnable, ø50
81328	1	Drawbar eye, ball
81329	1	Drawbar eye, euro, ø40
80180	1	Drawbar eye, ø76

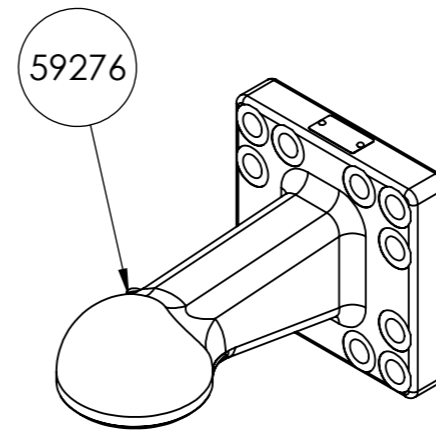
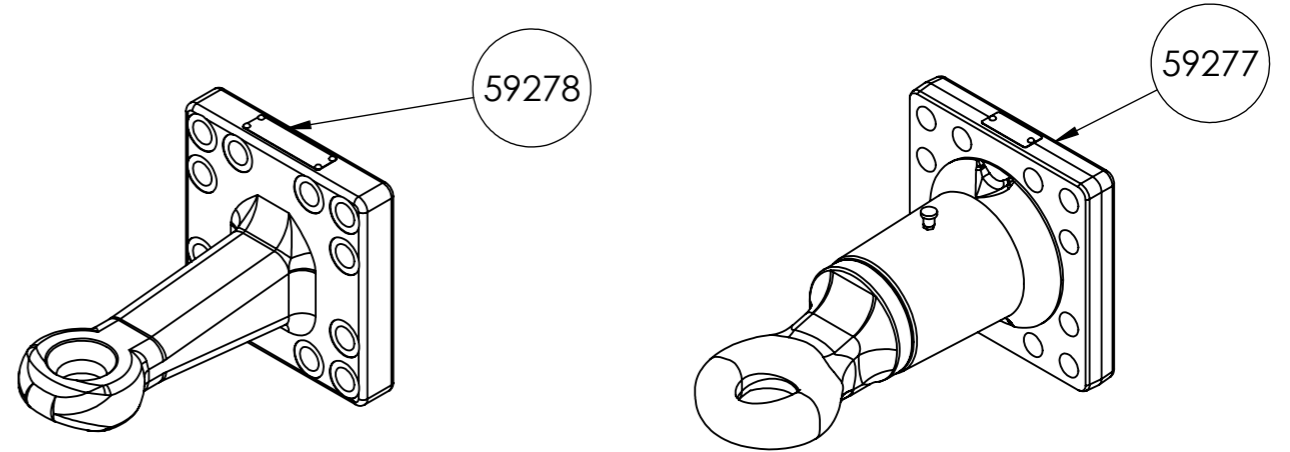
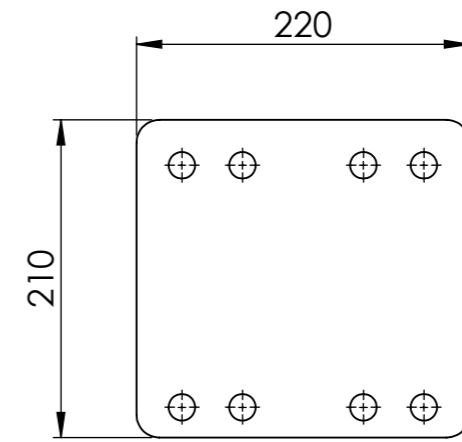

Part number	Qty	Description
59276	1	Draw bar eye, ball
59277	1	Draw bar eye, turnable, ø50
59278	1	Drawbar eye, euro, ø40

Part number	Qty	Description
78624	1	PTO drive shaft, wide angle, 6-spline
59033	1	PTO drive shaft, standard, 6-spline
81172	1	PTO drive shaft, wide angle, 8-spline
80949	1	PTO drive shaft, standard, 8-spline
81086	1	PTO drive shaft, wide angle, 21-spline
81092	1	PTO drive shaft, standard, 21-spline

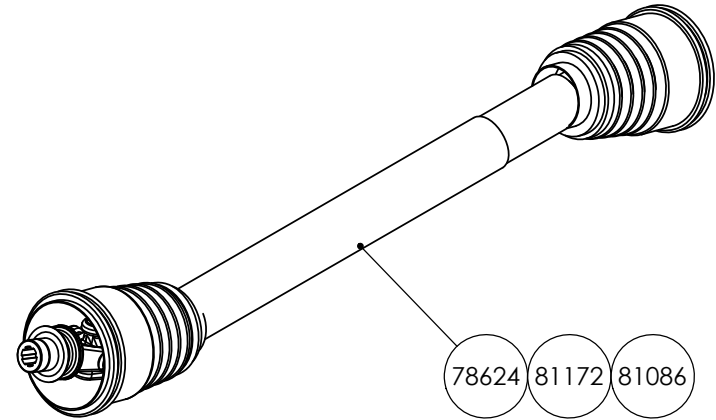
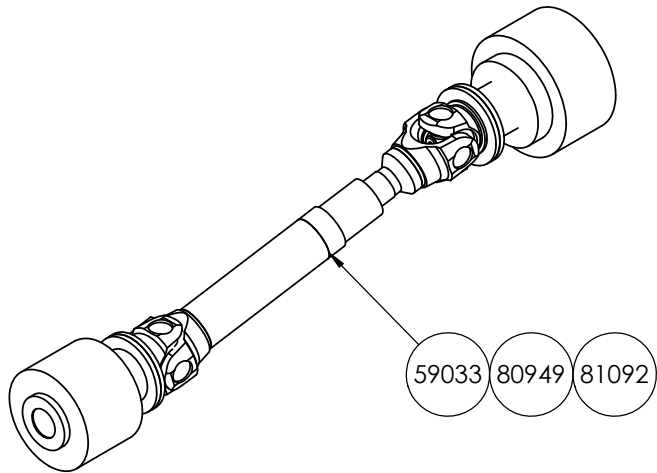

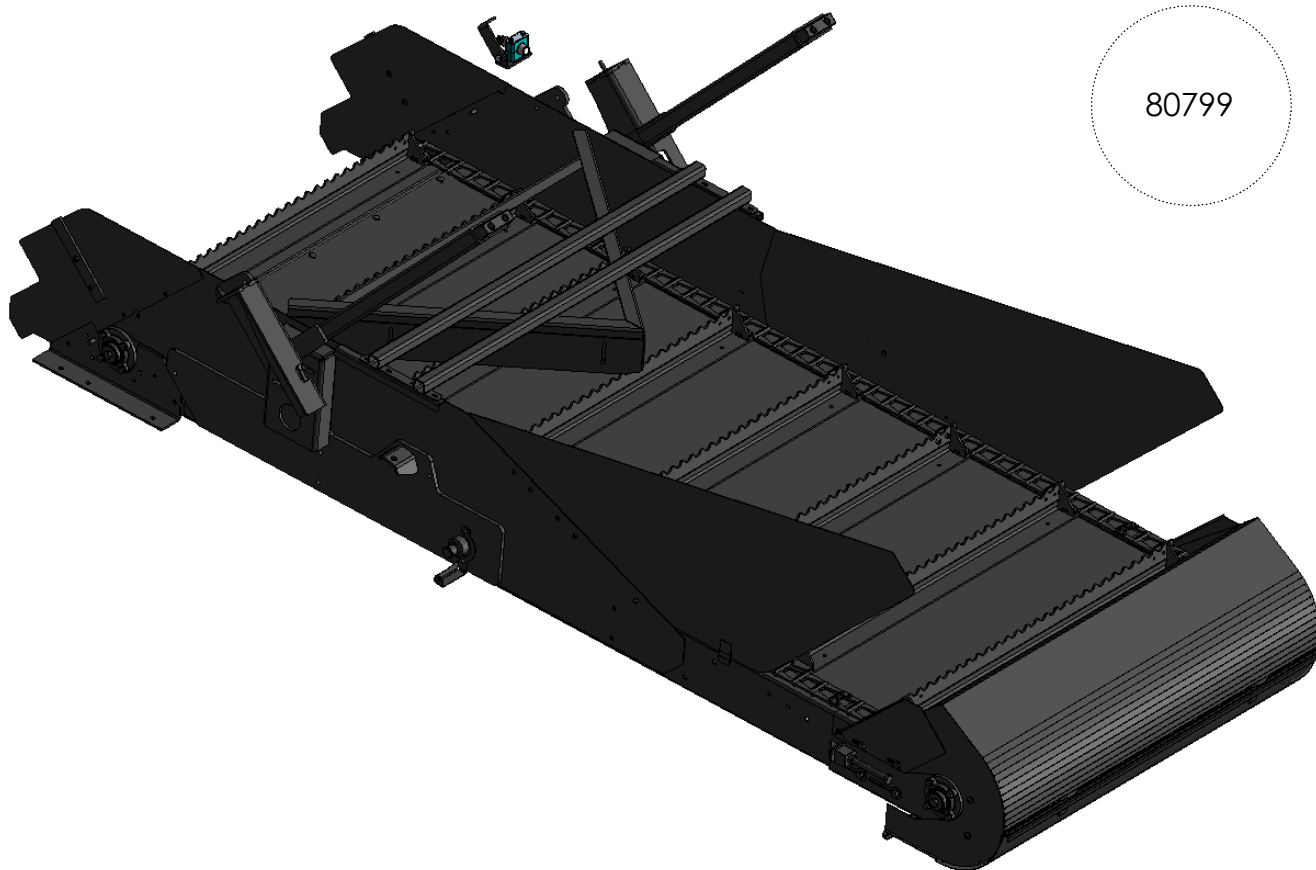

80799

Part number	Qty	Description
10299	1	Bolt M10 x 30 DIN 933 8.8 FZV
10489	4	Bolt M16 x 40 DIN 933 8.8 FZV
12060	2	Washer 10,5 DIN 125A -140HV FZV
12236	2	Spring washer M6
12278	4	Spring washer 16,2 DIN 127 B FZV
13010	1	Nut M10
16520	2	Bolt M6x65, untreated, black
59248	1	Top plate for plastic clamp
59325	2	Plastic clamps 35 mm
77066	1	Hatch, loss funnel
53044	2	Eccentric lock, hake no. 15
77214	1	Middle cover, right
77215	1	Middle cover, left
77240	1	Inner bracket, ultrasound sensor
78058	1	Spill tray, expanding
53029	2	Eccentric lock
78793	2	Nut plate, cylinder bracket
82608	1	Rubber block
10248	2	Bolt M8 x 30 DIN 933
82610	1	F10 support, right
82611	1	F10 support, left
79311	1	Mount for ultrasonic sensor
79374	1	Vibration absorber for US sensor
80195	1	Cable 5-lead
81469	1	Ultrasonic sensor mic + 130 / IU / TC
82293	1	P - sealer strip, hatch elevator

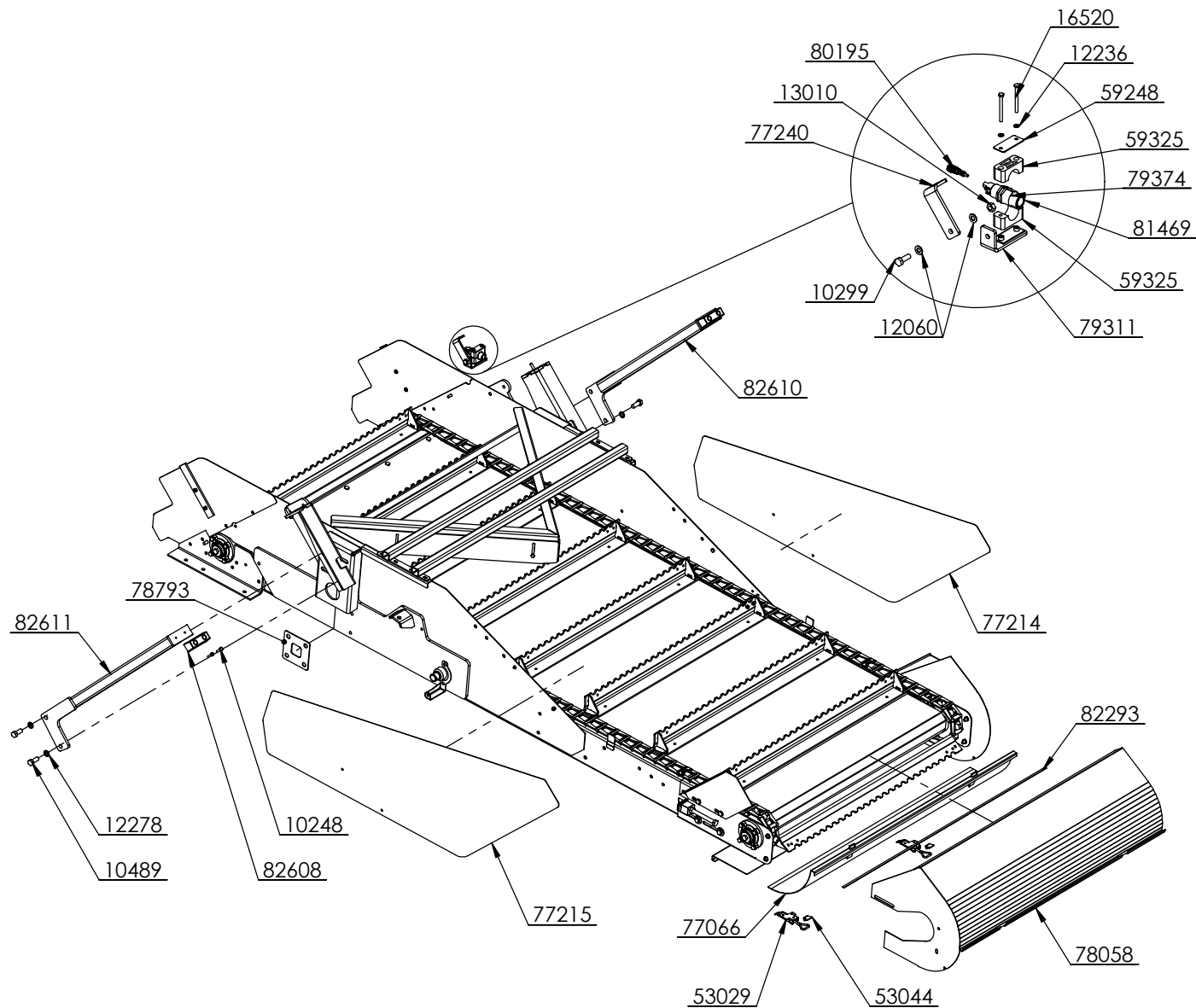

Part number	Qty	Description
12060	2	Washer 10,5 DIN 125A -140HV FZV
16503	2	Bolt M8x20, black
77206	1	Sealing plate, left spill tray
77207	1	Sealing plate, right spill tray
77025	1	Tightener, left side
77026	1	Tightener, right side
77369	1	Winding protection, lower
77598	2	Upper cover
77362	1	Bracket, upper fastener, left
77576	2	Upper cover, reinforcement sealing plate
78728	1	Side cover, left
78513	1	Cylinder bracket, left
77016	1	Shaft, tightening side
77351	2	Adjustment plate, plow
78828	1	Plow
55016	4	Bearing UCFCX08
77382	2	Winding protection bearing
12161	4	Washer 17 x 50 x 3 DIN 9021 FZV
13209	14	Lock nut M8
11447	1	Lense head bolt M12x30
10305	16	Bolt M10x45
15301	3	Bolt M14x20
10297	1	Bolt M10 x 25 DIN 933 8.8 FZV
10246	4	Bolt M8 x 25 DIN 933 8.8 FZV
13612	1	Pan bolt M8x20
13606	4	Pan bolt M10x25
12178	8	Washer 13 x 37 x 3 DIN 9021 FZV
10348	8	Bolt M12 x 30 DIN 933 8.8 FZV
12267	8	Spring washer 12,2 DIN 127 B FZV
13013	2	Nut M16 DIN 934 Cl.8 FZV
15215	2	Bolt M16 x 180 DIN 933 8.8 FZV
15505	2	Circlip A30x1,5
78867	17	Carrier
50015	164	Chain link Kohlswa Ewart 78
15905	4	Button head screw w/flange M8x20
82088	1	Lower tower with bracket, right, platform
16529	1	Bolt M10 x 40 DIN 933 Black
82089	1	Lower tower with bracket, left, platform
79844	2	Chain link Kohlswa Ewart 78, modified
79845	2	Chain link plate
79650	1	Bracket, safety cover, right
79656	1	Bracket, safety cover, left
52507	2	Key 12x8x50 DIN 6885 A
59081	2	Sprocket

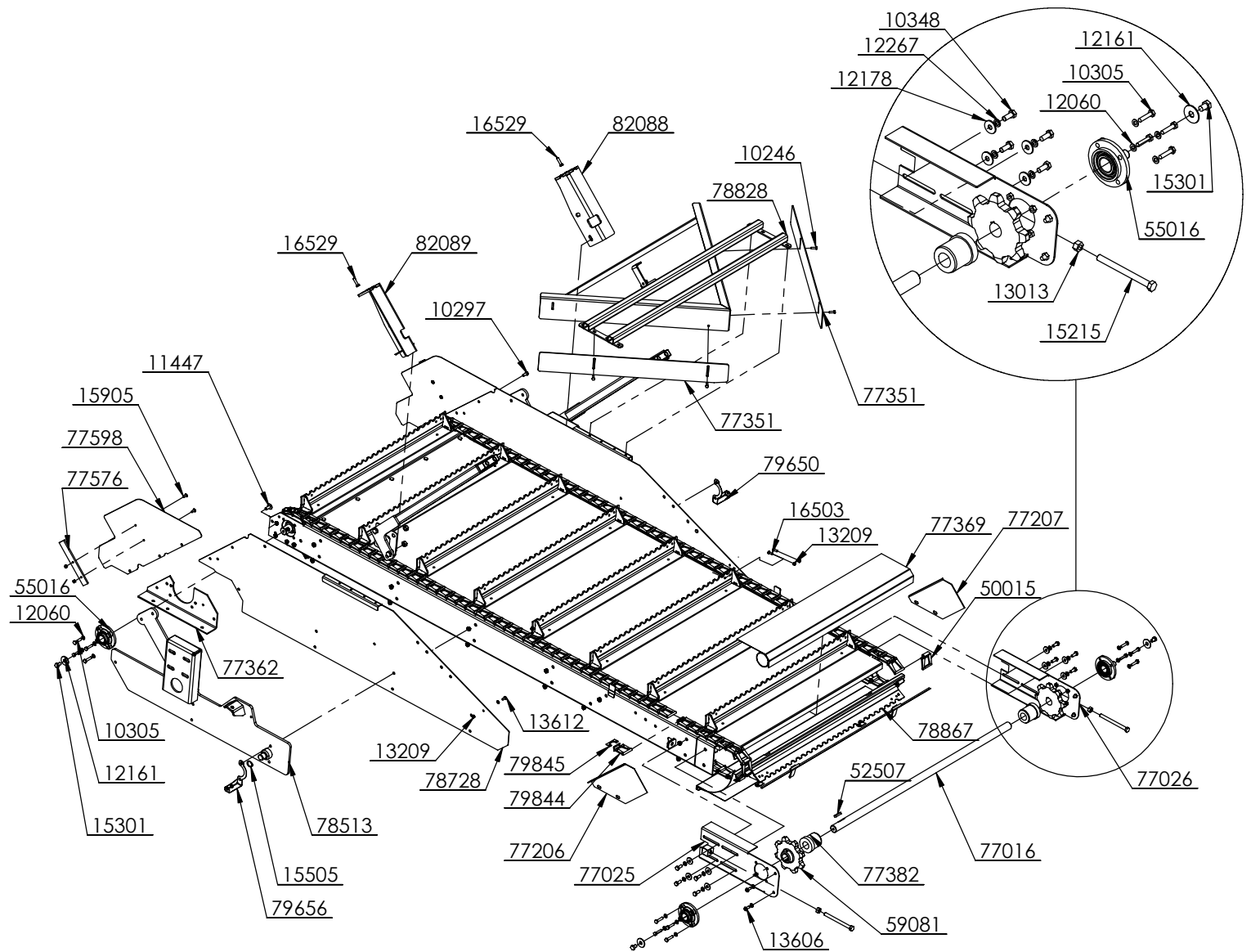

Part number	Qty	Description
77024	1	Frame, elevator
77110	1	Winding protection
77598	2	Upper cover
77363	1	Bracket, upper fastener, right
77576	2	Upper cover, reinforcement sealing plate
78727	1	Side wall, right
78514	1	Cylinder bracket, right
78866	1	Bracket, elevator gear
78869	1	Counting wheel, elevator
59038	1	Gear RT 90
59056	1	Motor OR160C
10350	2	Bolt M12x35
12067	2	Washer 13 DIN 125A -140HV FZV
35010	2	Fitting 1/2"-1/2"
53306	2	Gasket 1/2"
77506	2	Plastic guide rail for belt
77154	1	Visaform plate, lower
55016	4	Bearing UCFCX08
59081	2	Sprocket
12161	4	Washer 17 x 50 x 3 DIN 9021 FZV
12060	20	Washer 10,5 DIN 125A -140HV FZV
11123	5	Bolt M8x120 DIN 603 A4 80
12047	10	Washer 8,4 DIN 125A -140HV FZV
13209	14	Lock nut M8
11101	5	Bolt M8x40 DIN 603 A4 80
11447	1	Lense head bolt M12x30
10305	16	Bolt M10x45
12260	4	Spring washer 10,2 DIN 127 B FZV
10299	4	Bolt M10 x 30 DIN 933 8.8 FZV
11116	4	Bolt M8x25 DIN 603 A4 80
50805	2	Key 10x8x50
52507	1	Key 12x8x50 DIN 6885 A
10402	1	Bolt M14x50
15505	2	Circlip A30x1,5
57708	2	Shims
79650	1	Bracket, safety cover, right
82278	1	Distance sleeve
77015	1	Driveshaft, elevator
11303	2	Set screw M12x12

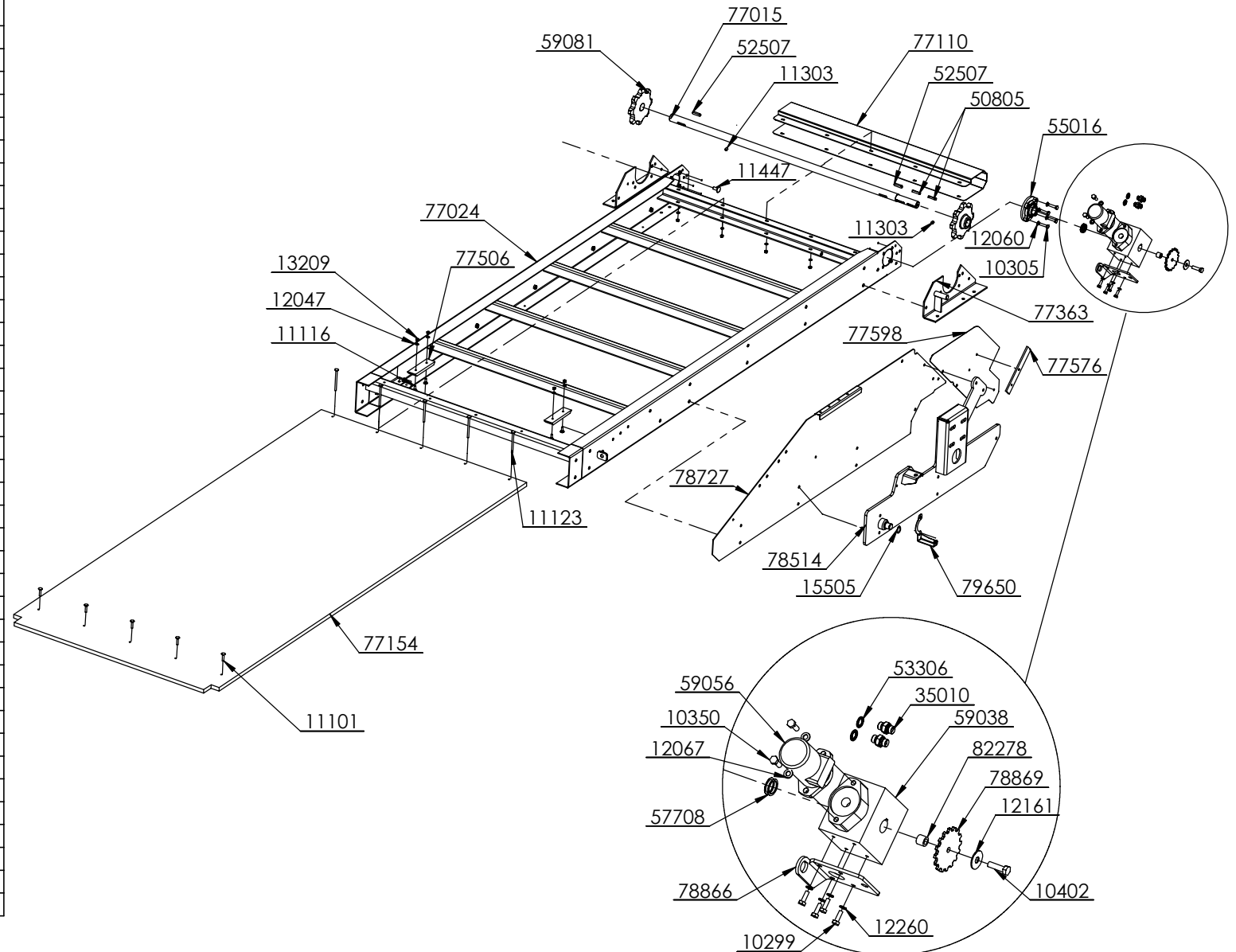

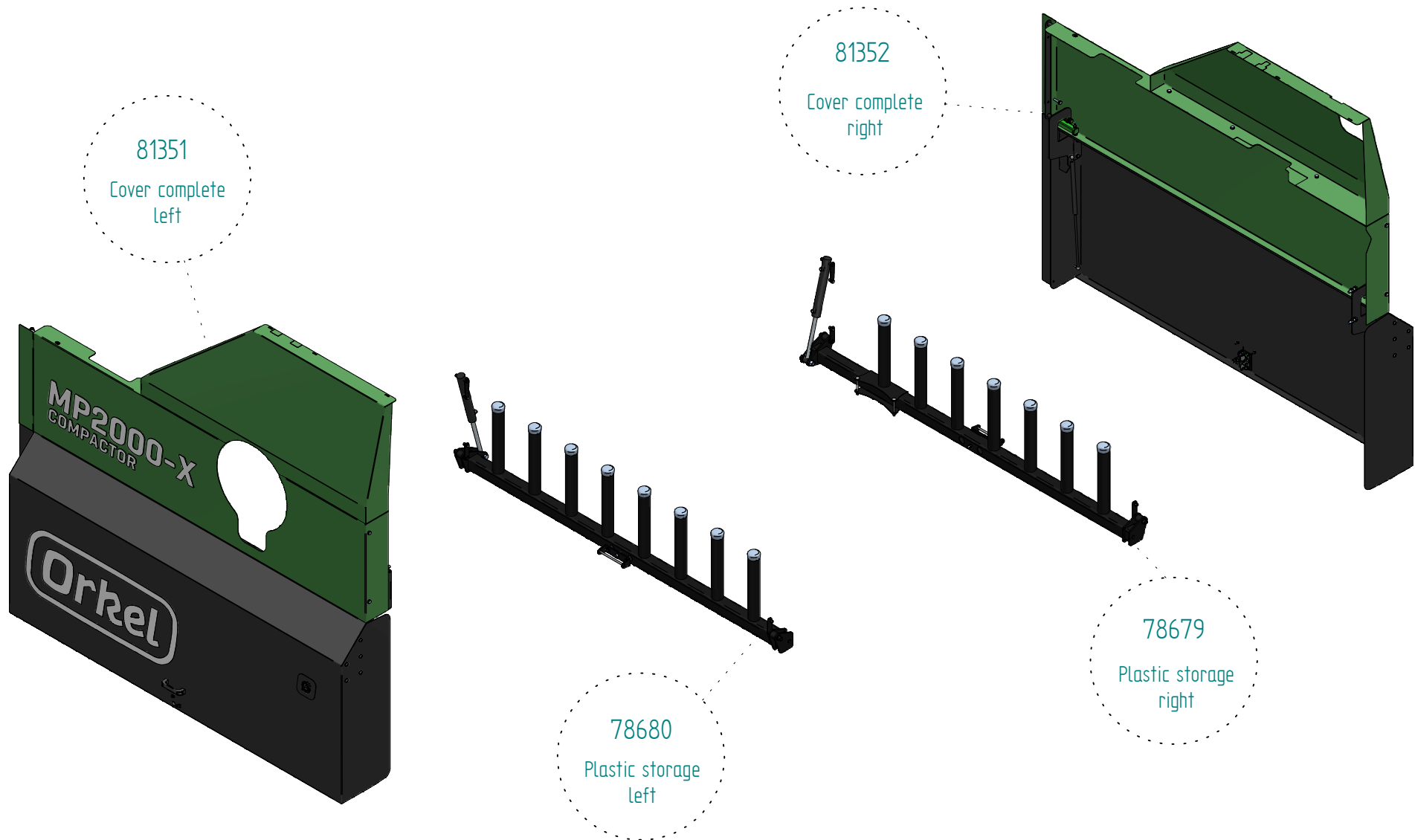

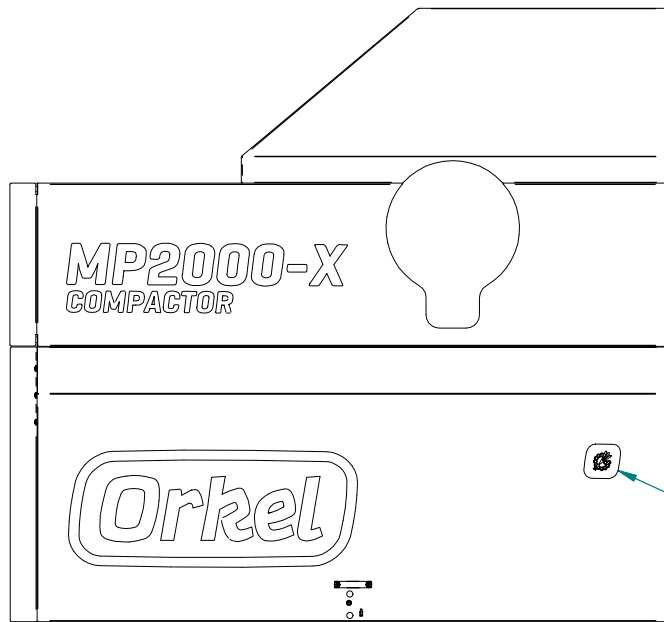

16303

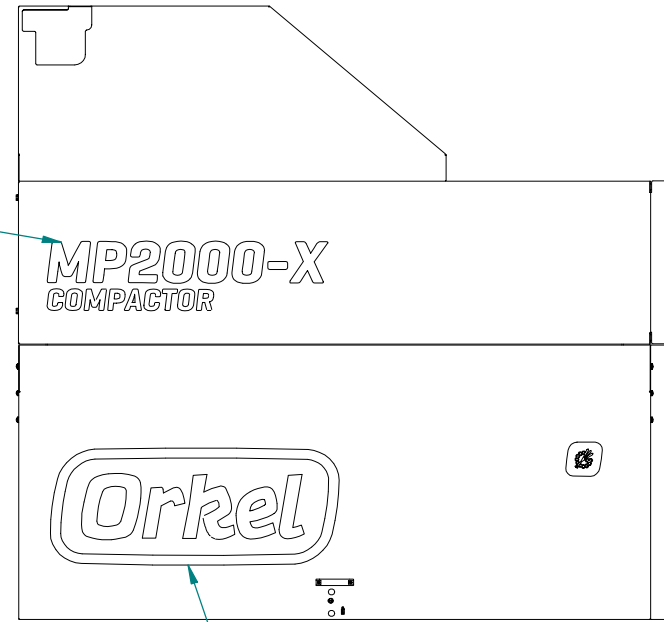

16243

16226

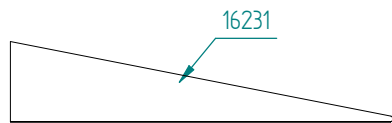

16231



Stickers

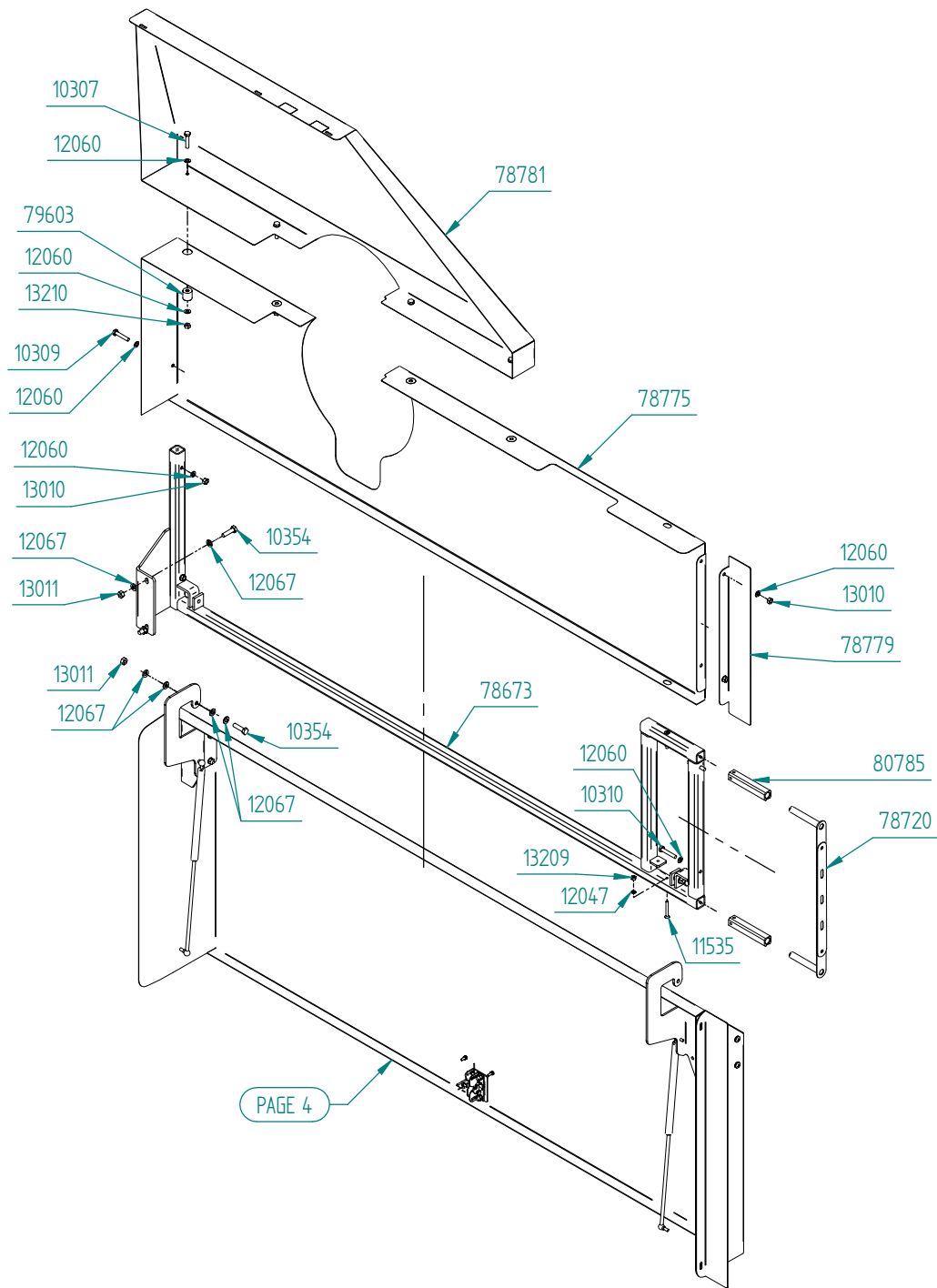
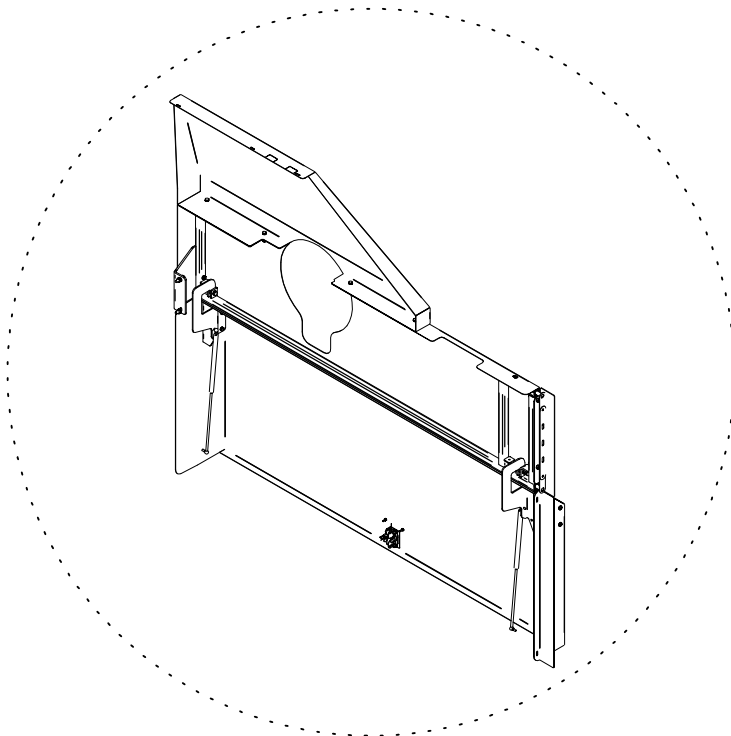

PAGE 4

Cover
Left

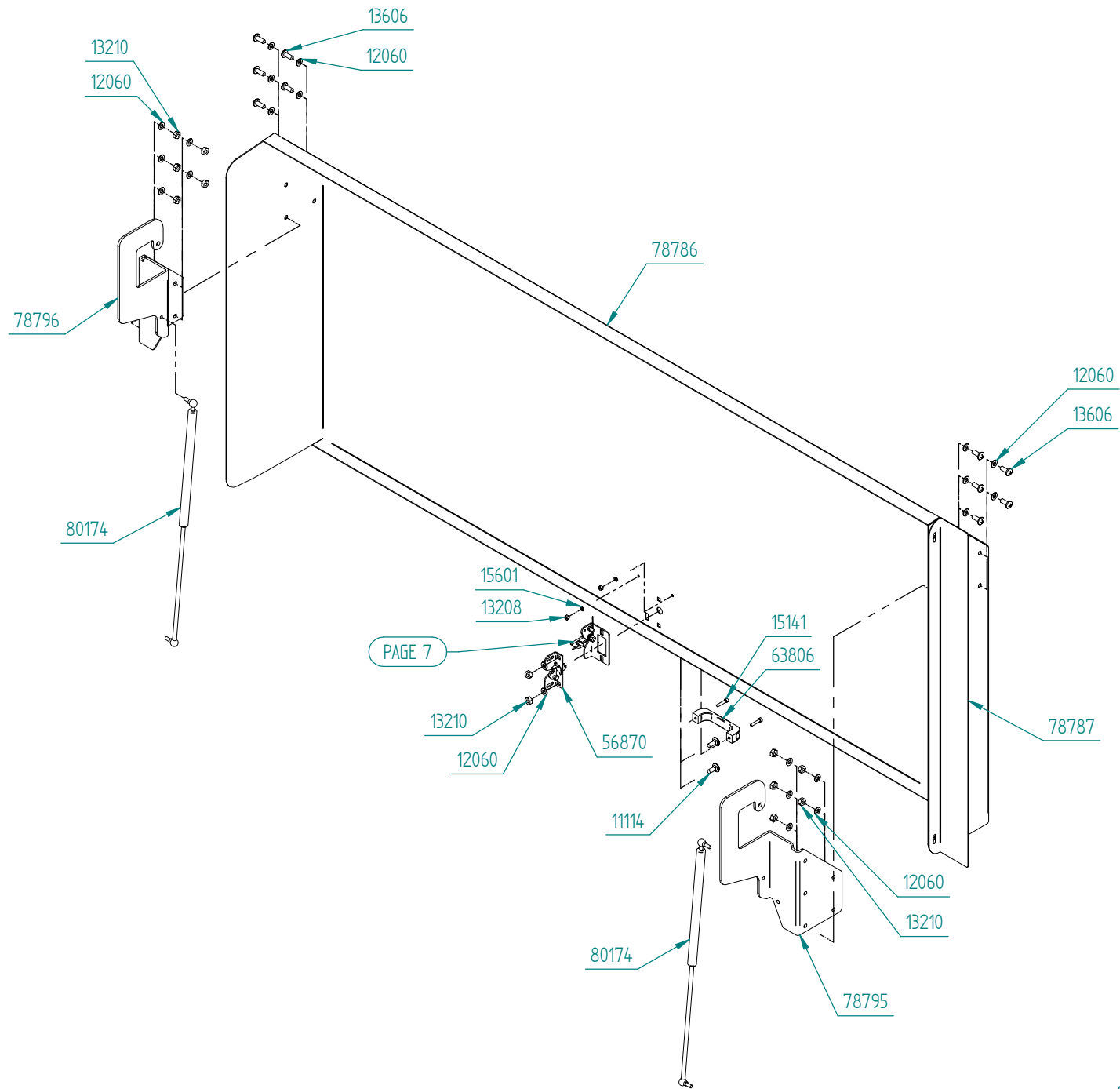

PAGE 7

Cover
Left

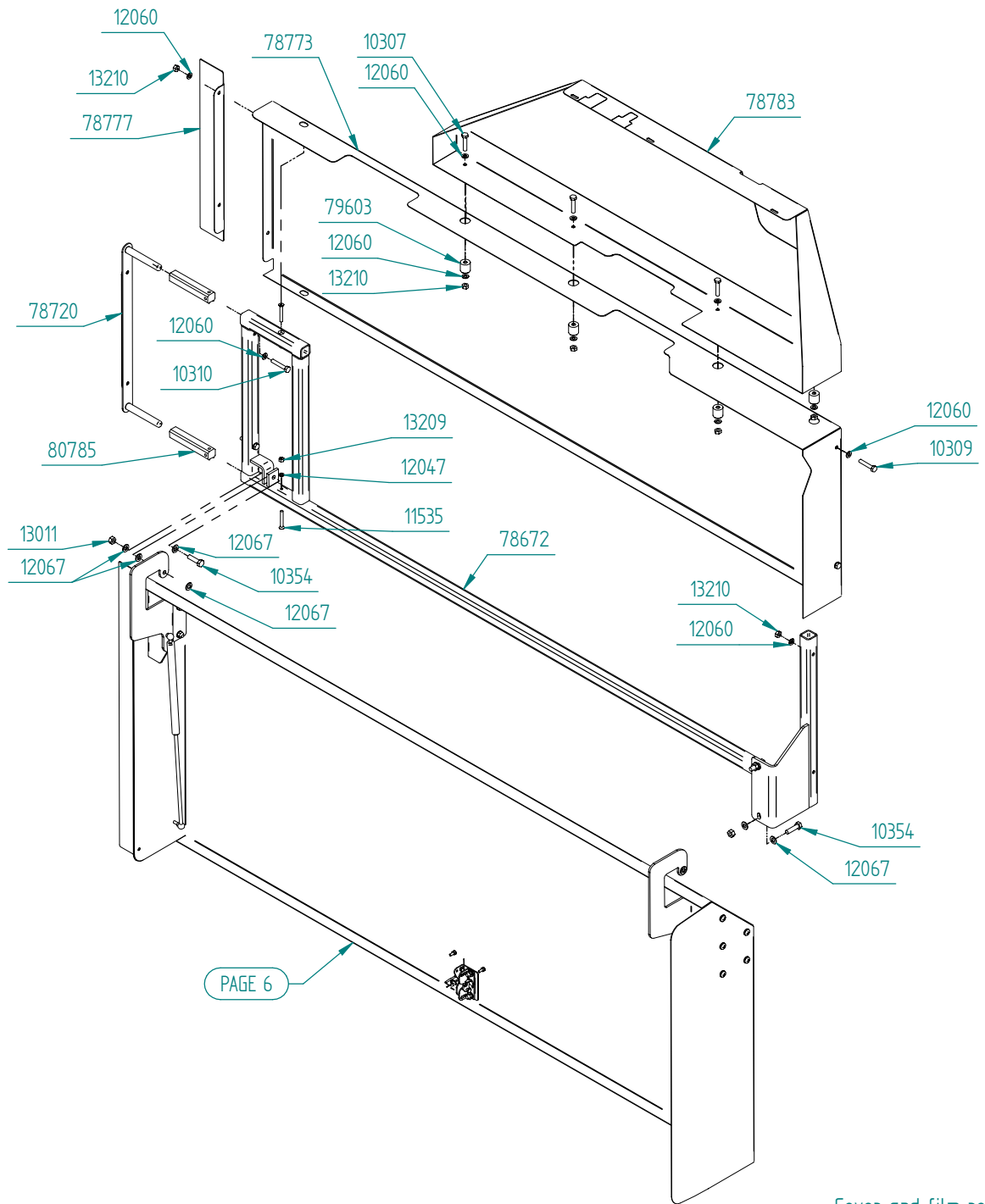
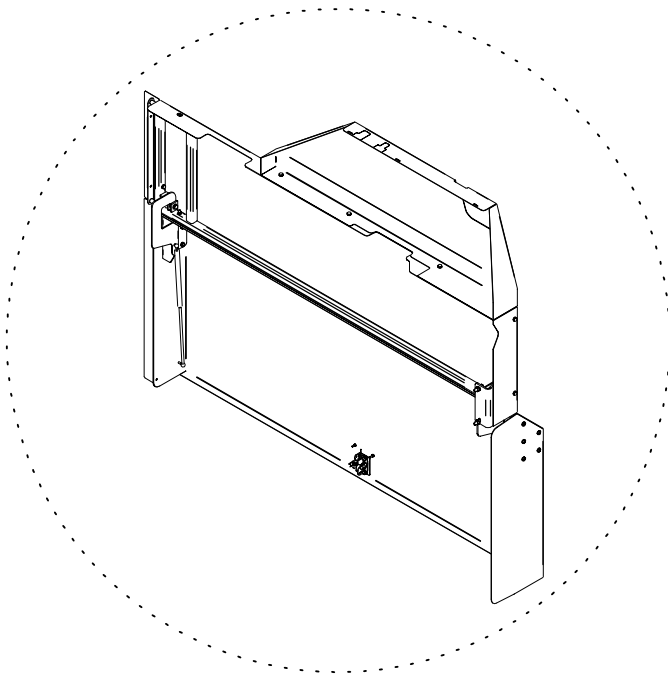

PAGE 6

Cover
right

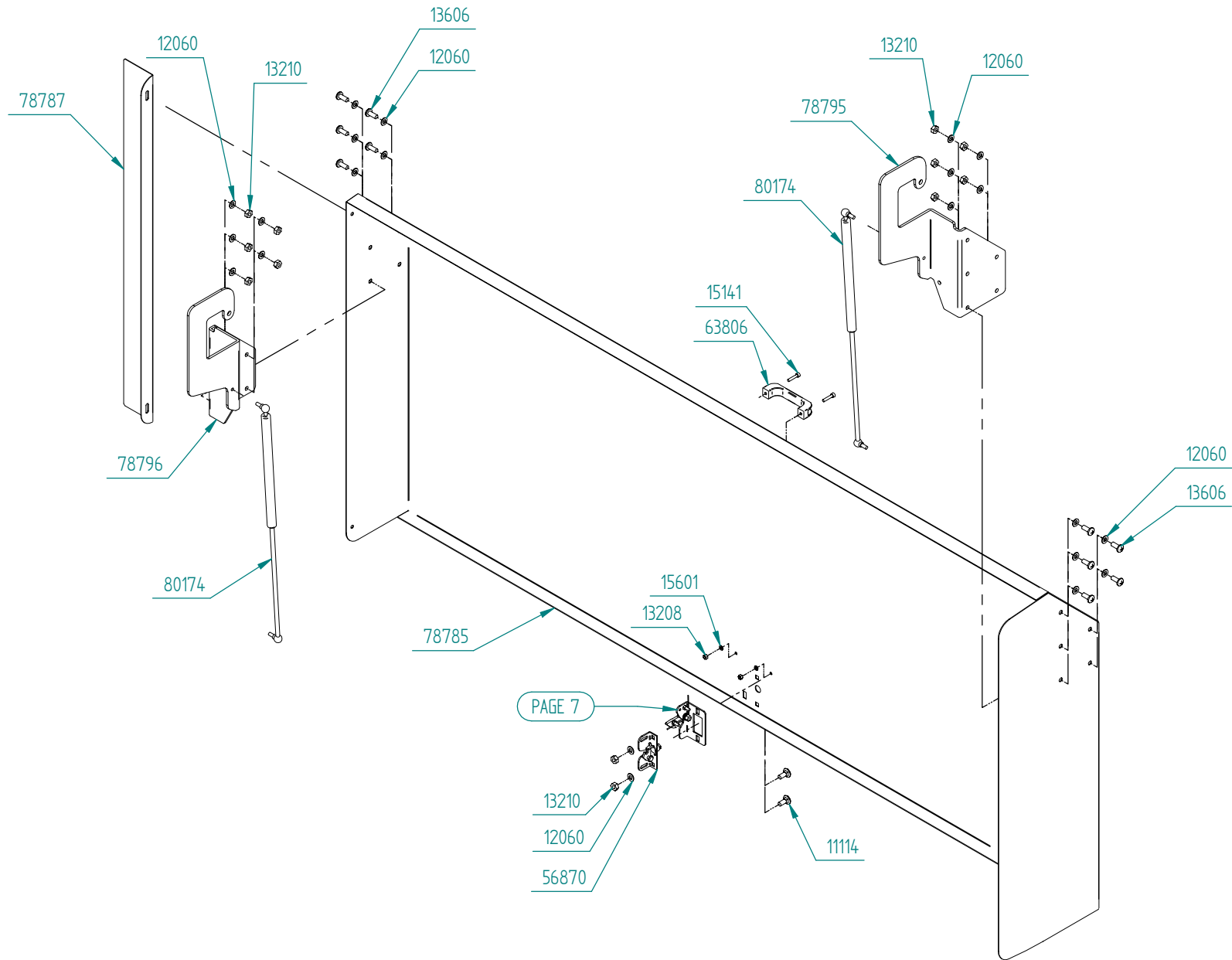

PAGE 7

Cover
right

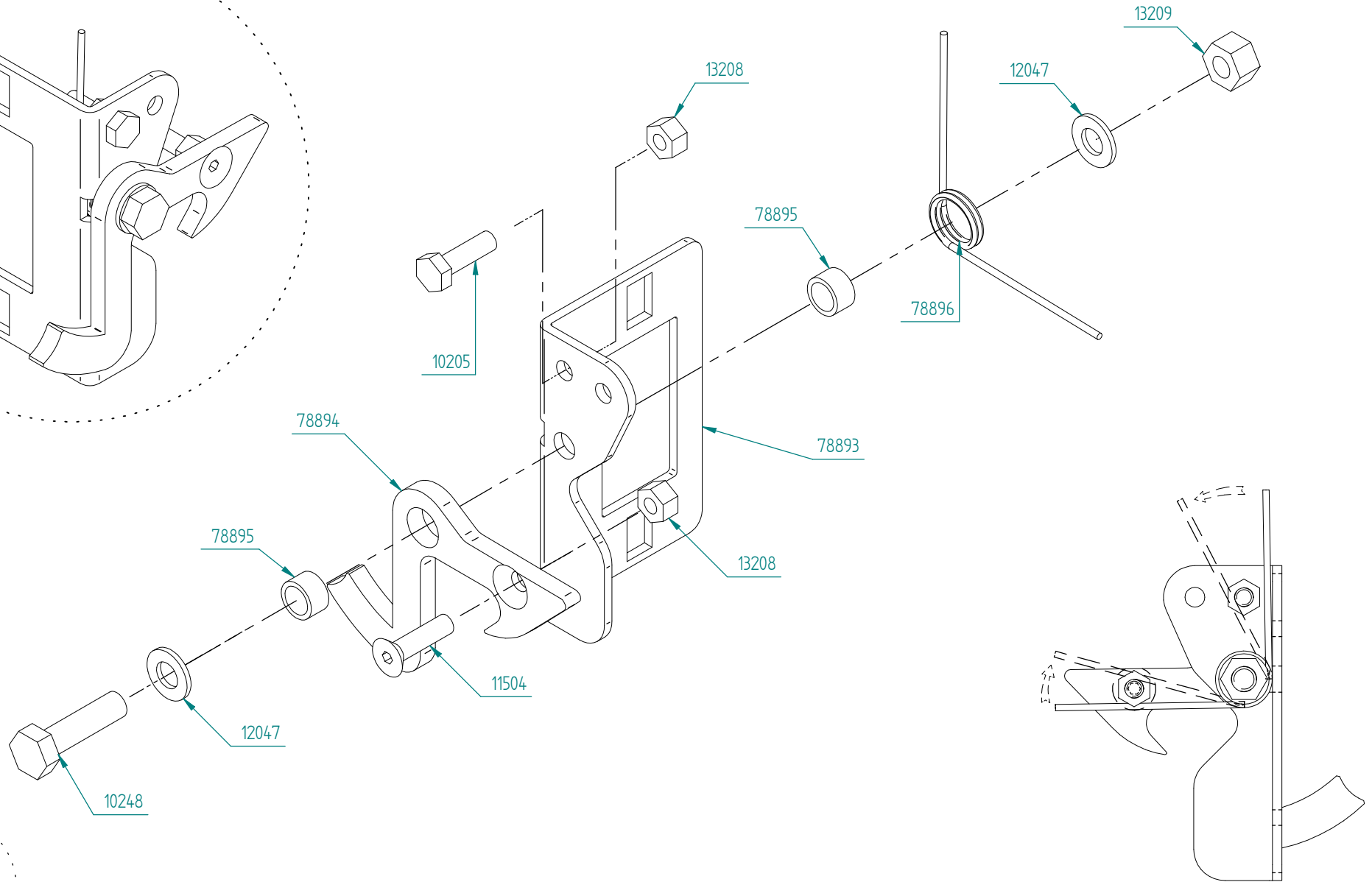
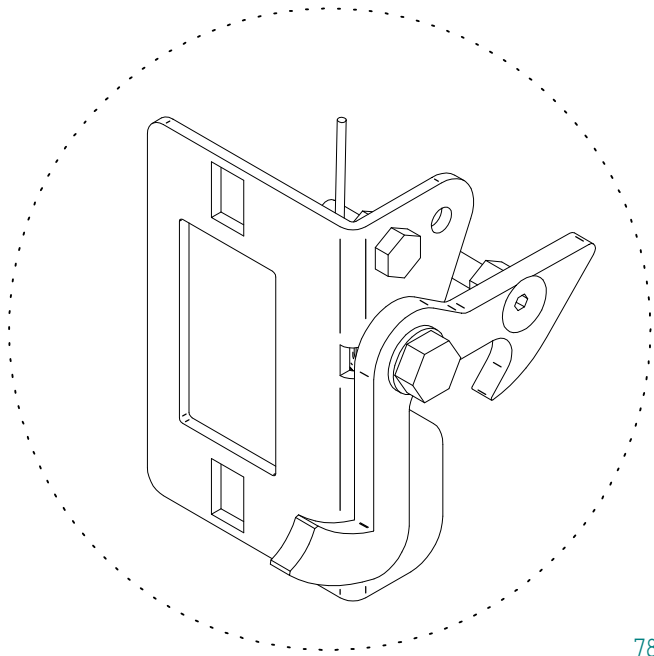

Cover
left and
right

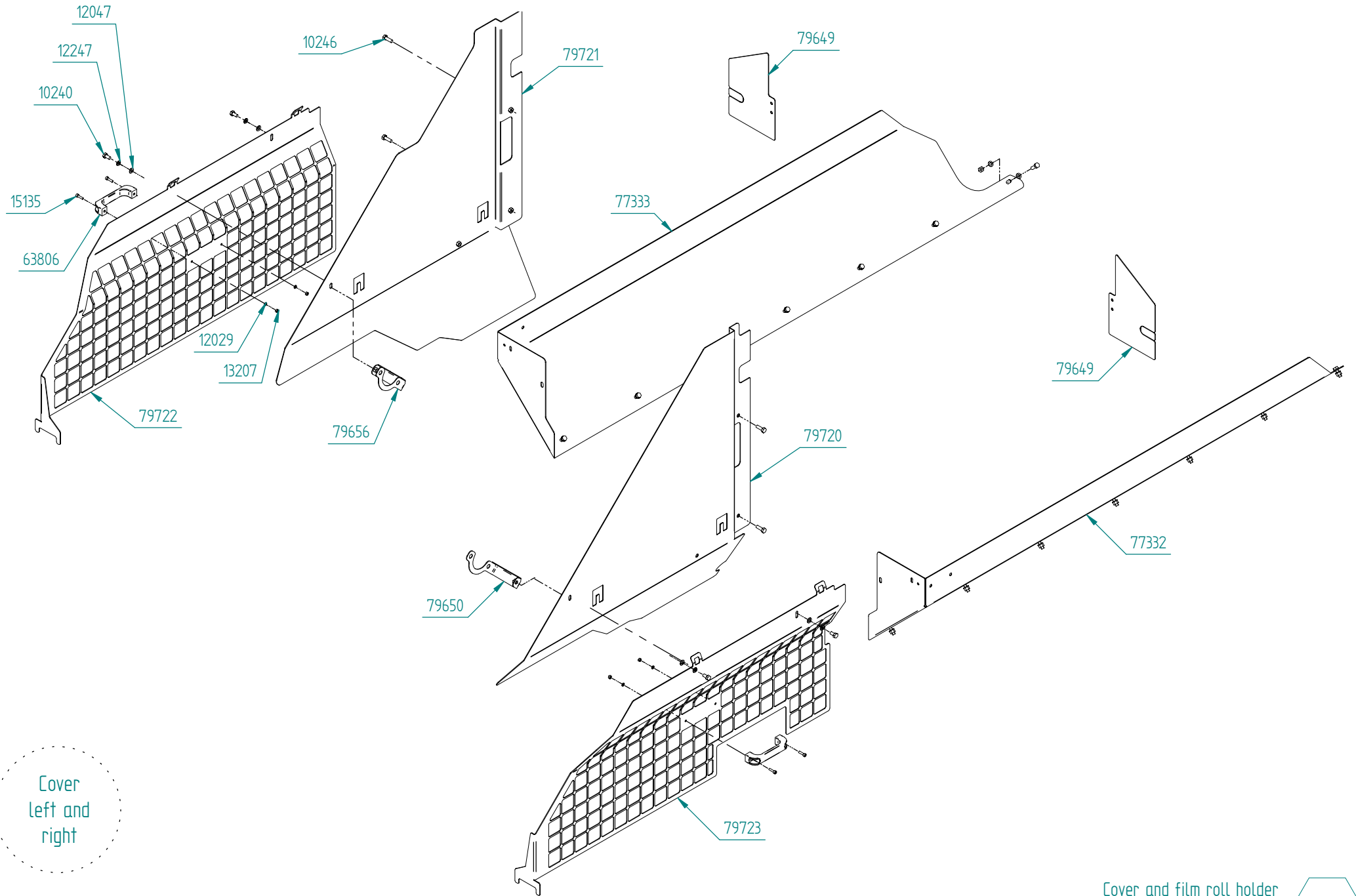

Cover
 left and
 right

Part number	Qty	Description
10201	4	Bolt M6x16, threaded to head
11446	8	M8x20
12159	16	Washer ø18/6,4
12183	11	Washer 9x35x2mm
13031	2	M8 blind nut
13208	12	Lock nut M6
15138	8	M6x20 cylinderhead, galv.
63806	4	Handle
82185	1	Safetycover left
82186	1	Safety cover, right
82187	1	Hatch on safetycover for ball valve
82188	1	Sideflap for safetycover, lower
82189	1	Sideflap for safetycover, upper

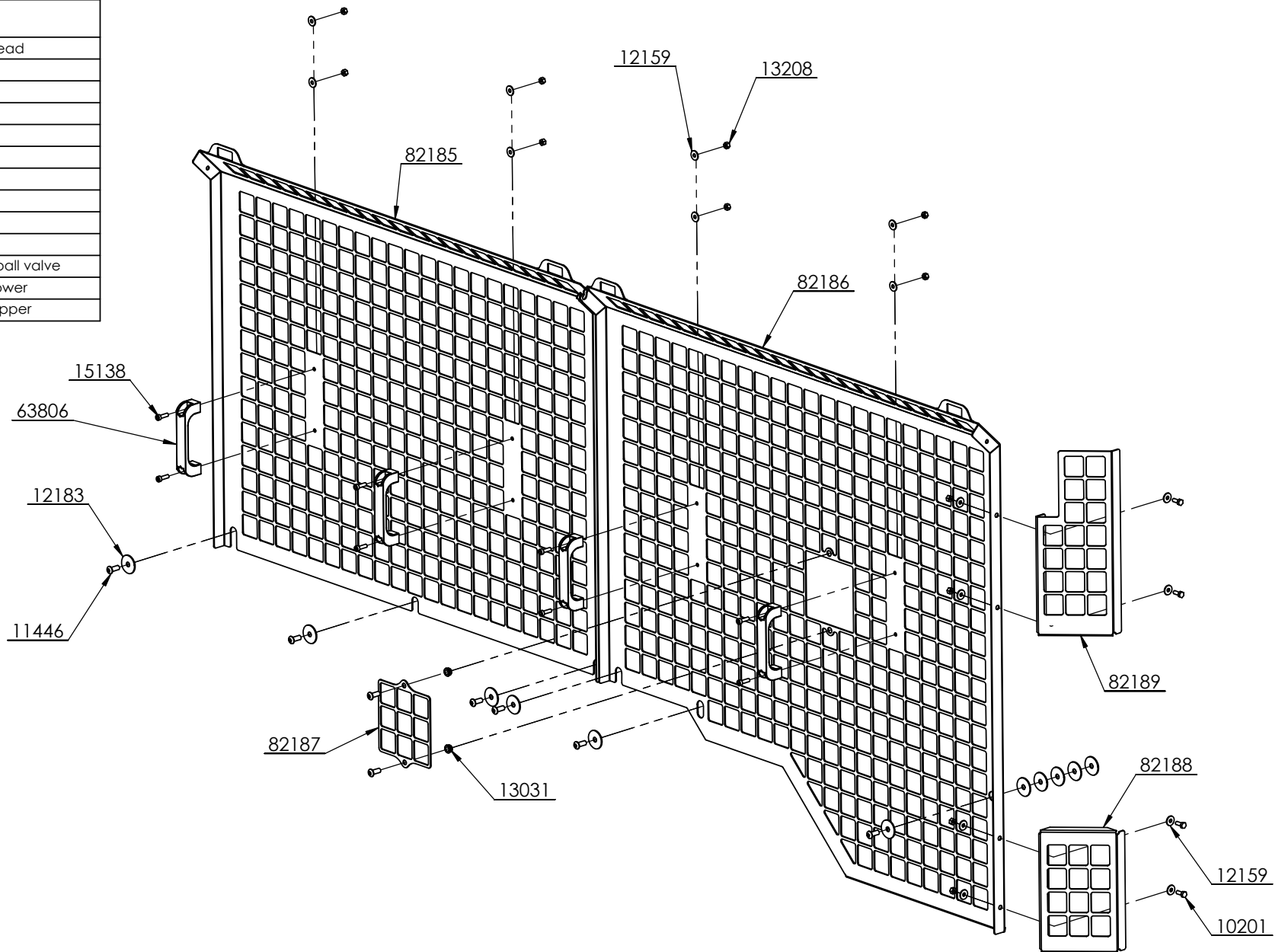

Chain cover
left side

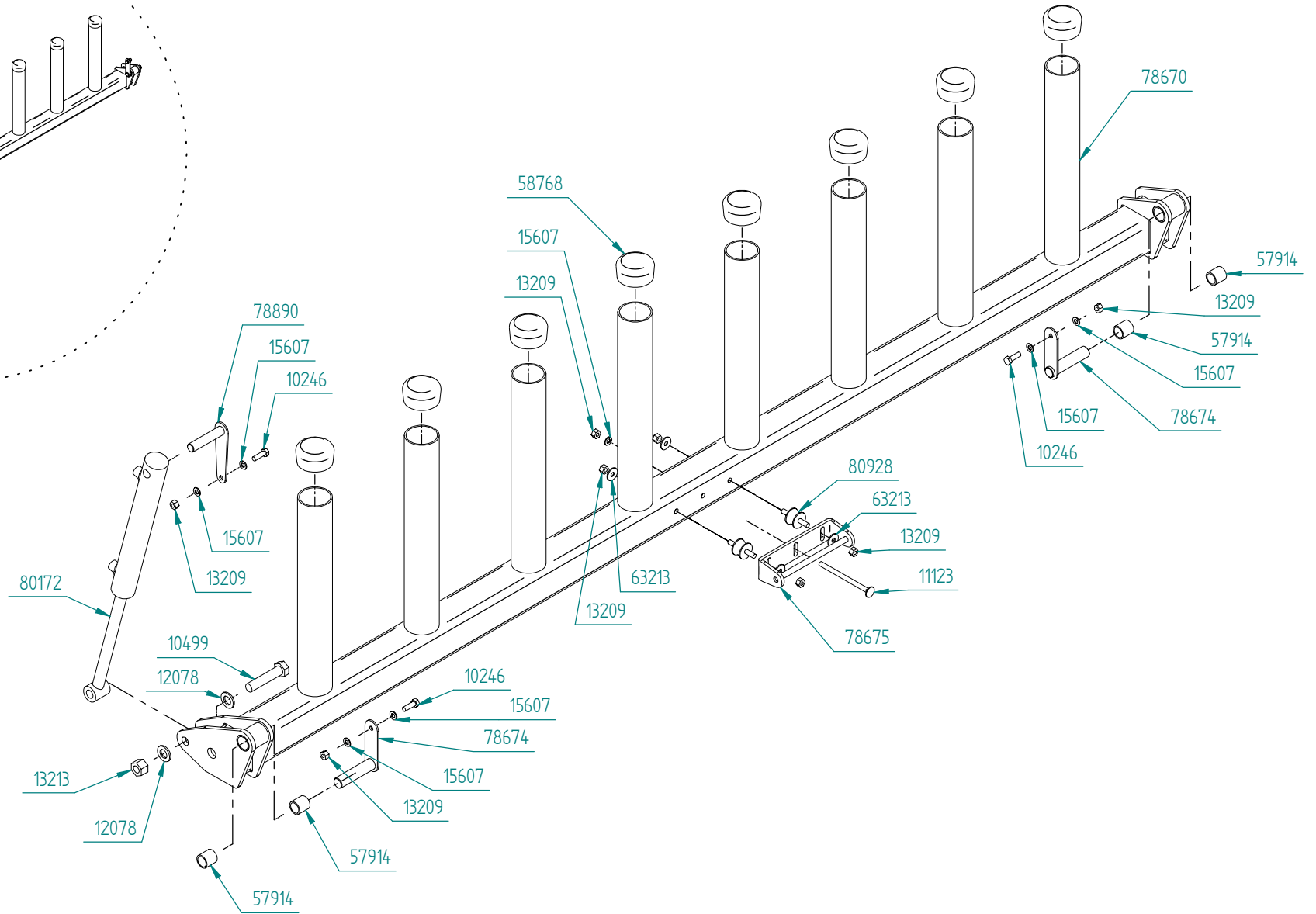
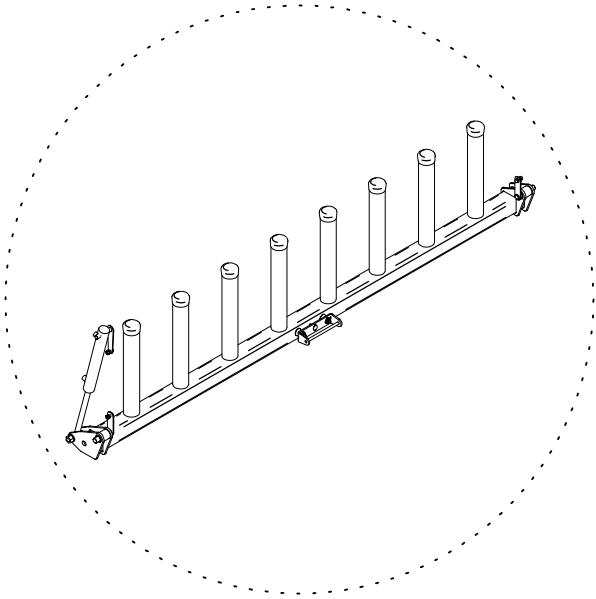

Film roll holder
left

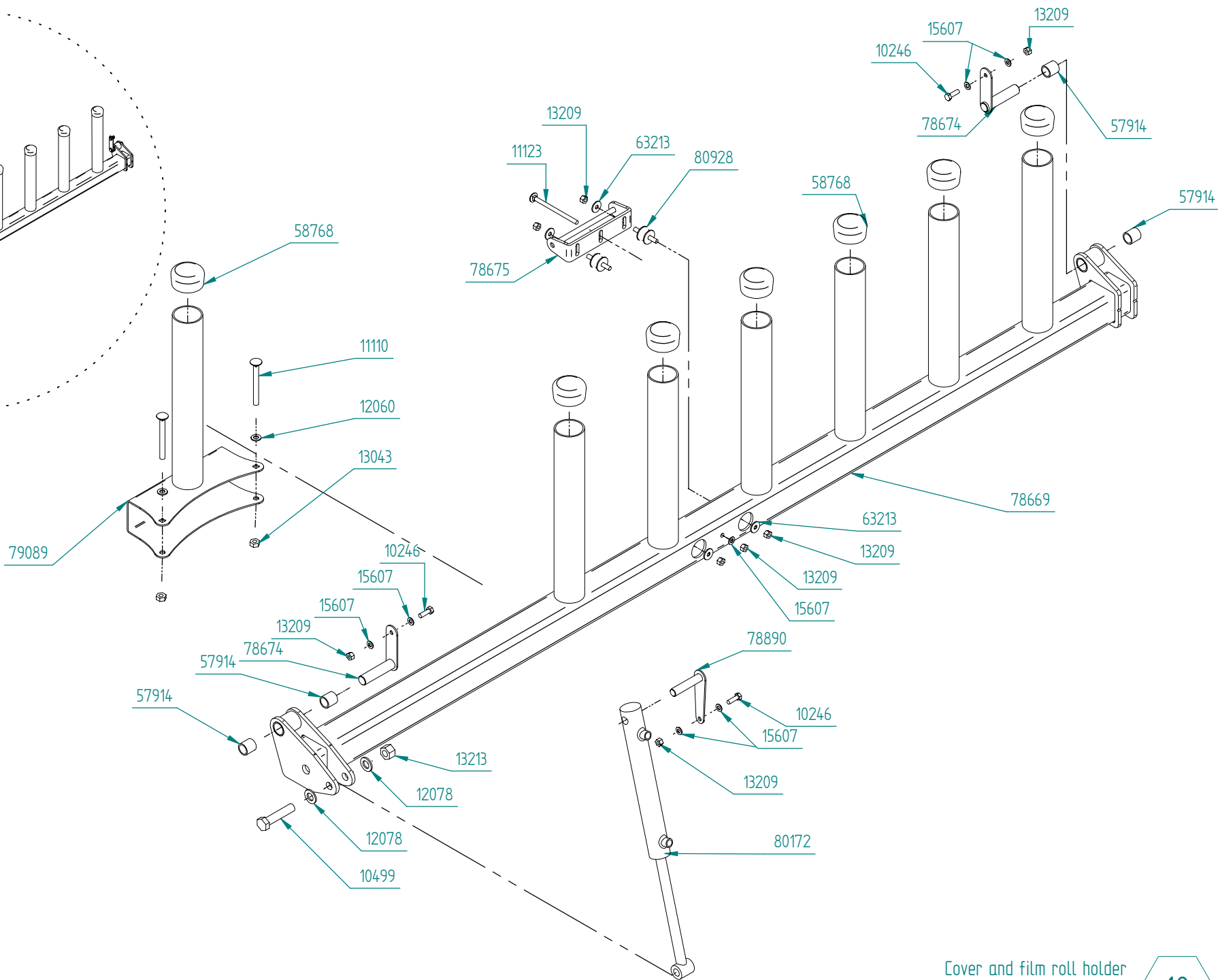
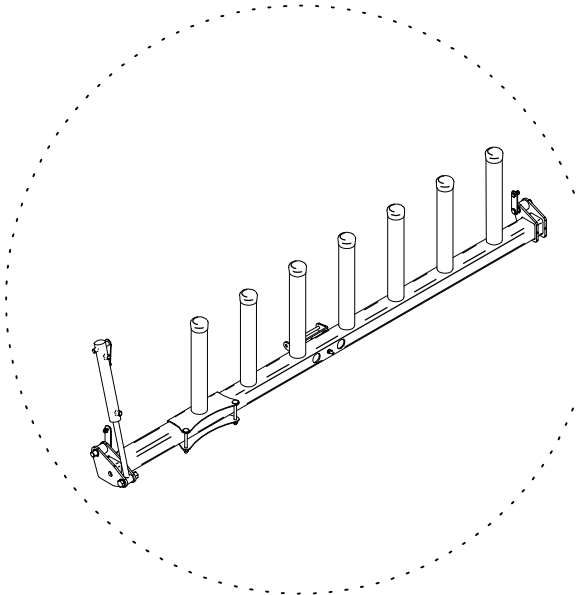

Film roll holder right

Part Number	Qty.	Title
10205	2	Bolt M6x20, threaded to head
10211	3	Bolt M6x35
10240	4	Bolt M8x16
10244	4	Bolt M8x20
10246	24	Bolt M8x25
10248	2	Bolt M8x30
10307	8	Bolt M10x50
10309	4	Bolt M10x55
10310	4	Bolt M10x60
10354	8	Bolt M12x45
10499	2	Bolt M16x75
11110	2	Lockinghead bolt M10x100
11114	4	Locking head bolt M10x25
11123	2	Lock head bolt M8x120
11504	2	Countersunk bolt M6x20
11535	4	Countersunk bolt M8x60
12029	12	Washer M5
12036	9	Washer M6
12047	44	Washer M8
12060	78	Washer M10
12067	24	Washer M12
12078	4	Washer M16
12247	4	Spring washer M8

Part Number	Qty.	Title
13010	4	Nut M10
13011	8	Nut M12
13043	2	Lock nut M10
13207	12	Lock nut M5
13208	15	Lock nut M6
13209	36	Lock nut M8
13210	36	Lock nut M10
13213	2	Lock nut M16
13606	20	Pan bolt M10x25
15135	12	Bolt M5x20, cylinderhead
15141	4	Bolt M6x30, cylinderhead
15601	4	Washer M6, rust free
15607	14	Washer M8, rust free
16226	2	Sticker, Orkel
16231	2	Sticker, green
16243	2	Sticker, Gjøannes
16303	2	-
56870	2	Lock Camlock 2812L
57914	8	Plain bearing
58768	15	Plastic cap ø60
63213	8	Washer ø24/8,4x2
63806	8	Handle
77332	1	Spillage cover, right

Part Number	Qty.	Title
77333	1	Spillage cover, left
78669	1	Film roller storage, right
78670	1	Film roller storage, left
78672	1	Frame Top Cover Right
78673	1	Frame Top Cover Left
78674	4	Shaft Plastic Magazine
78675	2	Counterpart Latch
78720	2	Flexible mount, top cover
78773	1	Top cover, right
78775	1	Top cover, left
78777	1	Extension Top Cover Right
78779	1	Extension Top Cover Left
78781	1	Cover, film system, left
78783	1	Cover, film system, right
78785	1	Cover, film roller storage, right
78786	1	Cover, film roller storage, left
78787	2	Cover extension hatch L/R
78795	2	Hinge, cover, left
78796	2	Hinge, cover, right
78815	1	Frame, chain cover
78846	2	Mounting plate
78847	1	Chain guard mesh
78890	2	Cylinder bolt

Part Number	Qty.	Title
78893	2	Base plate, lock
78894	2	Hook, lock
78895	4	Spacer, safety lock
78896	2	Safety lock, Torsion Spring
79004	1	Bracket
79006	1	Bracket
79008	1	Chain guard mesh
79089	1	Removable plastic film holder
79603	8	Bushing, film system cover
79649	2	Extension Spil Tray
79650	1	Bracket, safety cover, right
79656	1	Bracket, safety cover, left
79720	1	Right cover, below elevator
79721	1	Cover, below elevator, left
79722	1	Safety guard, left
79723	1	Safety guard, right
80172	2	Hydraulic cylinder
80174	4	Gas strut Bansbach
80785	4	Slider, top cover
80907	2	Rubber mount
80928	4	Rubber mount

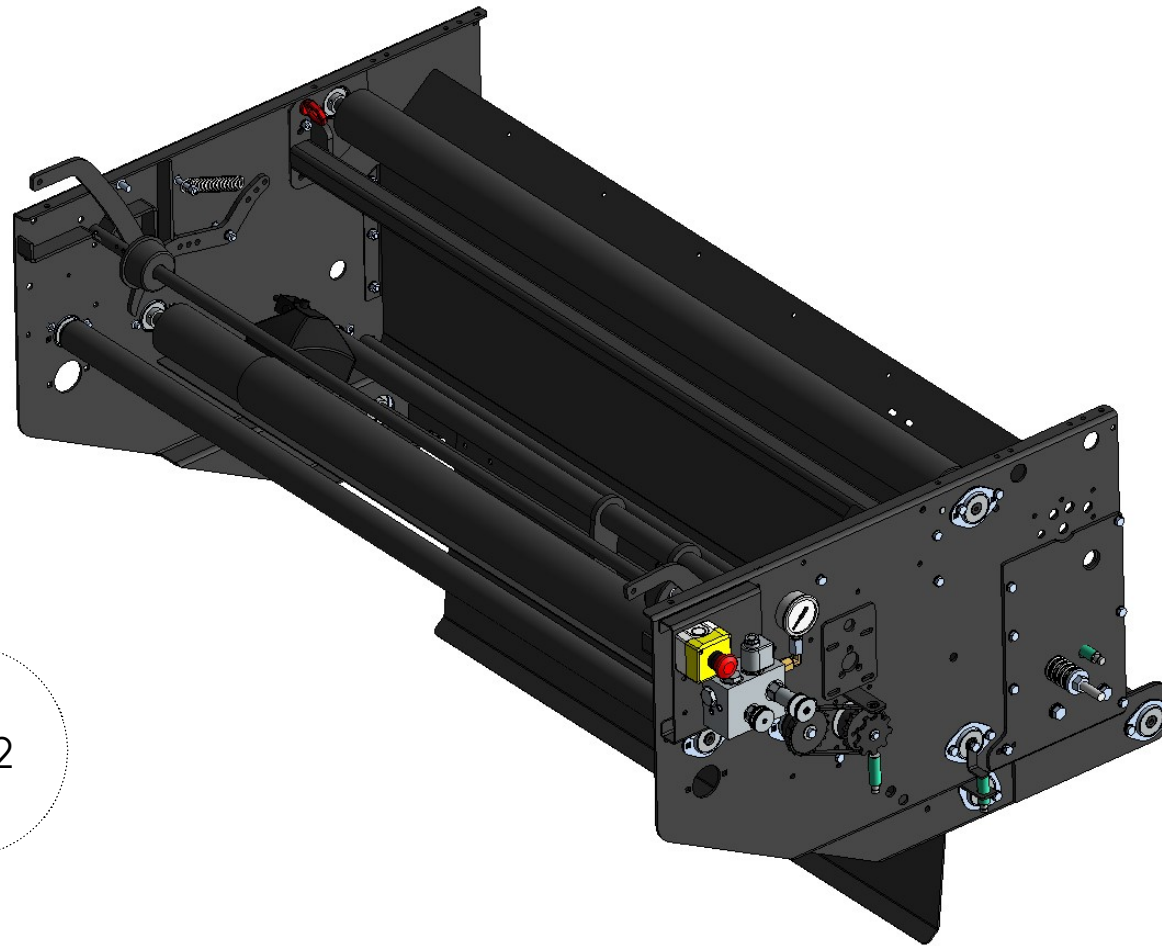

80432

Part number	Qty	Description
10217	1	Bolt M6x50
10244	26	Bolt M8 x 20 DIN 933 8.8 FZV
10248	6	Bolt M8 x 30 DIN 933 8.8 FZV
12047	109	Washer 8,4 DIN 125A -140HV FZV
12147	2	Washer 8,4 x 24 x 2 DIN 9021 FZV
12159	2	Washer 6,4 x 18 x 1,6 DIN 9021 FZV
12175	8	Washer ø40/17x6
12247	3	Spring washer 8,1 DIN 127 B FZV
13212	2	Lock nut M14
57537	12	Bearing SBPFL204
57798	1	Key 6x6x30
59055	1	Motor BGM32 C16SP
59177	1	Adaptor 3/8"-1/4"
59191	1	Coupling 1/4"
59318	1	Elbow 1/4" utv. 1/4" innv.
59405	2	Spring
59581	1	Flood light
59831	1	Chain 1/2"
77524	1	Guide roller, front plastic binding
77525	1	Guide roller, rear plastic binding
77526	1	Guide roller, upper plastic binding
77527	1	Brake roller
77530	1	Knife shaft
77602	1	Sprocket
77603	1	Sprocket
77605	1	Signalplate for sensor, knife
77607	1	Bracket, brake motor
77729	1	Spacer
77730	2	Seamless tube ø21,3x3,2
78735	1	Counting wheel
79702	1	Spacer, counting wheel, plastic tying unit

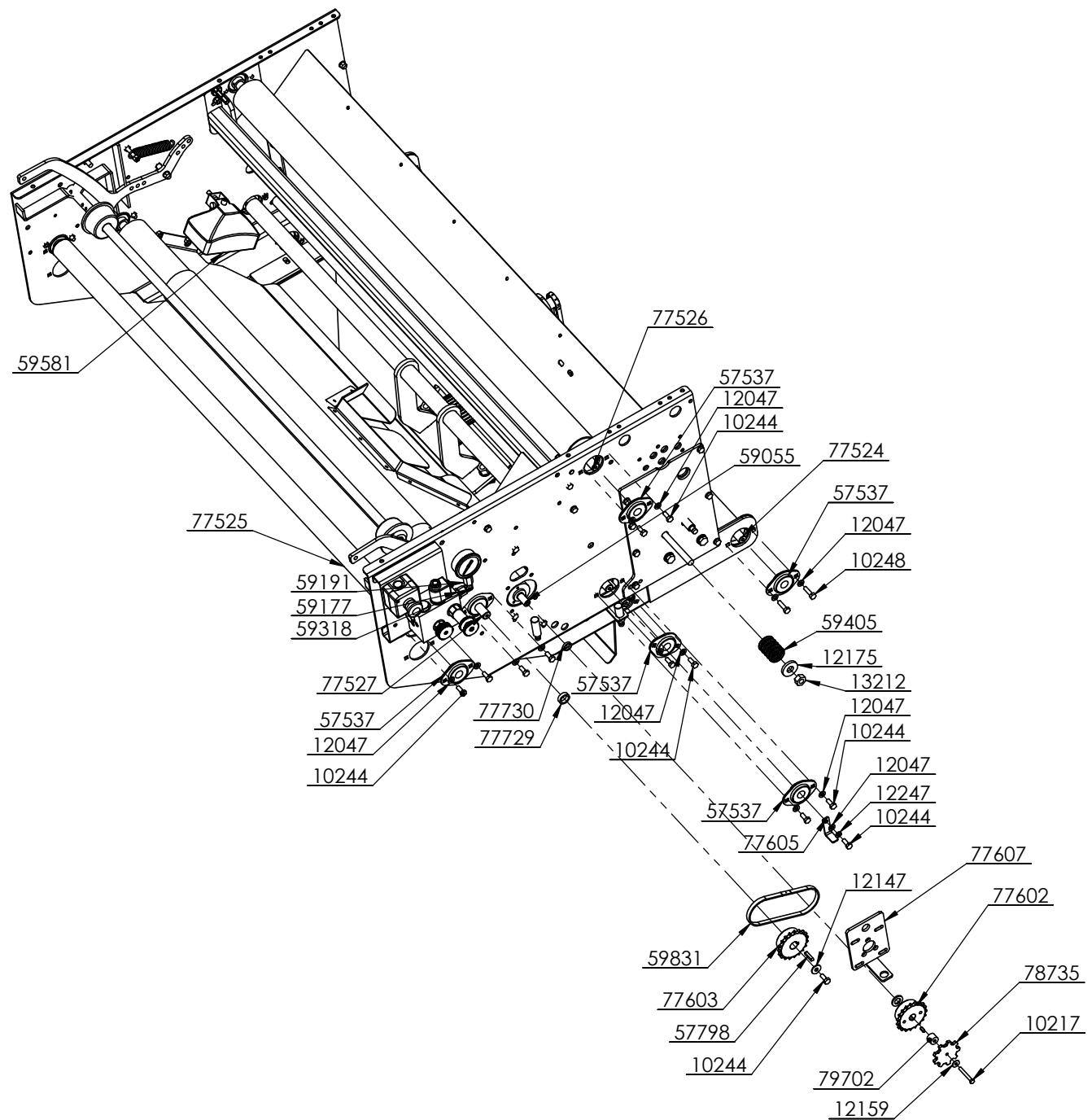

Part number	Qty	Description
10244	26	Bolt M8 x 20 DIN 933 8.8 FZV
10246	18	Bolt M8 x 25 DIN 933 8.8 FZV
10248	6	Bolt M8 x 30 DIN 933 8.8 FZV
10250	2	Bolt M8x35
10352	4	Bolt M12 x 40 DIN 933 8.8 FZV
12047	109	Washer 8,4 DIN 125A -140HV FZV
12067	8	Washer 13 DIN 125A -140HV FZV
12078	12	Washer 17 DIN 125A -140HV FZV
12175	8	Washer $\varnothing 40/17 \times 6$
12247	3	Spring washer 8,1 DIN 127 B FZV
13209	56	Lock nut M8
59405	2	Spring
77520	1	Right side wall
77521	1	Left side wall
77522	1	Middle plate, front
77523	1	Middle plate, rear
77538	1	Crossbar
77614	1	Bottom frame
77615	1	Middle plate, under
78037	1	Reinforcement, cylinder bracket, right
78734	1	Bracket for brake block and emergency stop

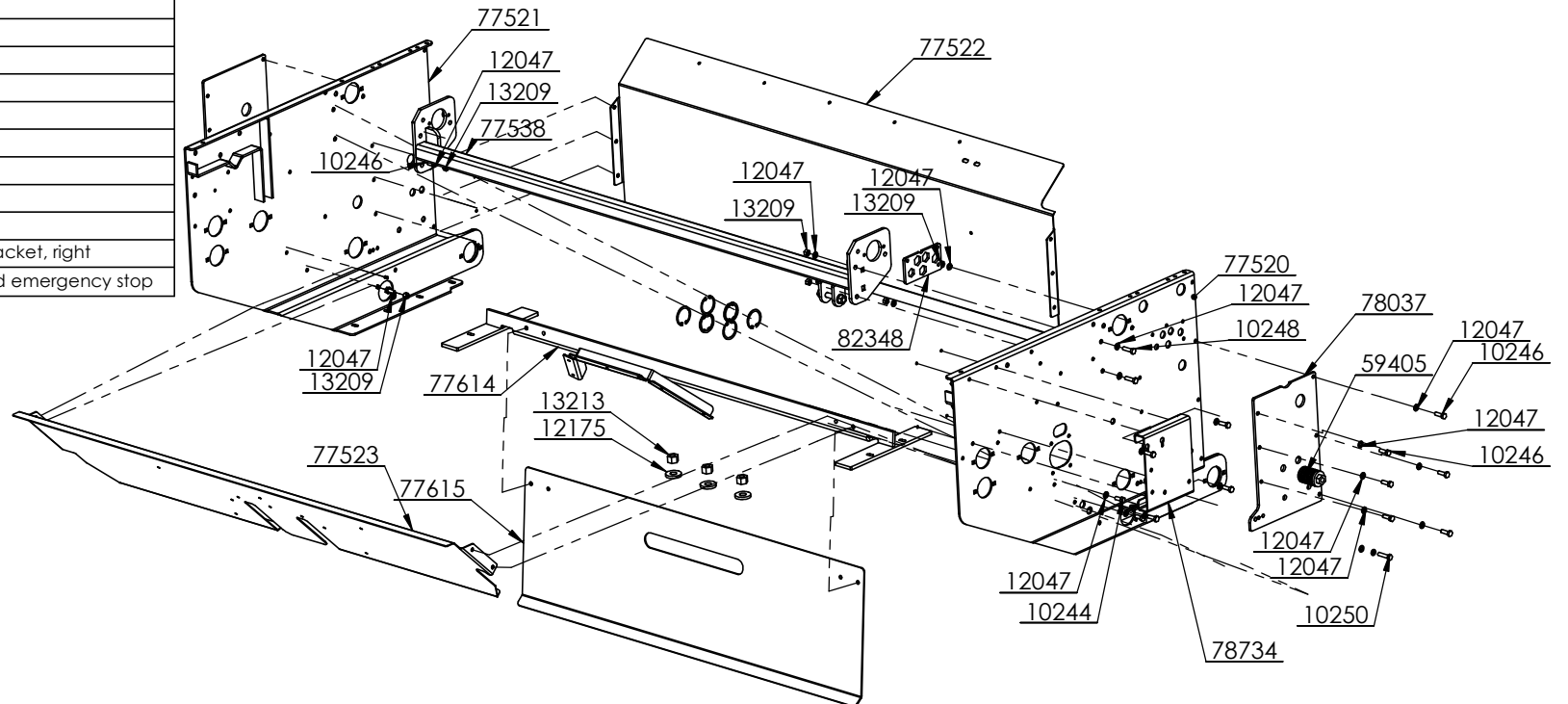

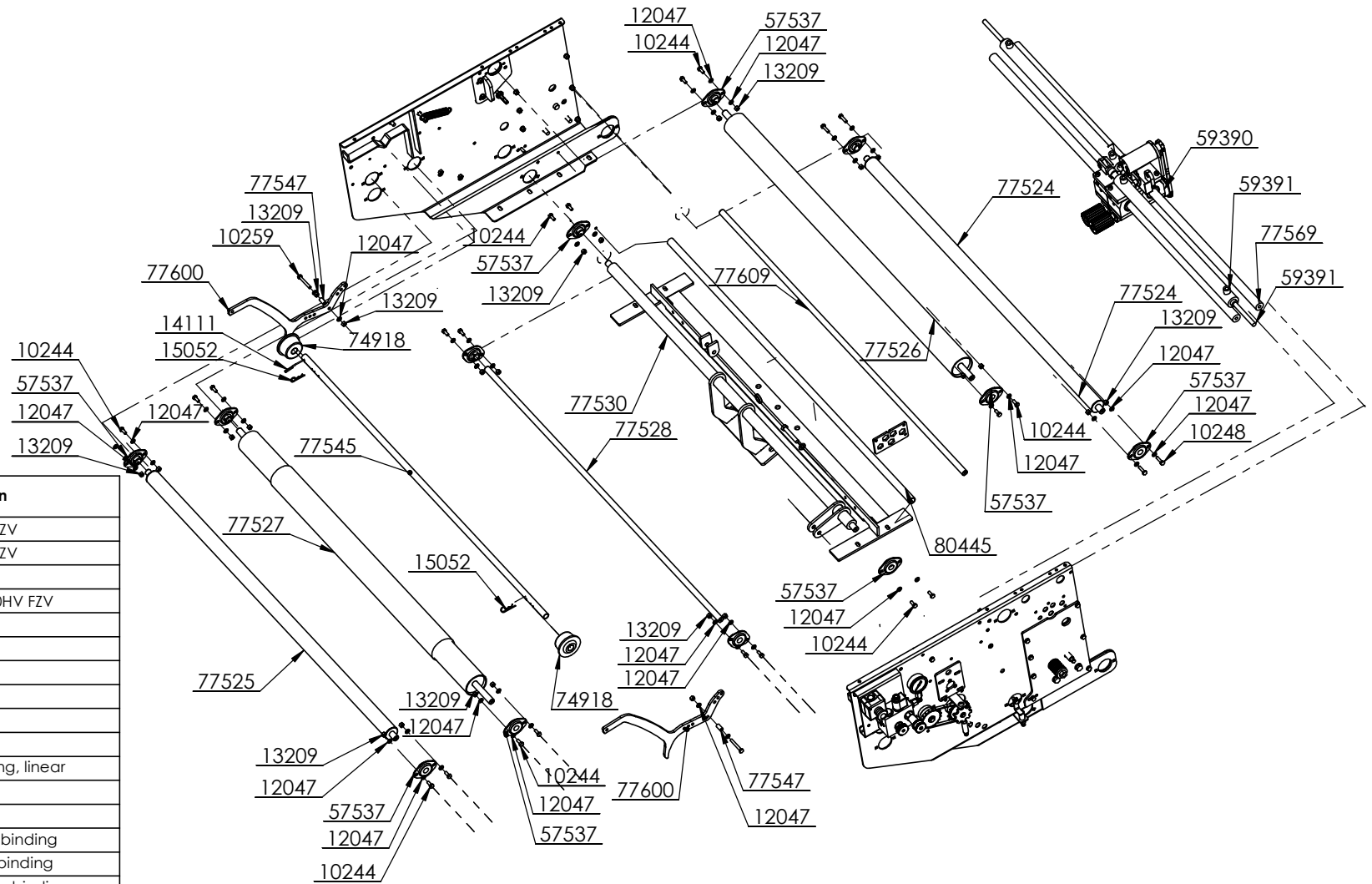

Part number	Qty	Description
10244	26	Bolt M8 x 20 DIN 933 8.8 FZV
10248	6	Bolt M8 x 30 DIN 933 8.8 FZV
10259	2	Bolt M8x60
12047	109	Washer 8,4 DIN 125A -140HV FZV
13209	56	Lock nut M8
14111	1	Splint ø6x30
15052	2	Hairpin M2,5
57537	12	Bearing SBPFL204
57539	2	Bearing housing PFT47
59055	1	Motor BGM32 C16SP
59390	4	Bearing housing w/bearing, linear
59391	2	Cylinder 32x20x620
74918	2	Plastic cone
77524	1	Guide roller, front plastic binding
77525	1	Guide roller, rear plastic binding
77526	1	Guide roller, upper plastic binding
77528	1	Guiding roller 1, plastic
77530	1	Knife shaft
77545	1	Tube for plastic roller
77547	2	Spacer, tightener
77569	2	Shaft, linear bearing
77600	2	Net roll tightener
77609	1	Guiding roller 2, plastic
80445	1	PVC tube

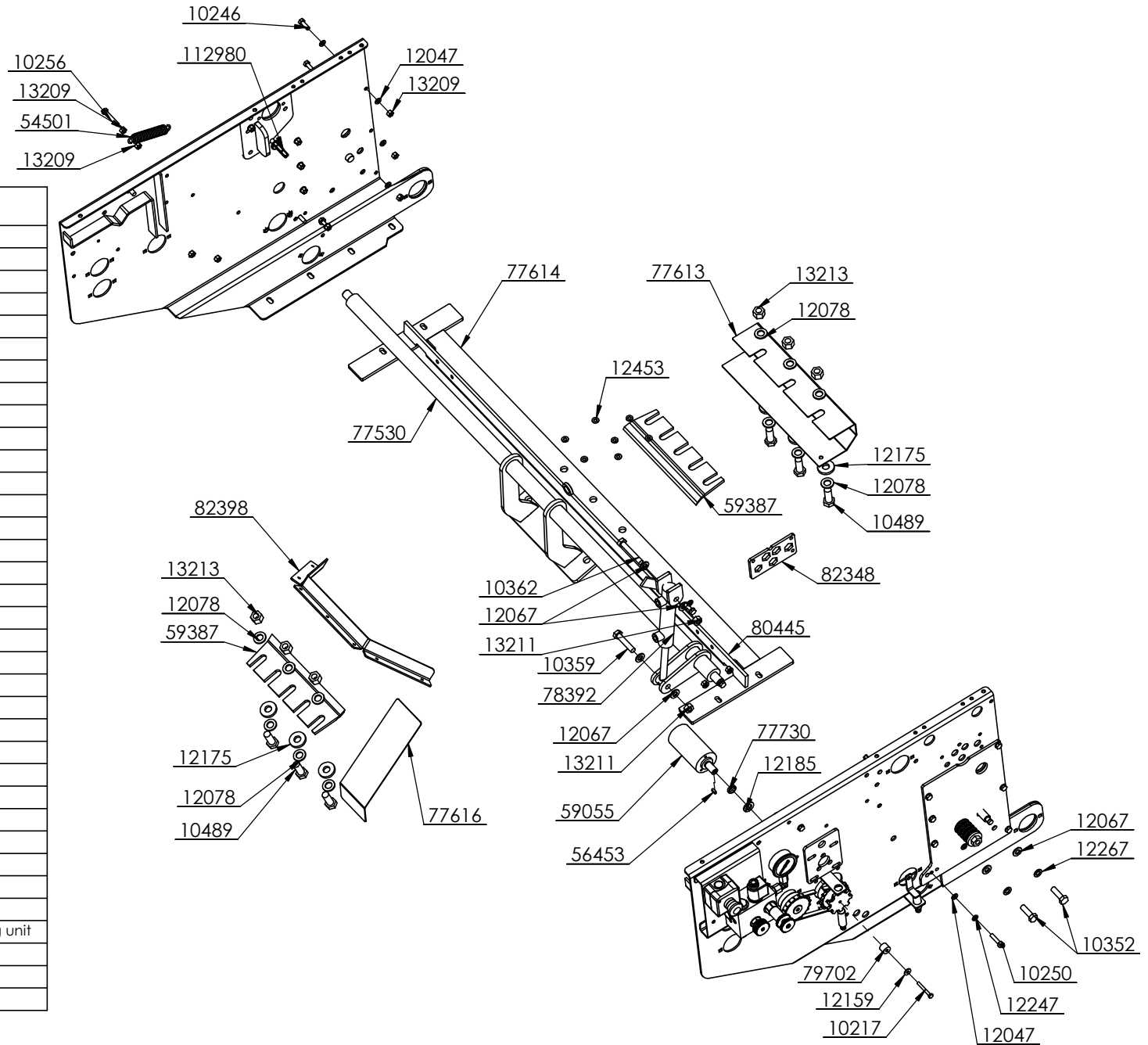

Part number	Qty	Description
10217	1	Bolt M6x50
10246	18	Bolt M8 x 25 DIN 933 8.8 FZV
10250	2	Bolt M8x35
10256	2	Bolt M8x50
10352	4	Bolt M12 x 40 DIN 933 8.8 FZV
10359	1	Bolt M12 x 60 DIN 931 8.8 FZV
10362	1	Bolt M12 x 75 DIN 931 8.8 FZV
10489	6	Bolt M16 x 40 DIN 933 8.8 FZV
112980	2	Lifting point
12047	109	Washer 8,4 DIN 125A -140HV FZV
12067	8	Washer 13 DIN 125A -140HV FZV
12078	12	Washer 17 DIN 125A -140HV FZV
12159	2	Washer 6,4 x 18 x 1,6 DIN 9021 FZV
12175	8	Washer ø40/17x6
12185	1	Washer ø28/16x3
12247	3	Spring washer 8,1 DIN 127 B FZV
12267	4	Spring washer 12,2 DIN 127 B FZV
12453	7	Nord-Lock washer M8
13209	56	Lock nut M8
13211	2	Lock nut M12
13213	6	Lock nut M16
54501	2	Spring ø23/ø17x120
56453	1	Parallel Key 5x5x14
59055	1	Motor BGM32 C16SP
59387	2	Knife
78392	1	Cylinder, outer 35x15x19
77530	1	Knife shaft
77613	1	Cover, behind plastic knife
77614	1	Bottom frame
77616	1	Cover, brake motor
77730	2	Seamless tube ø21,3x3,2
79702	1	Spacer, counting wheel, plastic tying unit
80445	1	PVC tube
82348	1	Bulkhead plate
82398	1	Stringer

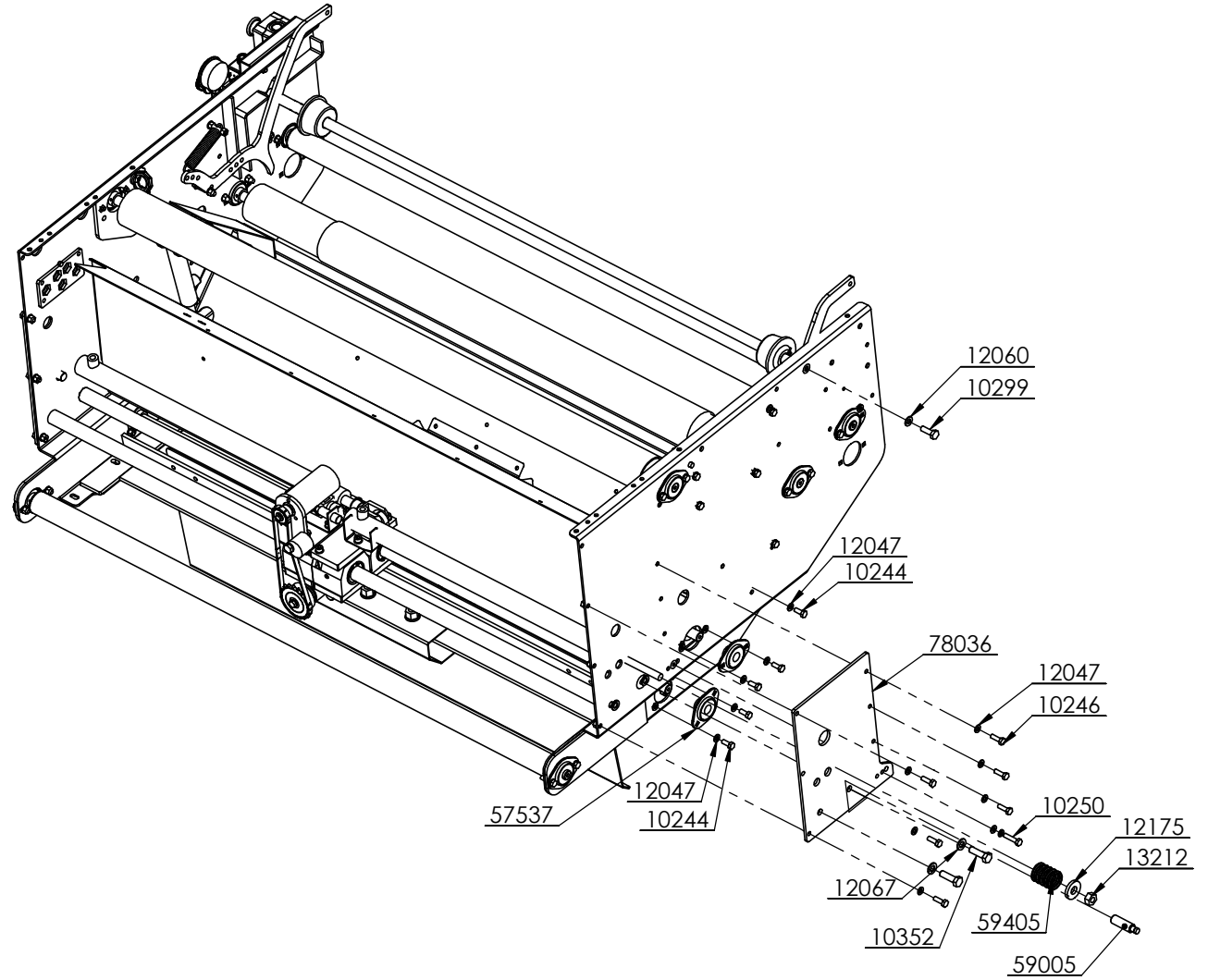
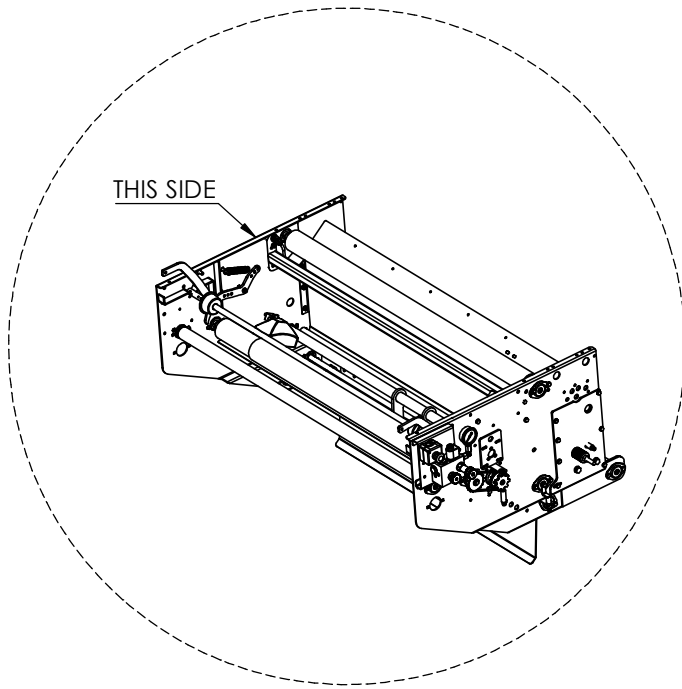

Part number	Qty	Description
10244	26	Bolt M8 x 20 DIN 933 8.8 FZV
10246	18	Bolt M8 x 25 DIN 933 8.8 FZV
10250	2	Bolt M8x35
10299	1	Bolt M10 x 30 DIN 933 8.8 FZV
10352	4	Bolt M12 x 40 DIN 933 8.8 FZV
12047	109	Washer 8,4 DIN 125A -140HV FZV
12060	4	Washer 10,5 DIN 125A -140HV FZV
12067	8	Washer 13 DIN 125A -140HV FZV
12175	8	Washer \varnothing 40/17x6
12247	3	Spring washer 8,1 DIN 127 B FZV
13212	2	Lock nut M14
57537	12	Bearing SBPFL204
59005	5	Inductive transducer
59405	2	Spring
78036	1	Reinforcement, cylinder bracket, left

Part number	Qty	Description
10201	1	Bolt M6x16, threaded to head
10244	26	Bolt M8 x 20 DIN 933 8.8 FZV
10310	1	Bolt M10 x 60 DIN 931 8.8 FZV
10352	4	Bolt M12 x 40 DIN 933 8.8 FZV
12047	109	Washer 8,4 DIN 125A -140HV FZV
12060	4	Washer 10,5 DIN 125A -140HV FZV
12067	8	Washer 13 DIN 125A -140HV FZV
12147	2	Washer 8,4 x 24 x 2 DIN 9021 FZV
12159	2	Washer 6,4 x 18 x 1,6 DIN 9021 FZV
12175	8	Washer $\varnothing 40/17 \times 6$
13210	3	Lock nut M10
13212	2	Lock nut M14
15504	1	Circlip A20x1,2
54829	2	Bearing 6004 2RS
59005	5	Inductive transducer
59391	2	Cylinder 32x20x620
59396	1	Motor BGM50 C16SP
59397	2	Bearing 6804 2RS
59399	1	Bearing ZZ 6204 P, one-way
59405	2	Spring
59409	2	Fork head
59827	1	Chain 1/2"
59828	2	Chain lock 1/2"
77531	1	Bracket for bearings, driveshaft
77533	1	Cylinder fastener, driveshaft
77534	1	Cylinder fastener, impeller
77537	1	Bracket for bearings, impeller
77542	1	Sprocket 08B z10
77543	1	Sprocket 08B z19
77544	1	Chain tightener
77548	1	Spacer, driveshaft
77549	1	Sensor bracket 1
77550	1	Sensor bracket 2
77551	1	Driveshaft feeding sprocket
77552	1	Impeller, feeding
77553	1	Driveshaft
77569	2	Shaft, linear bearing
77730	2	Seamless tube $\varnothing 21,3 \times 3,2$
15164	8	Bolt M10 x 100 ISO 4762

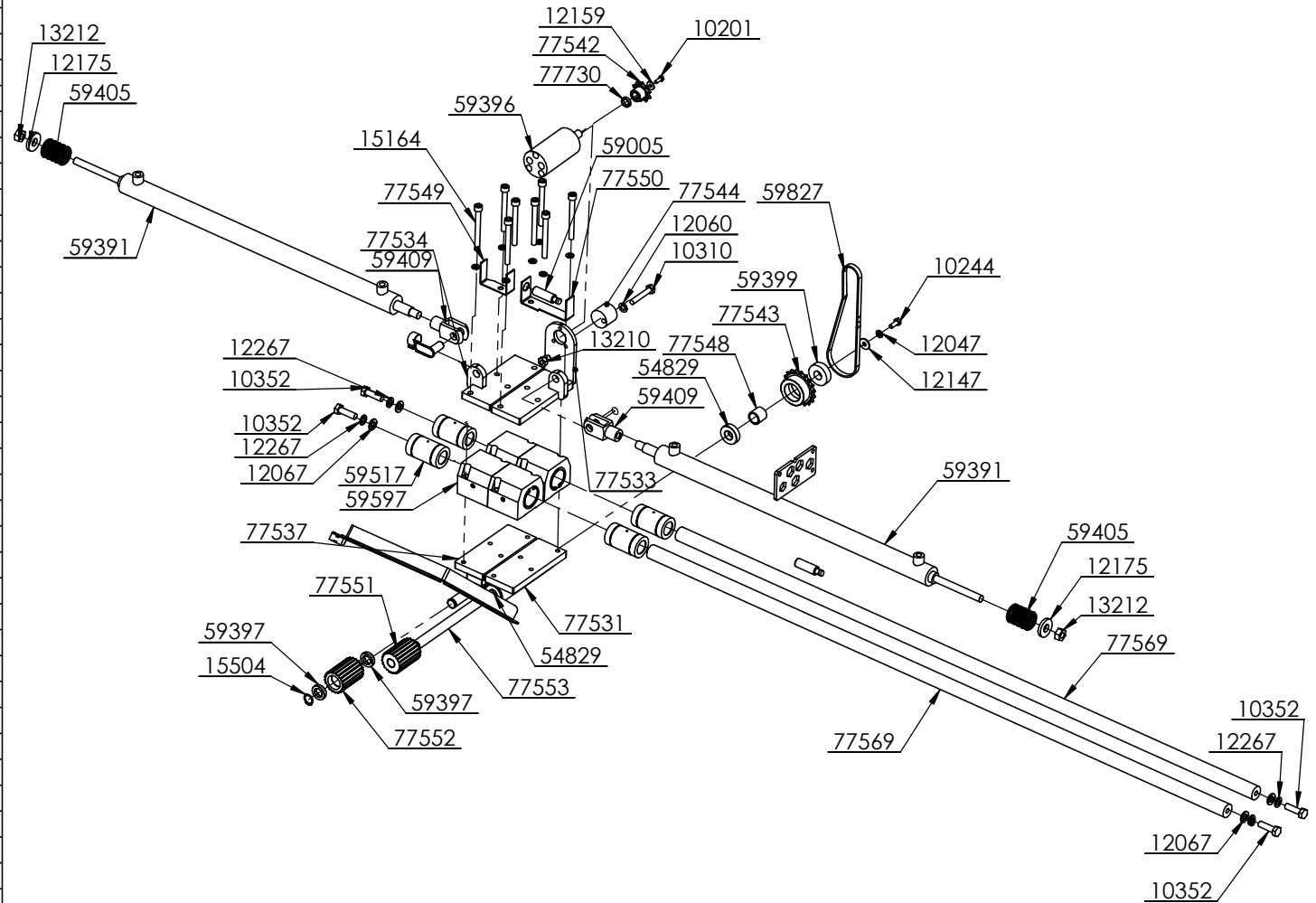

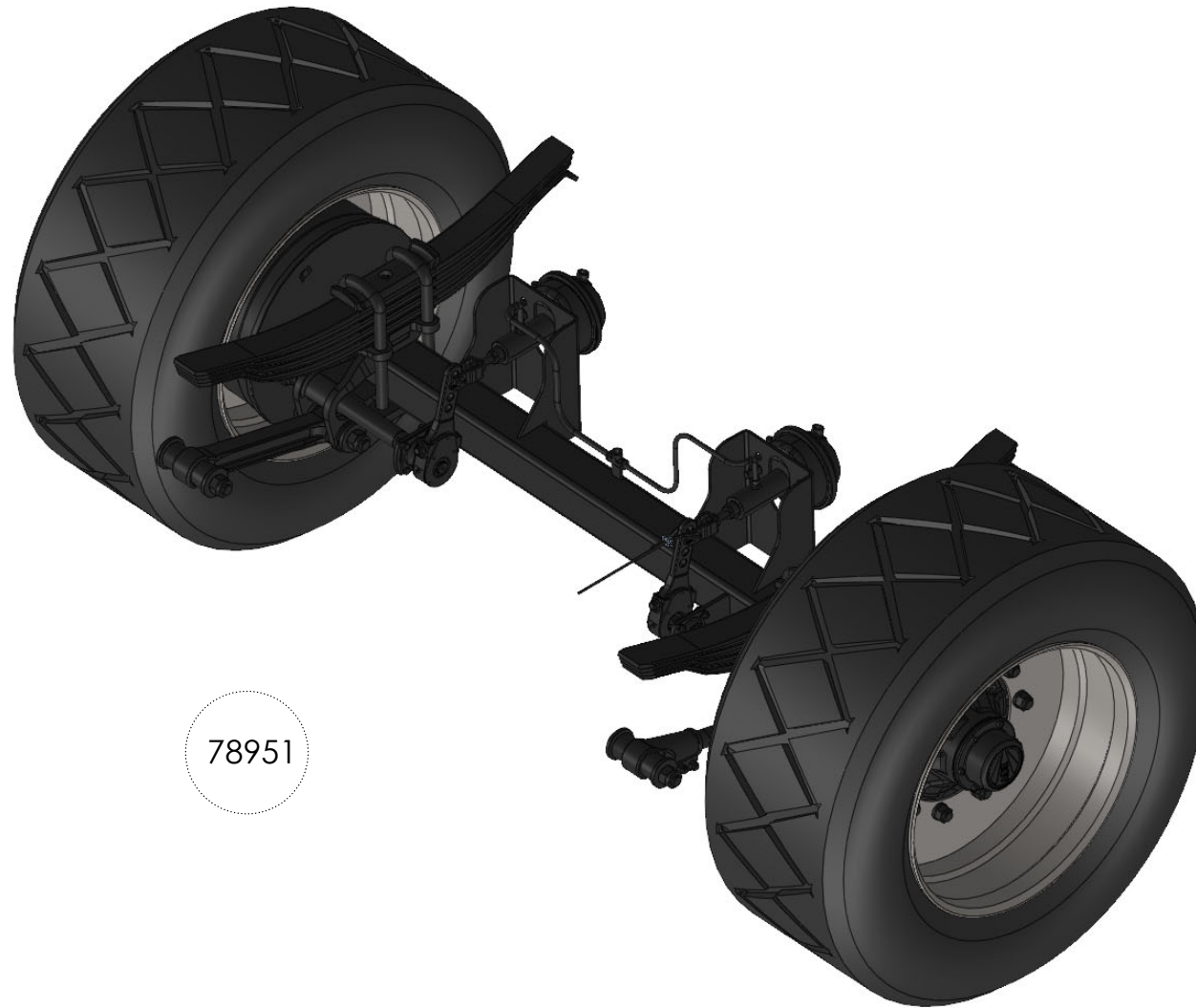

78951

Part number	Qty	Description
14414	1	Wire Ø5
59313	2	Wire guide
59342	9	Wire clamp 5 mm
59700	2	Combi Air/Hydr. Brake T20
78952	1	Axle 10 bolt
80571	2	Leaf spring
80719	2	Wheel 385/65R22,5 10 bolts
59768	1	Torque arm fixed
59769	1	Torque arm adjustable
59765	2	Bottom plate for leaf spring
59762	4	U-bolt
59763	2	Top plate for leaf spring
80729	8	Washer
80730	8	Nut
59309	2	Hydraulic hose 1/4" L=390

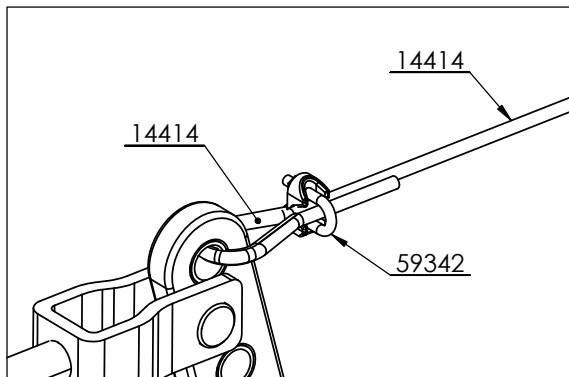
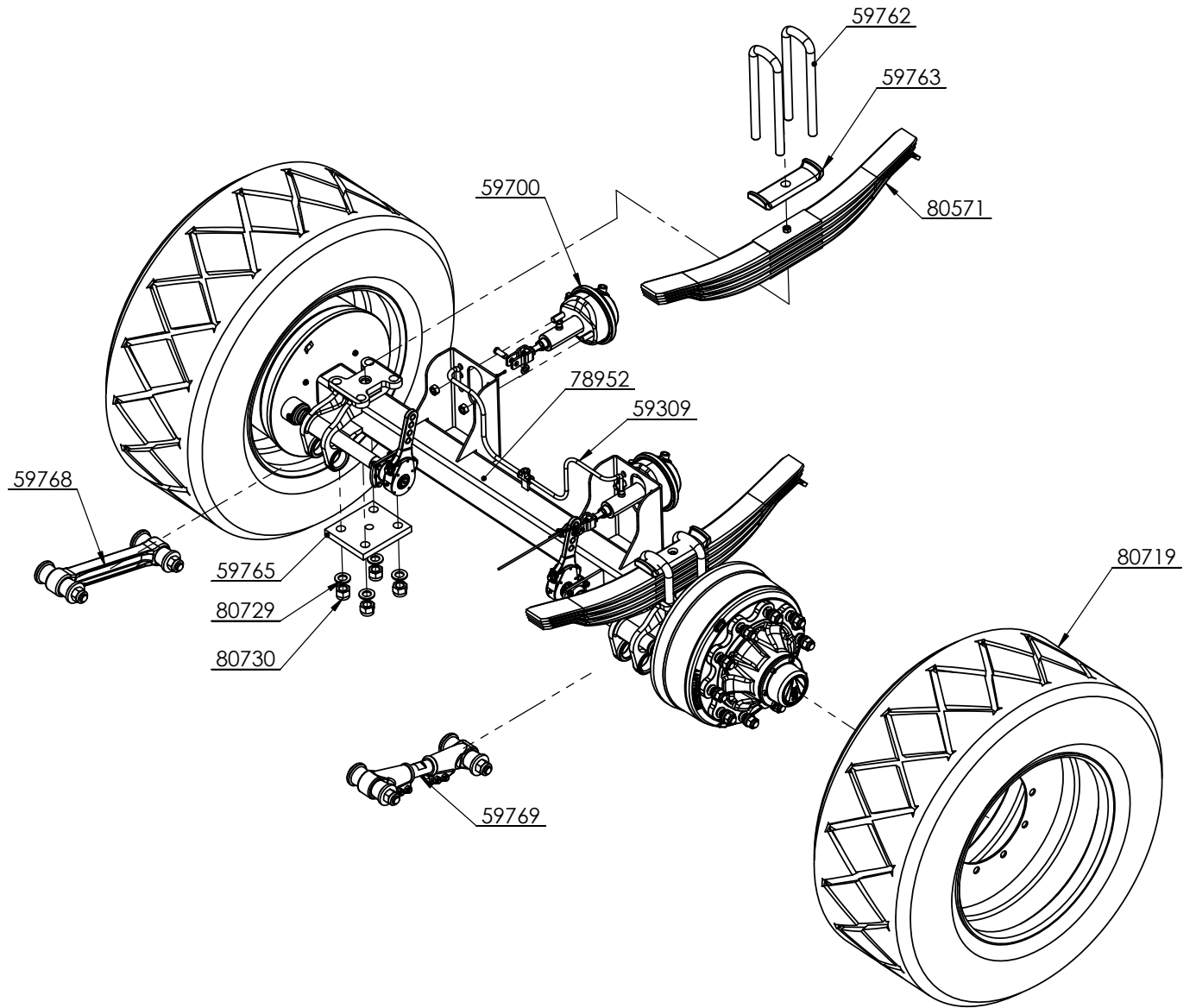

78747



Part number	Qty	Description
10220	8	Bolt M6 x 60 DIN 931
10240	2	Bolt M8 x 16 DIN 933 8.8 FZV
10297	32	Bolt M10 x 25 DIN 933 8.8 FZV
10299	5	Bolt M10 x 30 DIN 933 8.8 FZV
10348	2	Bolt M12 x 30 DIN 933 8.8 FZV
10352	8	Bolt M12 x 40 DIN 933 8.8 FZV
10359	2	Bolt M12 x 60 DIN 931 8.8 FZV
12036	12	Washer 6,4 DIN 125A -140HV FZV
12047	24	Washer 8,4 DIN 125A -140HV FZV
12060	57	Washer 10,5 DIN 125A -140HV FZV
12067	32	Washer 13 DIN 125A -140HV FZV
12078	3	Washer 17 DIN 125A -140HV FZV
12146	53	Washer 10,5x30x2,5 DIN 9021 FZV
12173	4	Washer ø24/8,4x2
13009	2	Nut M8
13208	2	Lock nut M6
13209	26	Lock nut M8
13210	37	Lock nut M10
13211	12	Lock nut M12
14126	1	Splint M4x32
15162	2	Bolt M6x25 Din 912
57660	1	Spring, ø21/15, L=107, N=24
59248	4	Top plate for plastic clamp
59325	8	Plastic clamps 35 mm
59701	9	Step
78661	2	Supporting bow
78737	1	Siderail - Upper, Right
78738	1	Siderail - Upper, Left
78739	1	Siderail - Lower, Right
78740	1	Siderail - Lower, Left
78742	1	Block plate
78743	2	Rail
78744	4	Arm, upper
78745	2	Arm, lower
78746	1	Lock arm
78748	3	Clamp lock
78823	1	Fastening bracket for staircase, lower
78897	2	Telescope, upper
78898	2	Telescope, lower
80560	13	U-clamp 42mm

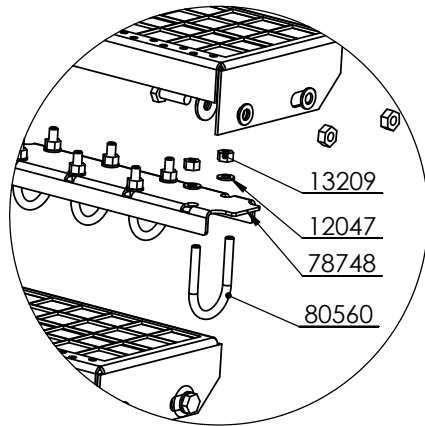

DETAIL A

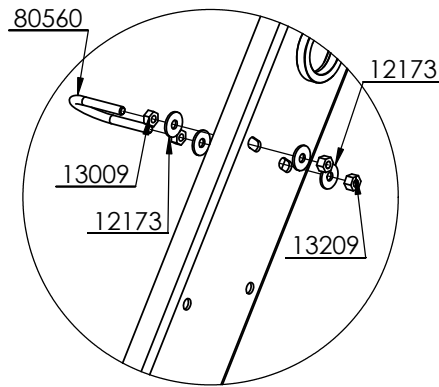

DETAIL B

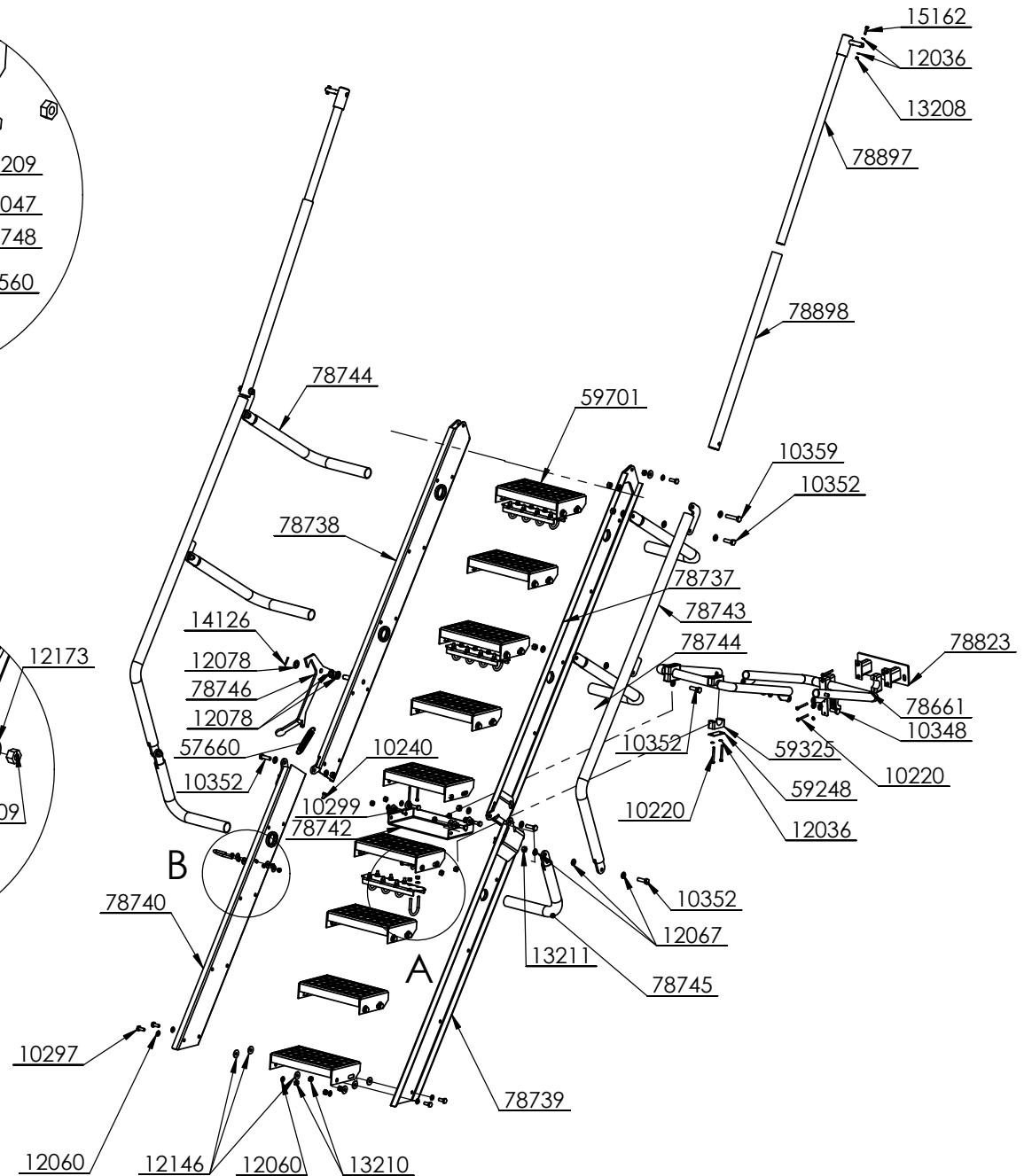

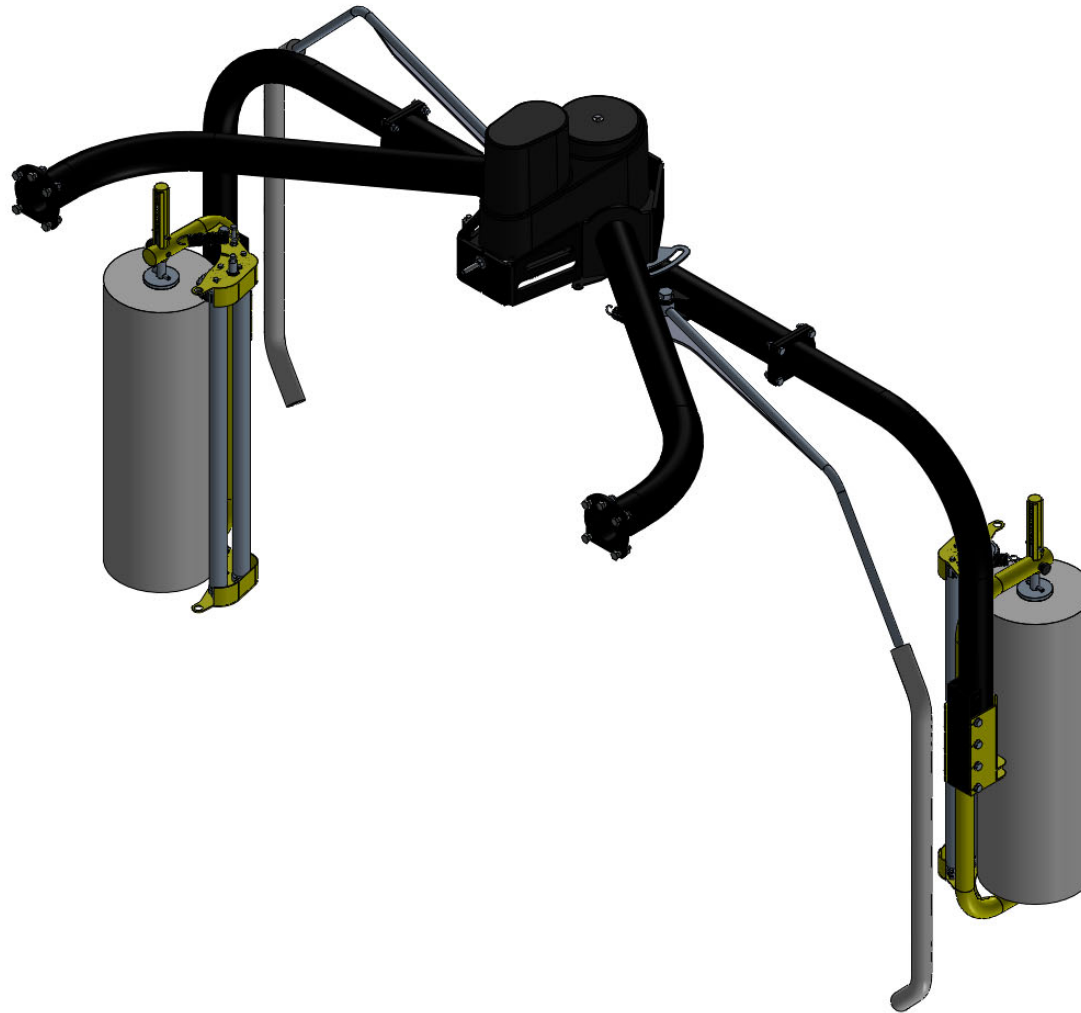

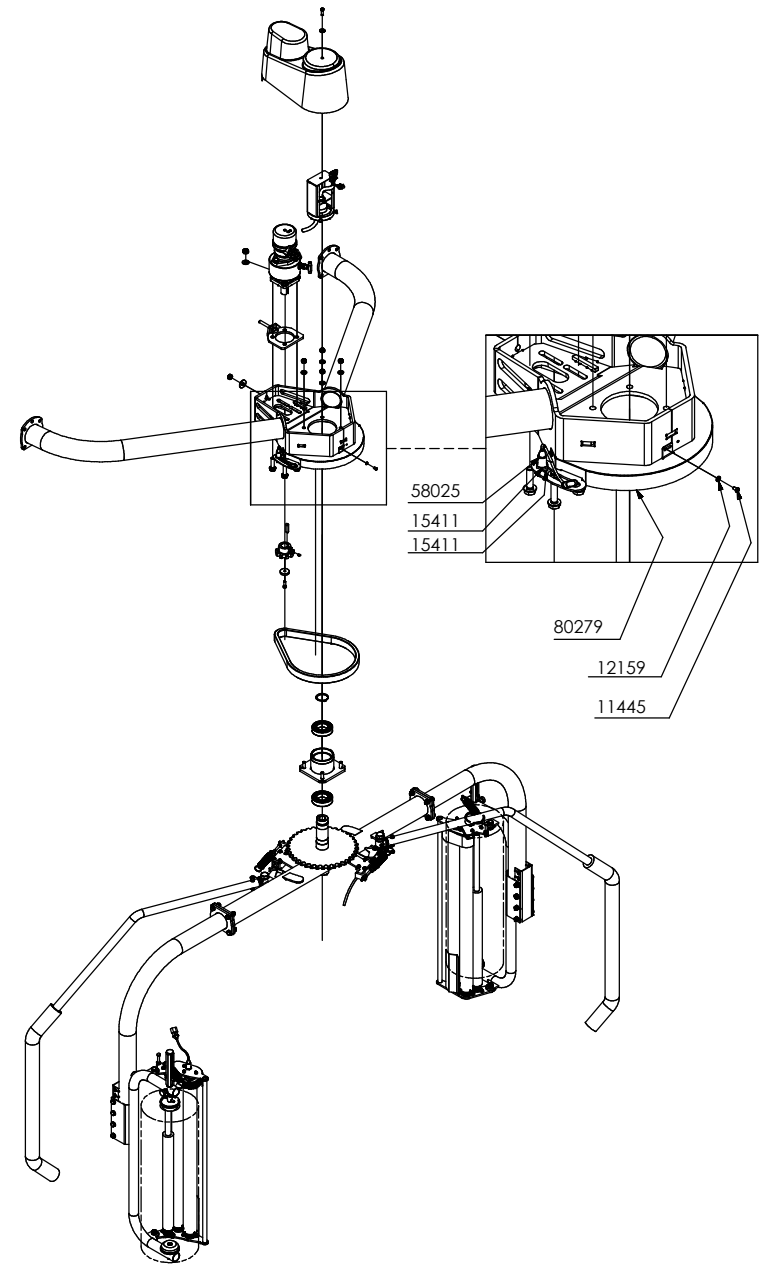
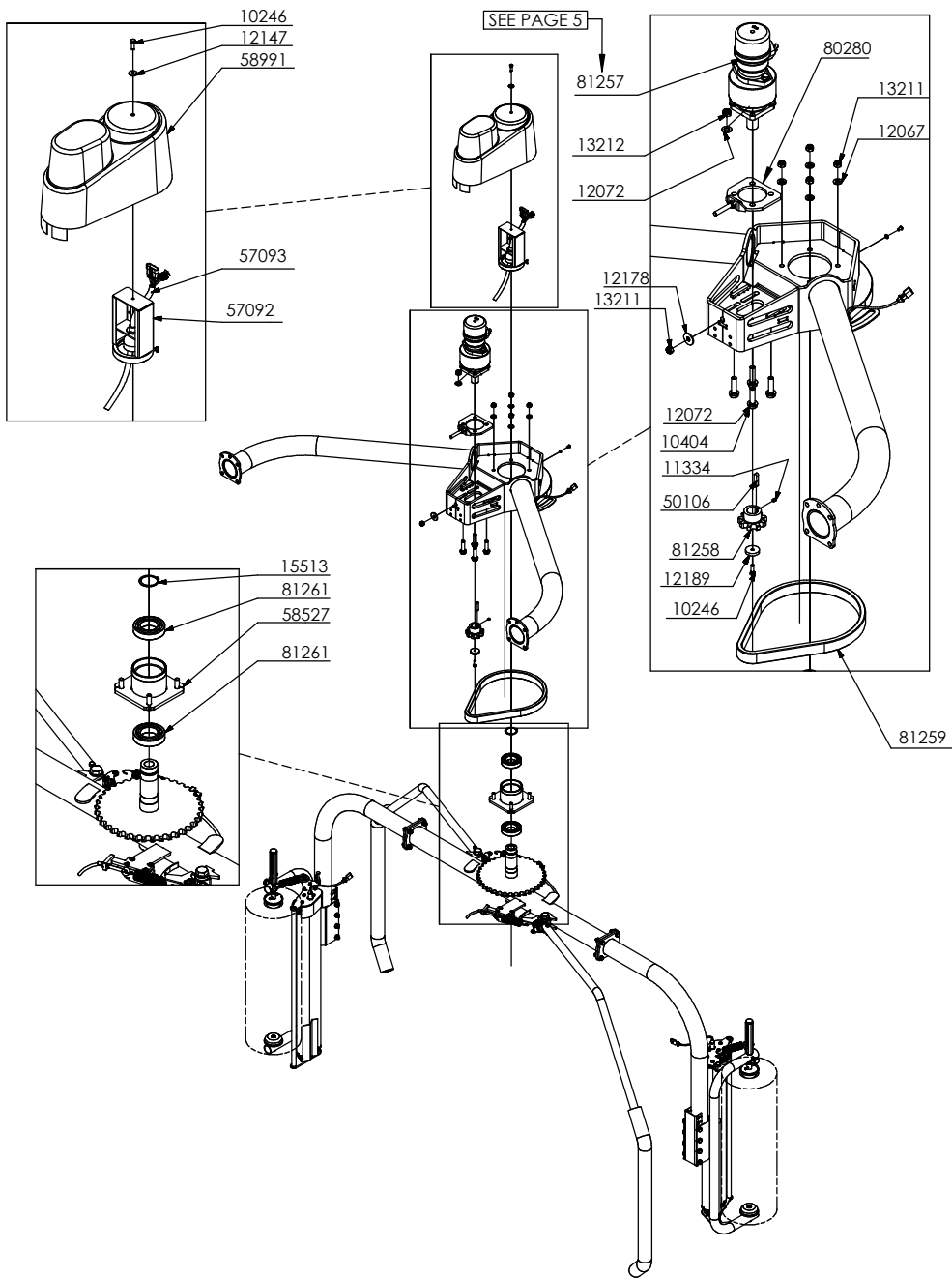

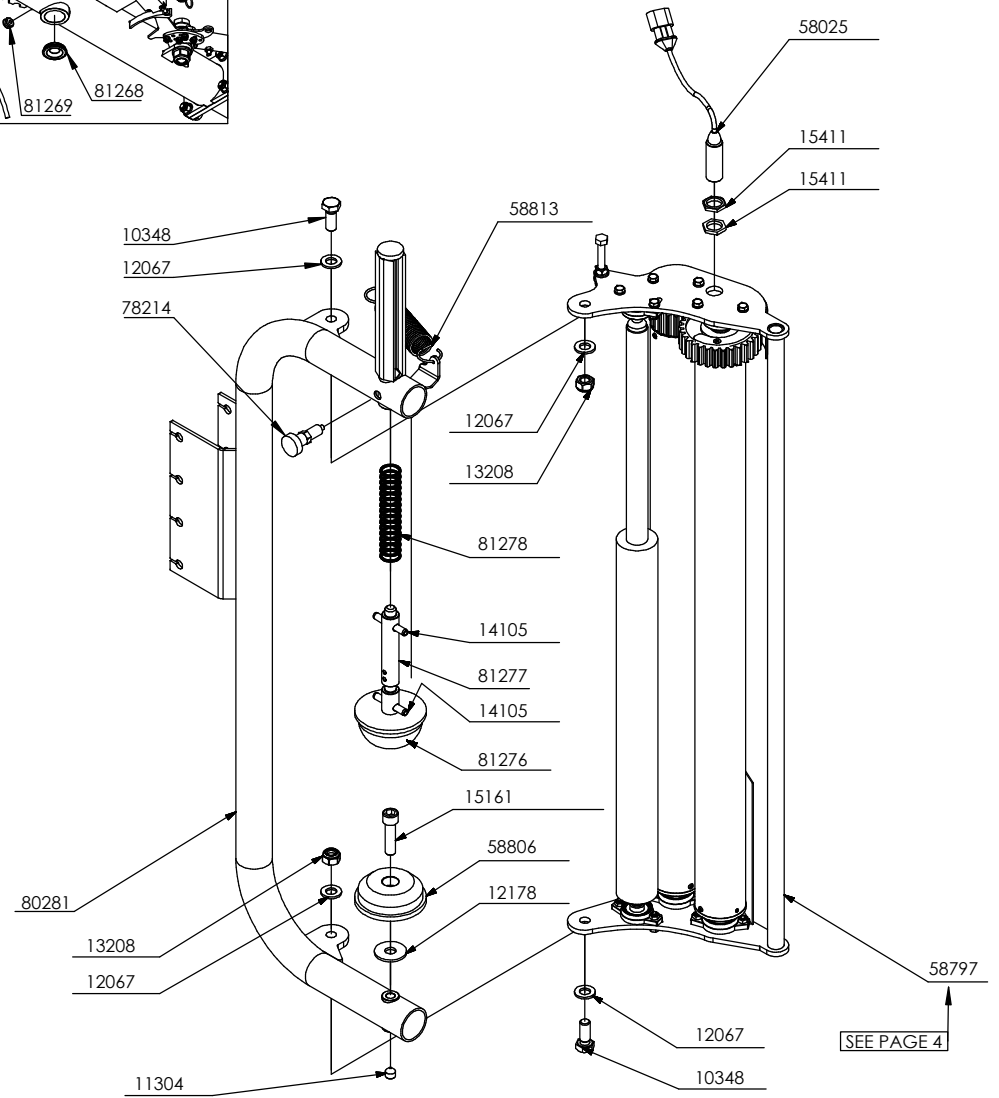
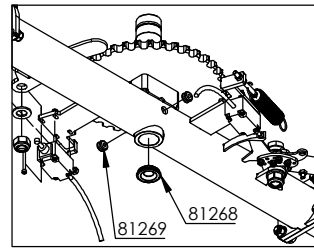
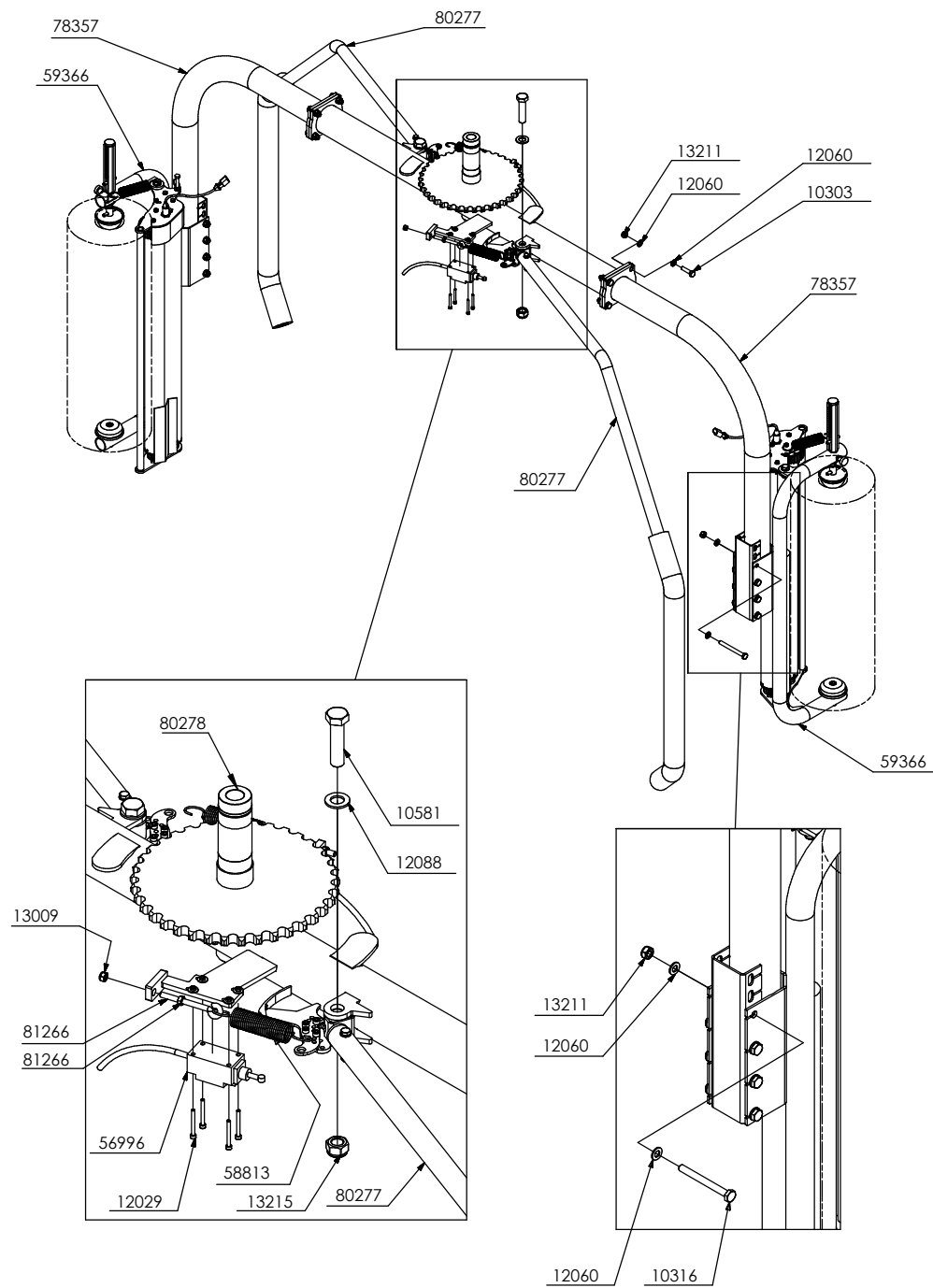

SEE PAGE 4



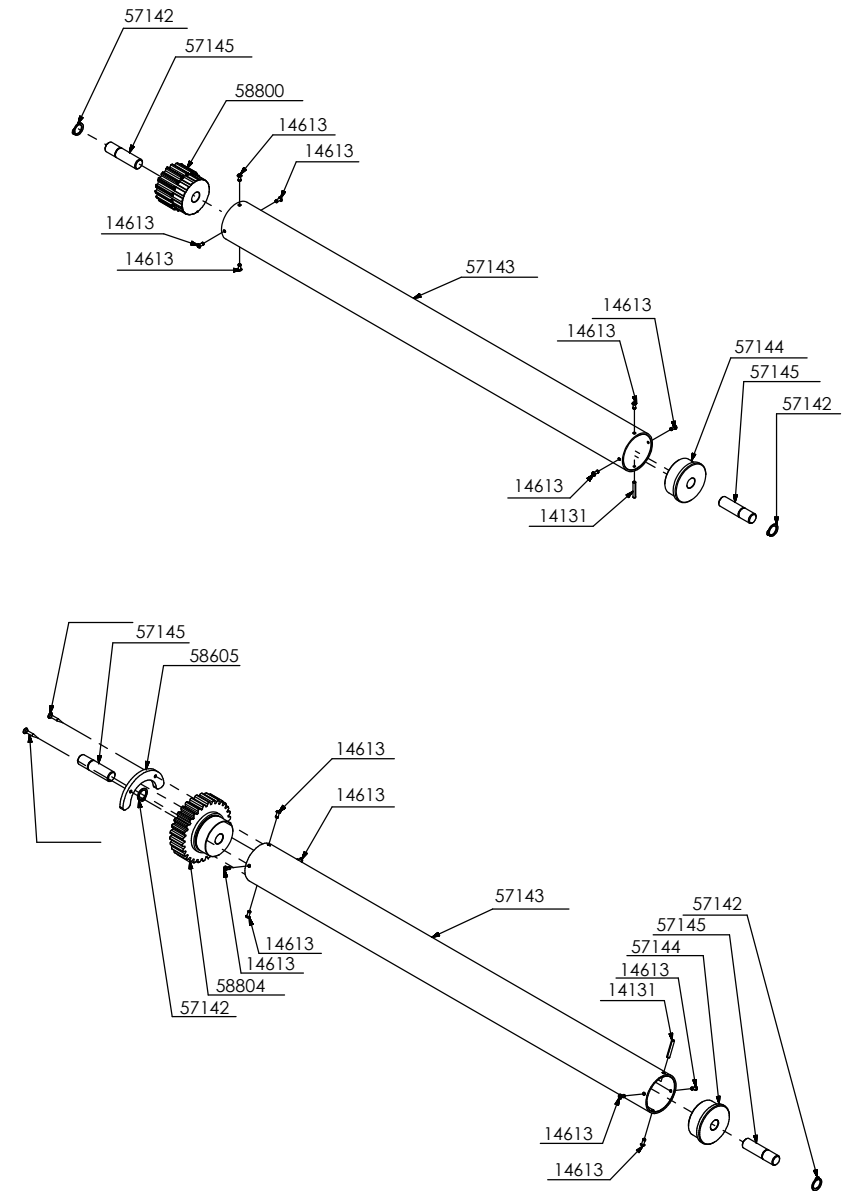
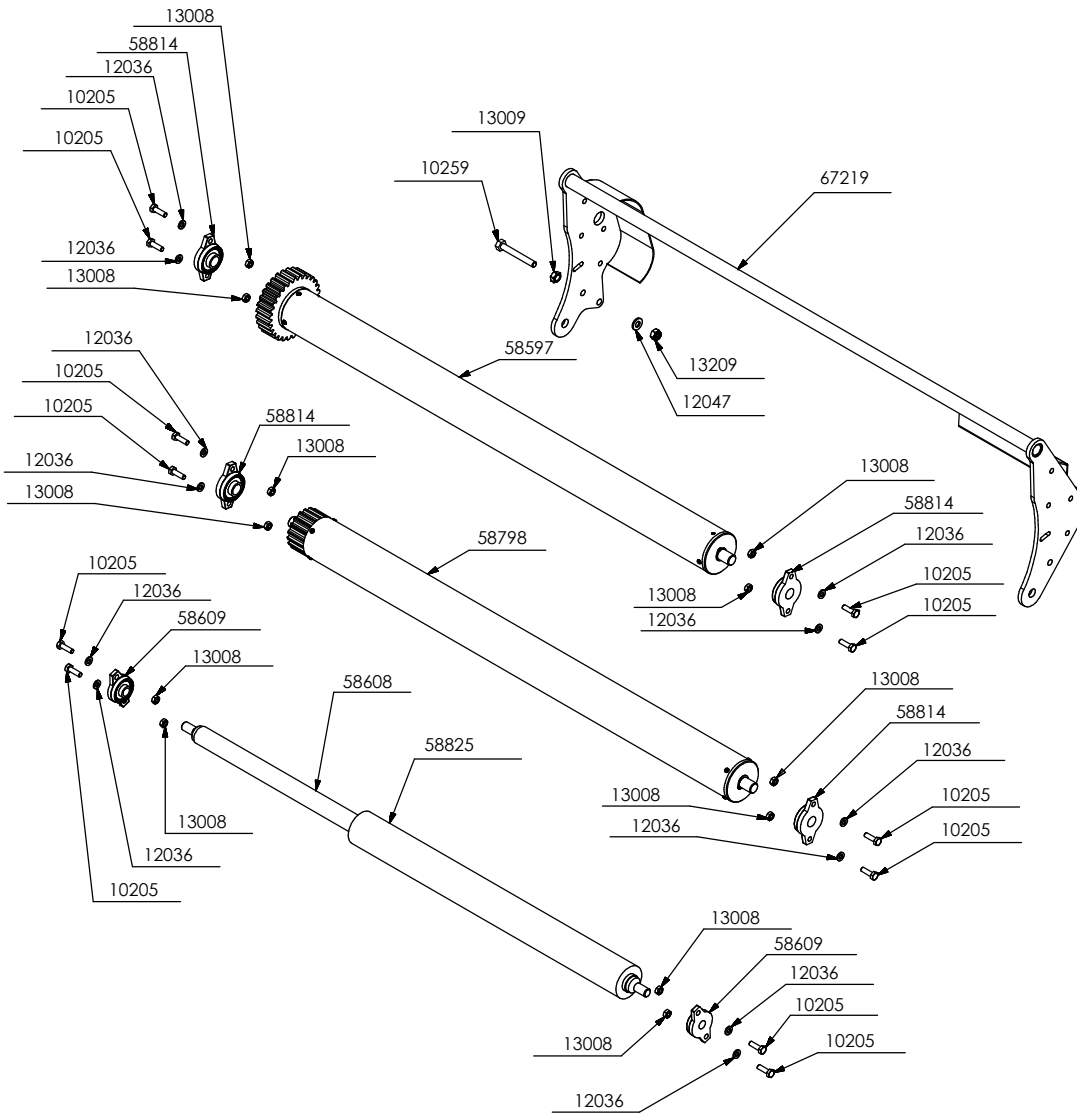

Mounted on frame
81073 Valve block assembly with 24V coil

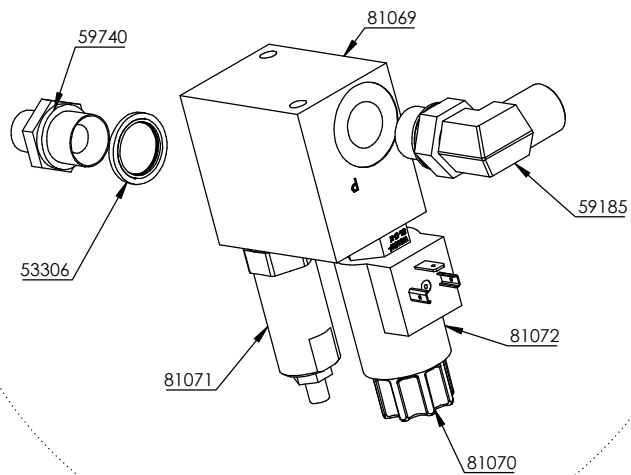

81257
Wrapping
motor
assembly

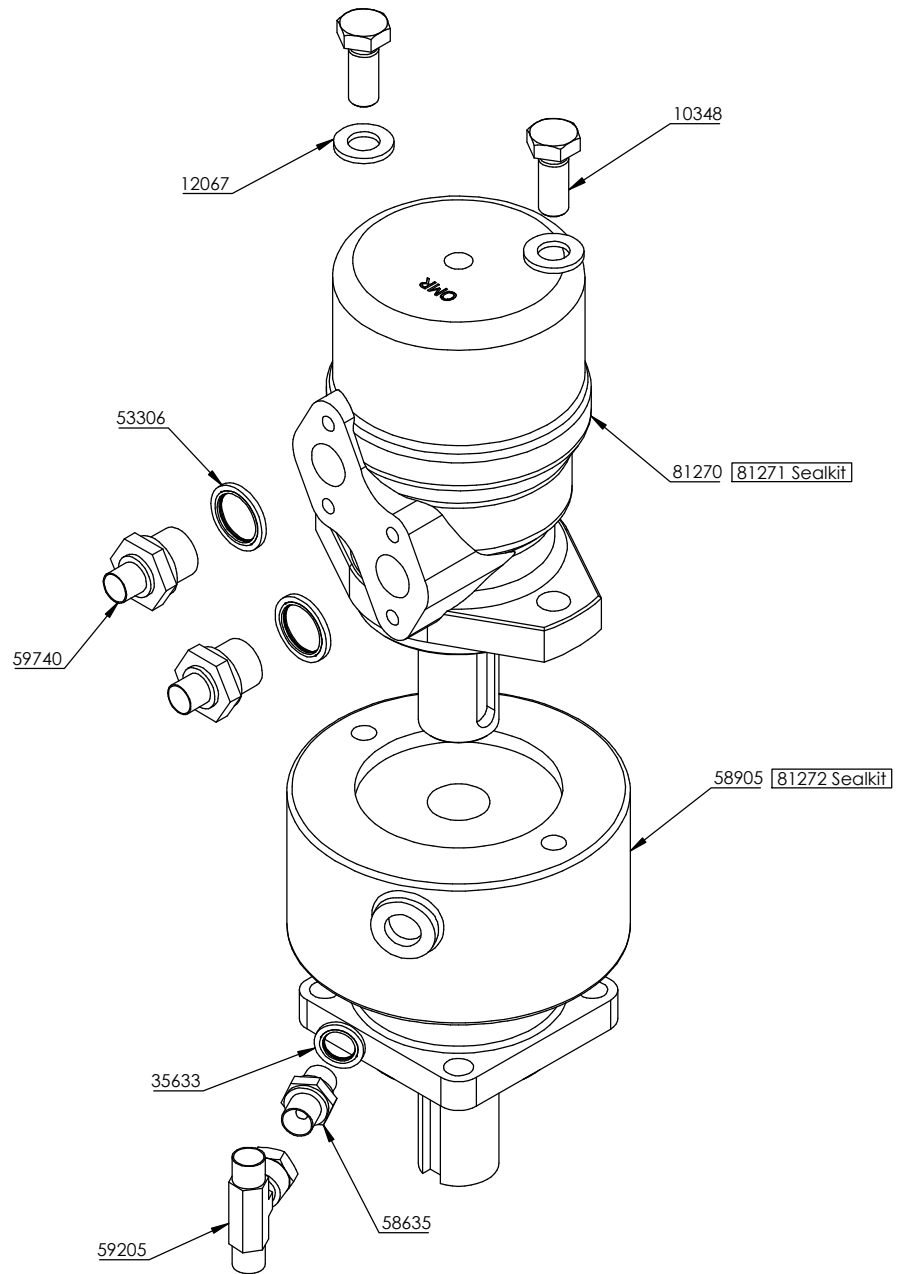

PART NUMBER	QTY.	DESCRIPTION
10205	12	Bolt M6x20
10246	2	Bolt M8x25
10259	1	Bolt M8x60
10303	8	Bolt M10x40
10316	8	Bolt M10x100
10348	6	Bolt M12x30
10404	4	Bolt M14x55, DIN 933
10581	2	Bolt M20x80
11304	2	Set screw M12x45
11334	1	Set screw M8x10
11445	3	Bolt M6x10
12029	8	Washer M5
12036	12	Washer M6
12047	2	Washer M8
12060	32	Washer M10
12067	14	Washer M12
12072	8	Washer M14
12088	2	Washer M20
12147	1	Washer ø24/8,4x2
12159	3	Washer ø18/6,4
12178	3	Washer ø37/13x3
12189	1	Washer ø40/9x4
13008	12	Nut M6
13009	3	Nut M8
13208	4	Lock nut M6
13209	1	Lock nut M8
13211	21	Lock nut M12
13212	4	Lock nut M14
13215	2	Lock nut M20
13624	2	Screw 3,5 x 25
14105	4	Splint ø8x50
14131	2	Spring pin 4x26 DIN 1481
14613	14	Pop-rivet 3,2 x 10
15161	2	Bolt M12x45, cylinderhead
15411	6	Lock nut M18
15513	1	Circlip A50x2,0
35633	1	Bonded seal 1/4"
50106	1	Key 10x8x45
53306	3	Gasket 1/2

56996	2	Stop switch
57092	1	Bracket, charcoal
57093	1	Slip ring module
57142	4	Spring retaining ring
57143	2	Roll tube
57144	2	Roll head
57145	4	Shaft
58025	3	Inductive Sensor M18 with cable
58527	1	Bearing housing
58597	1	Tension roller
58605	1	Inductive sensor, transducer
58608	1	Clamp roller
58609	2	Bearing UFL000N
58635	1	Fitting 1/4"-1/4"
58797	2	Roller frame compl.
58798	1	Drive roller
58800	1	Sprocket
58804	1	Sprocket
58806	2	Bearing, lower
58813	4	Spring
58814	4	Bearing UFL002N
58825	1	Soft roll
58905	1	Brake, wrapping arms
58991	1	Upper housing
59185	1	Fitting 1/2 - 1/2
59205	1	BSP Tee 1/4
59366	2	Film stretcher, complete
59740	3	Fitting 1/4 - 1/2
67219	1	Film stretcher, frame for rollers
78214	2	Fastening bolt M10, film stretcher
78357	2	Rotation arm
80277	2	Emergency stop arm
80278	1	Rotating arms, axle
80279	1	Chain guard
80280	1	Adjusting plate M14
80281	2	Film stretcher, frame
81069	1	Housing
81070	1	Cartridge valve WS10W
81071	1	Safety valve
81072	1	Coil for WS10W, 24V

81073	1	Valve block assembly, with 24V coil
81257	1	Wrapping motor assembly
81258	1	Chain wheel 1" Z9
81259	1	Chain 1"
81261	2	Bearing 6210 2RS
81266	2	Spring tensioner
81268	1	Rubber plug 37x3
81269	2	Rubber grommet 12x7
81270	1	Motor
81271	1	Sealkit, motor
81272	1	Sealkit, brake
81276	2	Film holder upside
81277	2	Upper axle
81278	2	Spring

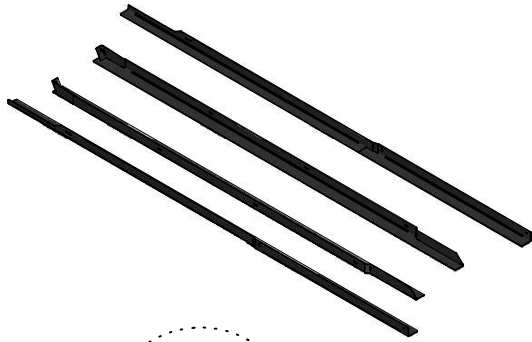

78457
Chain covers
page 2



79300
Bale tipper
page 5

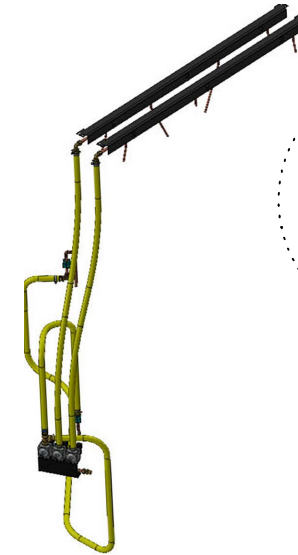

82124
Compressed air
cleaner system
page 4

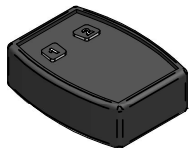

80654
Remote controller
page 6



77727
Airbrakes
page 3

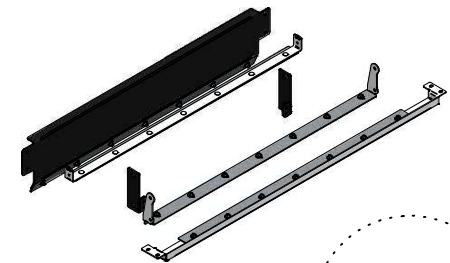

79729
Sticky material kit
page 7

79000
Additional oil cooler
page 8

Part Number	Qty.	Title
77751	1	Chain cover, left feed hopper
77752	1	Chain cover, right feed hopper
77753	1	Chain cover, left elevator
77754	1	Chain cover, right elevator

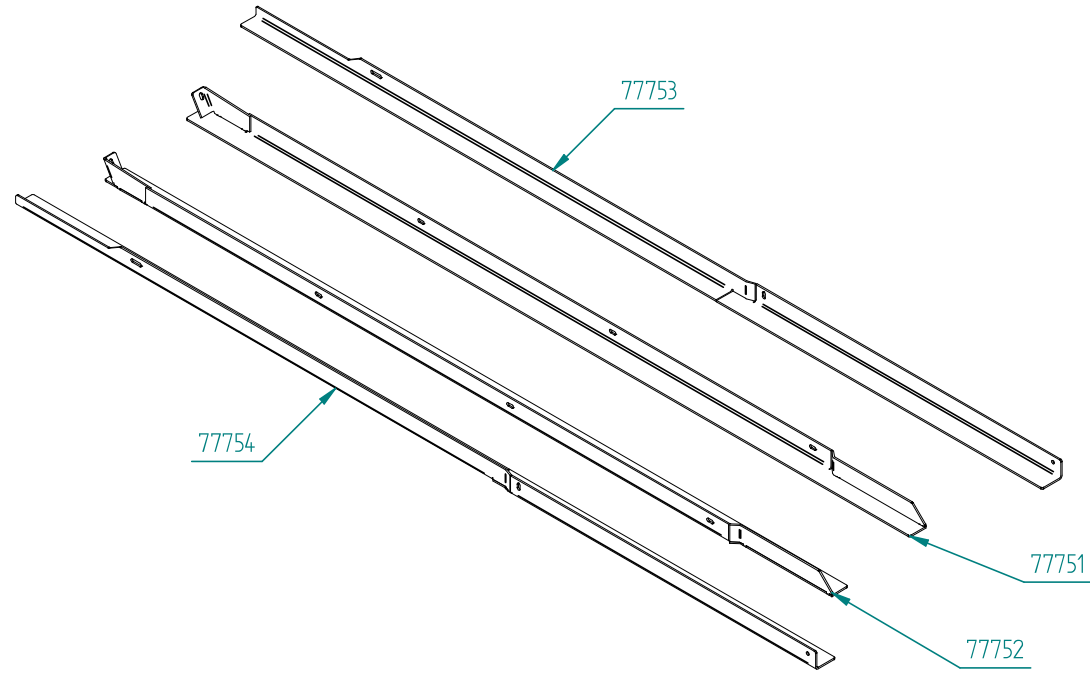

Part Number	Qty.	Title
59336	14	Hose clamp 15-24mm
59352	2	Filter
59353	1	Release valve
59354	1	Brake valve
59355	1	Air tank
59356	2	Clamp for air tank
59357	1	Tank valve
59358	3	Plug M22
59359	3	Nipple M16
59360	11	Nipple M22
59361	1	Coupling head
59362	1	Coupling head
59363	25	Hose
77403	1	Bracket, brake valves, air brakes

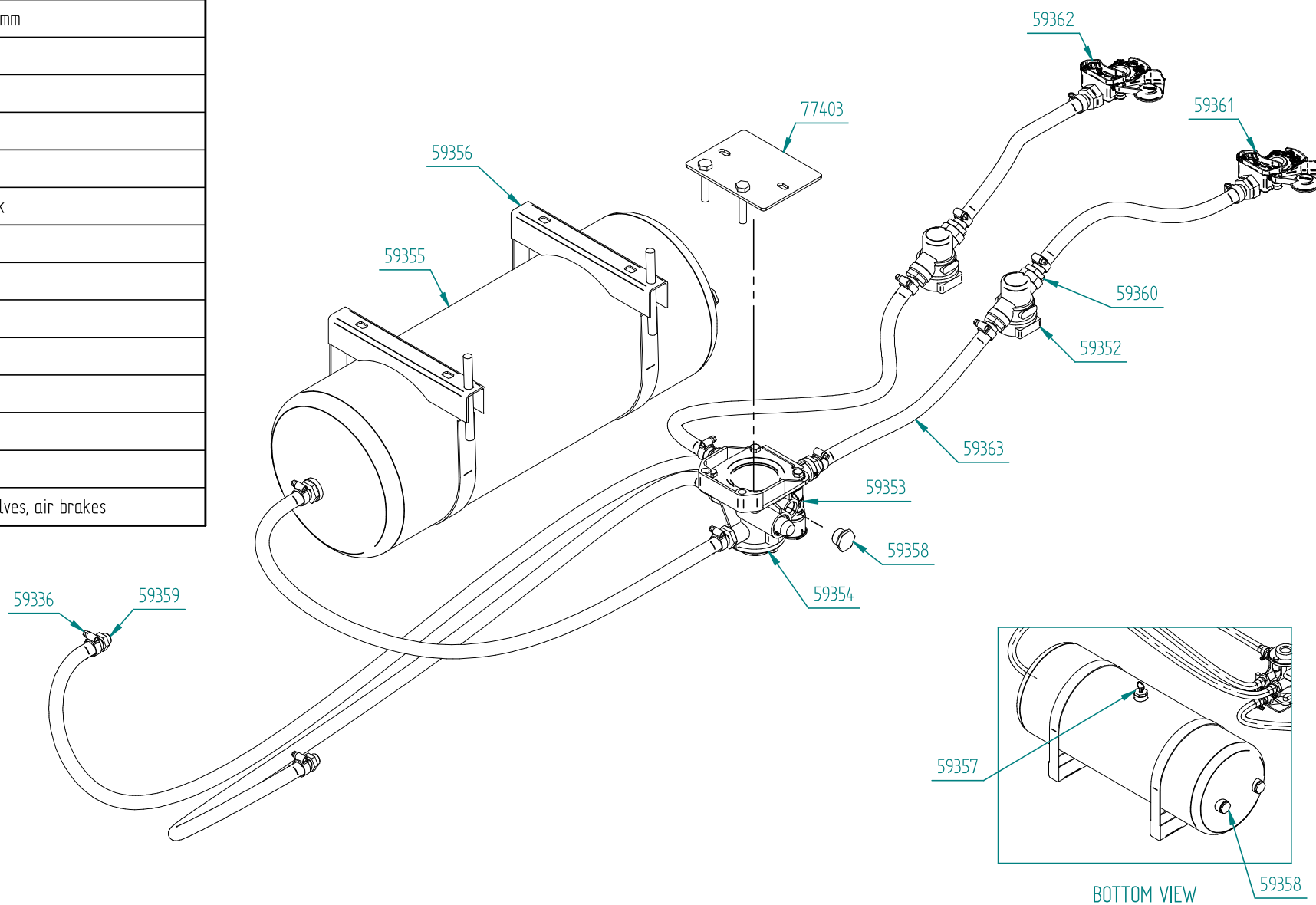

Airbrakes

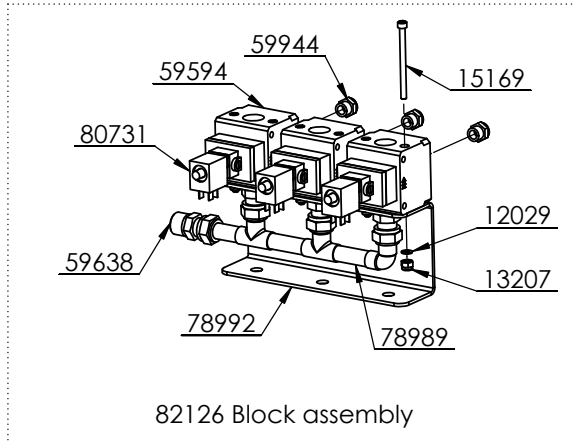
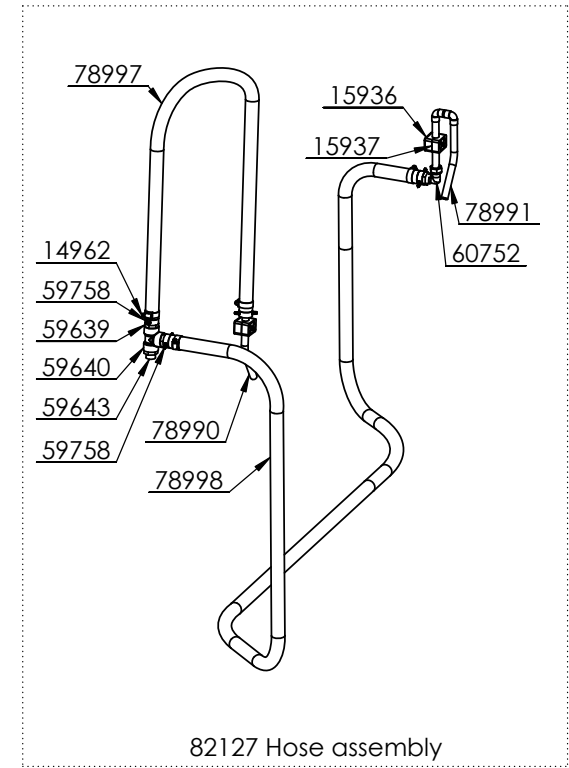
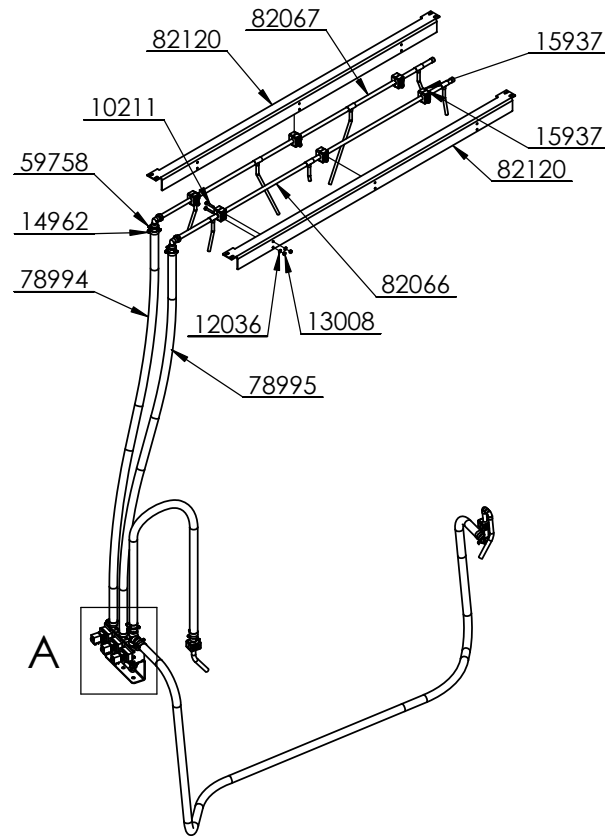
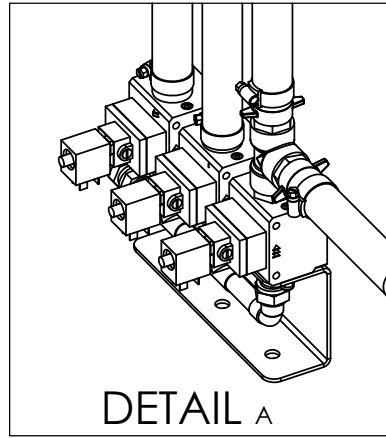

82126 Block assembly

82127 Hose assembly

Part number	Qty	Description
12029	6	Washer M5 DIN 125A
13207	6	Nut M5 DIN 985
15169	6	Bolt M5 x 70 ISO 4762
59594	3	Block valve
59638	4	Pipe coupling
59944	3	Filter plug 1/4"
78989	1	Branch tube
59634	2	T-connection, copper
59636	1	Elbow 15mm, copper
78992	1	Bracket for valves
80731	3	Coil 24 Vdc/48Vac 3,1W

Part number	Qty	Description
10211	12	Bolt M6x35
12036	12	Washer 6,4 DIN 125A -140HV FZV
13008	12	Nut M6
14962	4	Hose clamp 22-32mm
15937	12	Tube clamp, plastic
59758	4	Hose tail
78994	1	Airhose 1, film system L=2500
78995	1	Airhose 2, film system L=2500
82066	1	Complete tubing front, air cleaning
82067	1	Complete tubing rear, air cleaning
82120	2	Railing, air cleaning system,
82126	1	Block assembly
82127	1	Hose assembly

Part number	Qty	Description
14962	4	Hose clamp 22-32mm
15936	2	Top plate for plastic tube clamp
15937	4	Tube clamp, plastic
59638	1	Pipe coupling
59639	3	Transition nipple
59640	1	Tee tube
59643	1	Nipple 3/4" x 1/2"
59758	4	Hose tail
60752	1	Swaged elbow coupling
78990	1	Tube for spill tray right
78991	1	Tube for spill tray left
59636	2	Elbow 15mm, copper
78990	1	Tube for spill tray right
78997	1	Airhose 1, spill tray L=450
78998	1	Airhose 2, spill tray L=3100

Part Number	Qty.	Title
10207	1	Bolt M6x25, threaded to head
10307	4	Bolt M10x50
10493	1	Bolt M16x50
11110	3	Lockinghead bolt M10x100
11138	2	Locking head bolt M16x50
12060	11	Washer M10
12078	3	Washer M16
12278	1	Spring washer M16
13008	1	Nut M6
13043	7	Lock nut M10
13213	4	Lock nut M16
15202	2	Bolt M16x130, threaded to head
78850	2	Shim
78851	2	Spacer
78852	2	Lock washer
79297	1	Frame, triangle
79298	1	Bale stopper
79299	1	Support leg
79301	1	Bracket
79315	2	Stopper
79391	1	PVC pipe triangle
79392	1	PVC pipe vertical
79393	1	Bracket front
81305	1	Locking bolt with pin, 19x95

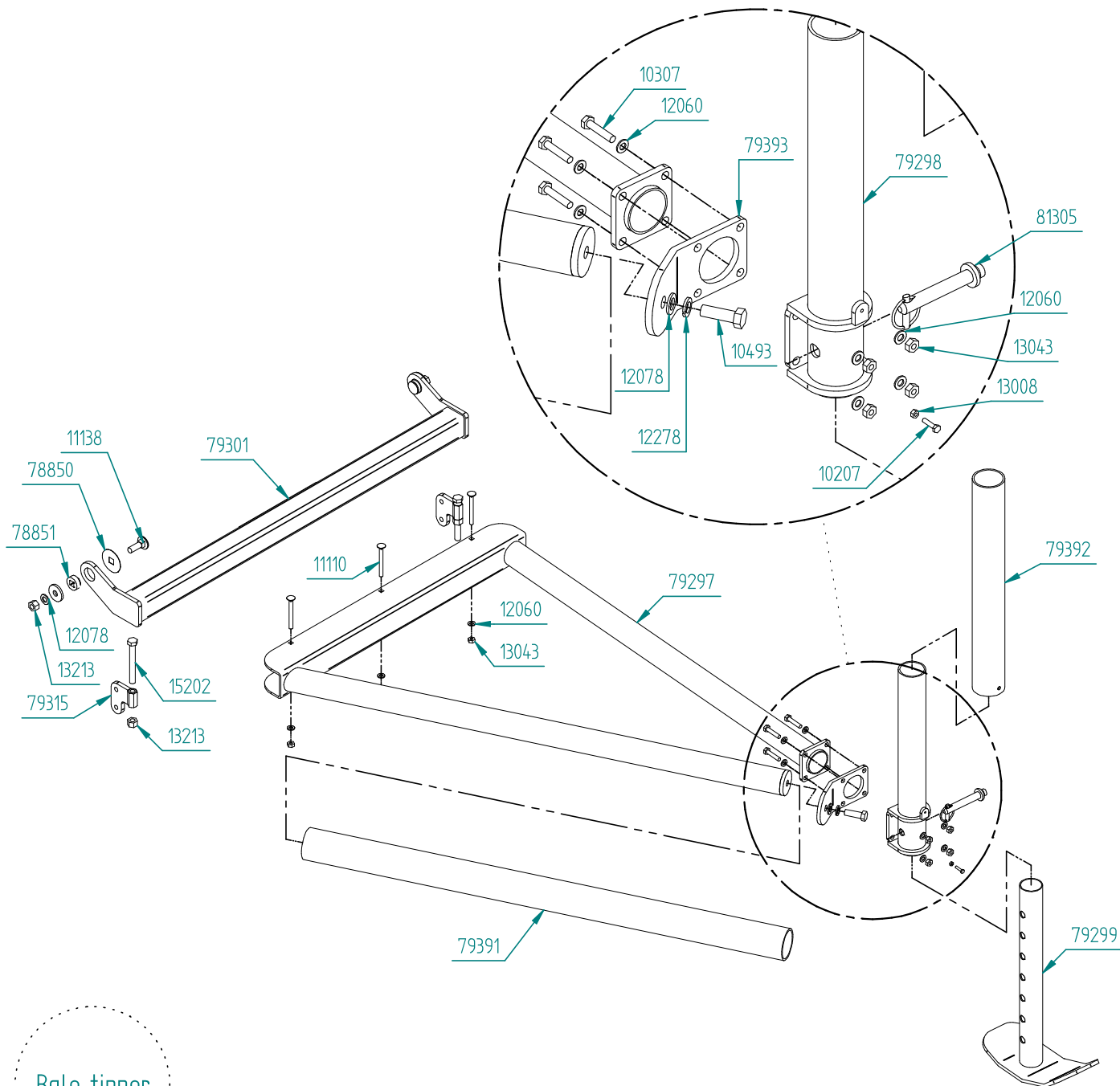

Bale tipper

Part Number	Qty.	Title
80654	1	Remote controller

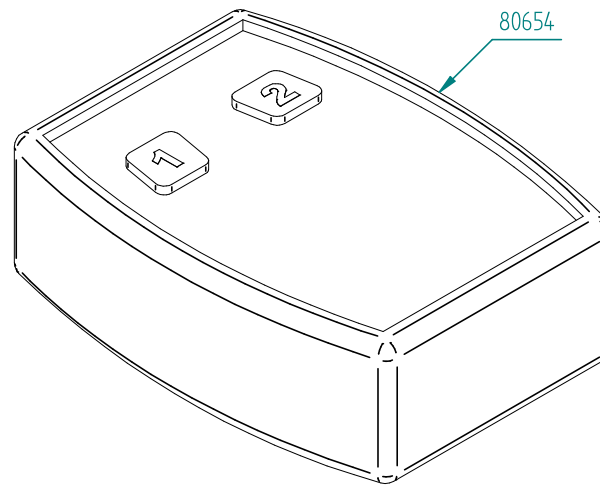

Remote controller

Part Number	Qty.	Title
11113	28	Locking head bolt M8x20
12147	28	Washer $\varnothing 24/8,4 \times 2$
13209	28	Lock nut M8
79665	1	Scraper @belt tensioner, front chamber
79784	4	Scraper blade
79785	1	Blade holder
79786	1	Blade holder
79787	1	Blade holder

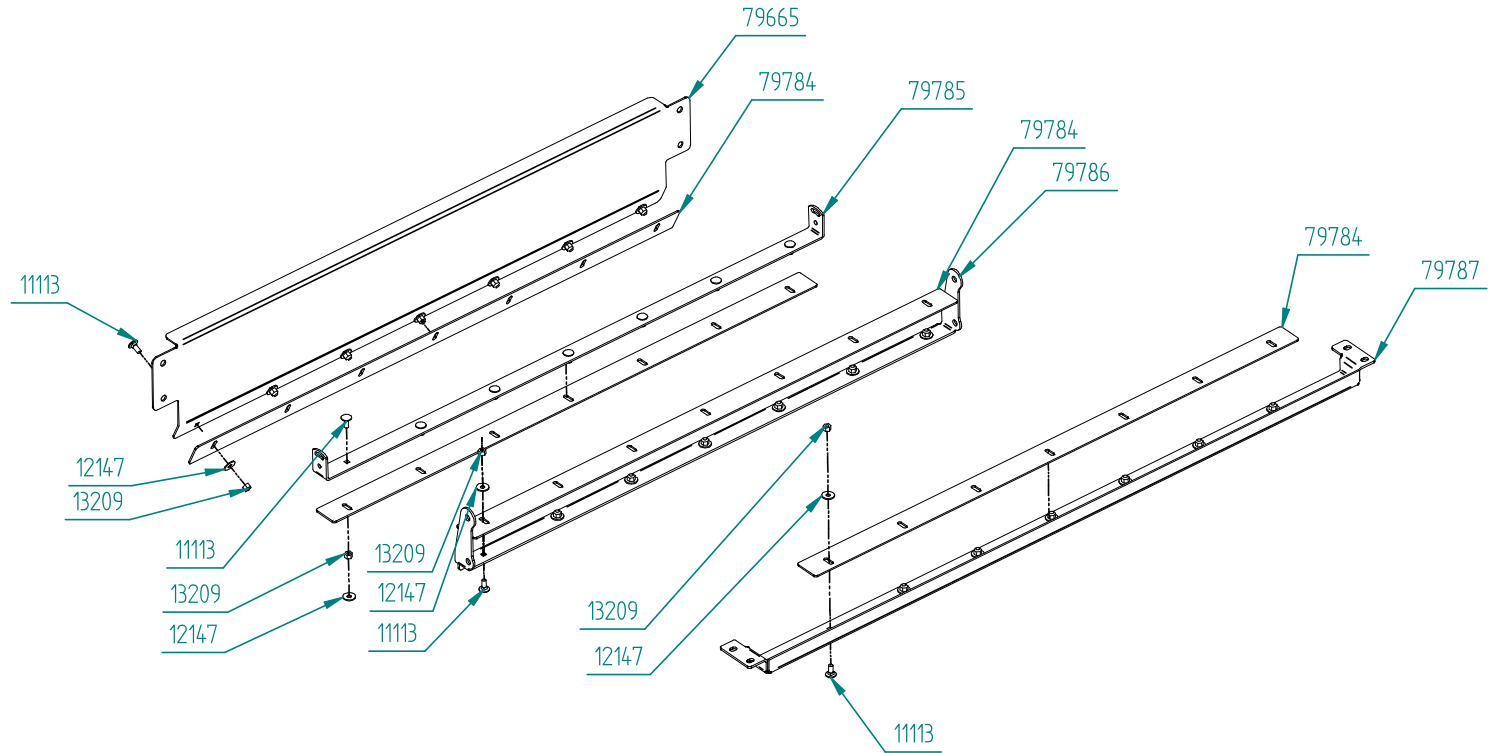

Sticky
material
kit

Part Number	Qty.	Title
57313	1	Tee connection 3/4"
59076	1	Thermostat
59176	2	Gasket 1 1/4"
59625	1	Hydraulic hose 3/4" 1SN L=2650 mm
67296	1	Transition
79001	1	Bracket upper, additional oil cooler
79002	1	Bracket lower, additional oil cooler
79427	1	Bracket
80542	1	Hydraulic hose 1/2" 2SN L=2800 mm
80882	1	Oil cooler SCM A65
80906	1	Hydraulic hose 3/4" 1SN L=3900 mm

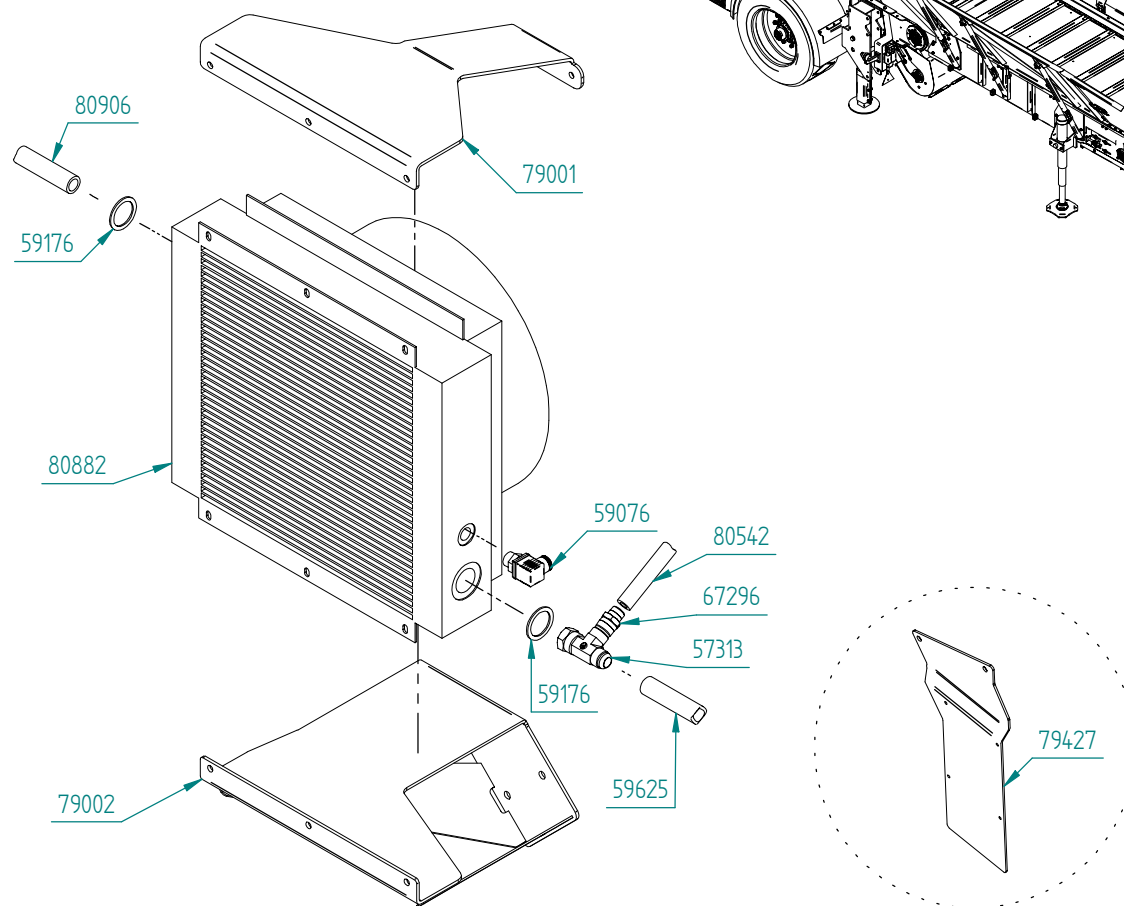
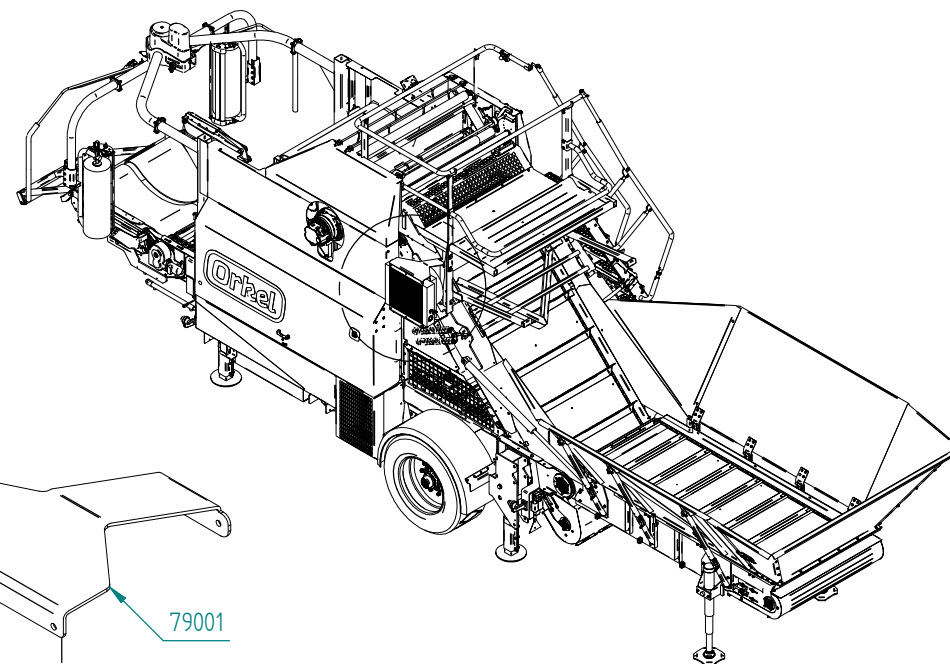

Additional
oil cooler
79000



78772

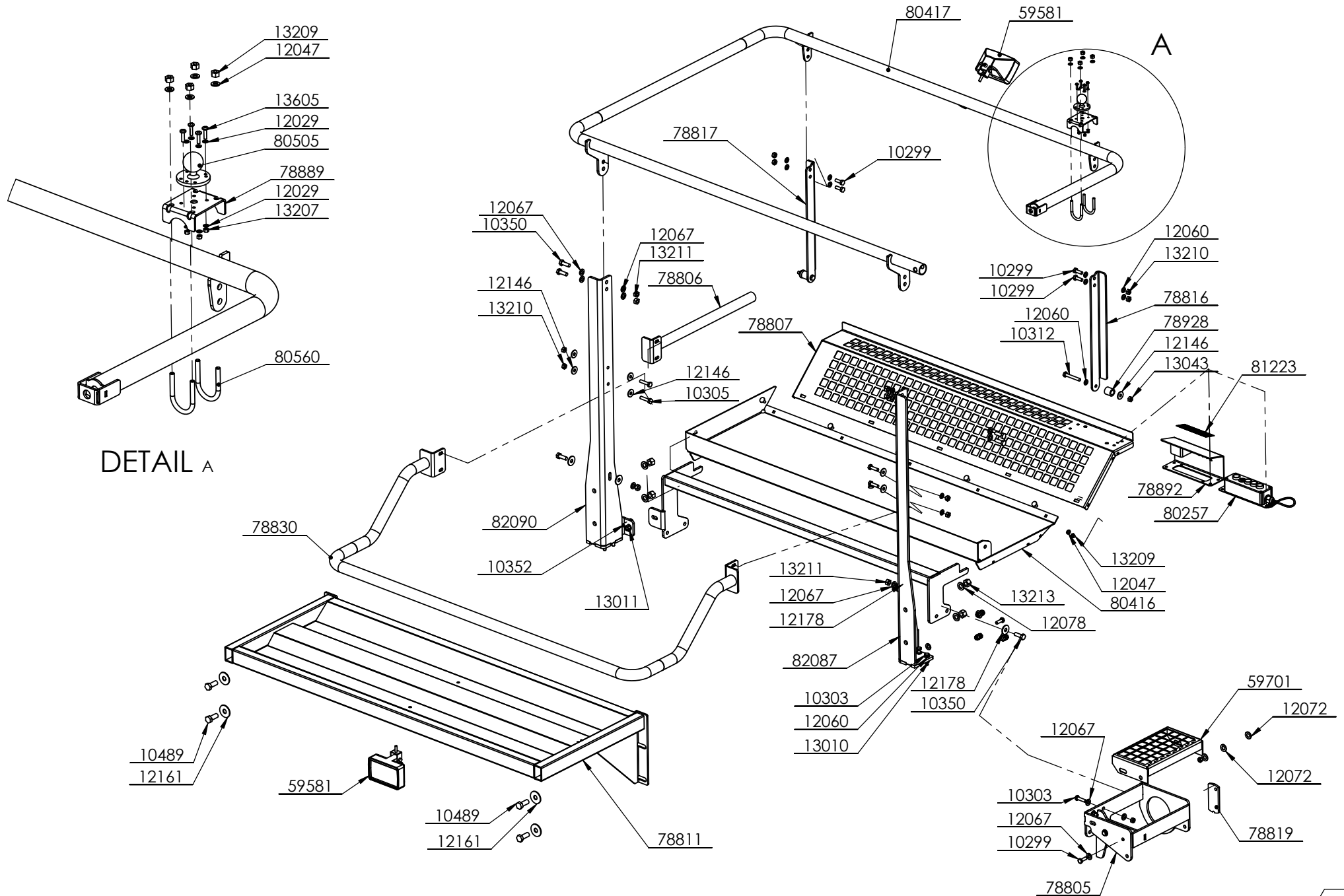

DETAIL A

Part number	Qty	Description
10297	1	Screw M10 x 25 DIN 933
10299	4	Bolt M10 x 30 DIN 933 8.8 FZV
10299	4	Screw M10 x 30 DIN 933
10301	2	Bolt M10 x 35 DIN 933 8.8 FZV
10303	8	Screw M10 x 40 DIN 933
10305	2	Bolt M10x45
10350	6	Bolt M12x35
10352	2	Bolt M12 x 40 DIN 933
10489	4	Bolt M16 x 40 DIN 933 8.8 FZV
11113	5	Bolt M8x20 DIN 603 A4 80
12029	8	Washer M5
12047	9	Washer 8,4 DIN 125A -140HV FZV
12060	11	Washer 10,5 DIN 125A -140HV FZV
12060	18	Washer M10 DIN 125A
12067	10	Washer 13 DIN 125A -140HV FZV
12072	4	Washer M14 DIN 125A
12078	4	Washer 17 DIN 125A -140HV FZV
12146	8	Washer 10,5x30x2,5 DIN 9021 FZV
12161	4	Washer 17 x 50 x 3 DIN 9021 FZV
12178	4	Washer 13 x 37 x 3 DIN 9021 FZV
13010	13	Nut M10 DIN 934
13011	1	Nut M12 DIN 934
13207	4	Lock nut M5
13209	9	Lock nut M8
13210	8	Lock nut M10
13211	6	Lock nut M12
13213	4	Lock nut M16
13605	4	Pan bolt M5x20
59581	2	Flood light
59701	1	Step
78805	1	Fastener for staircase and platform
78806	1	Middle tube
78807	1	Top cover
78811	1	Underframe, storage
78816	1	Supporting rod, right
78817	1	Supporting rod, left
78819	1	Support for step
78830	1	Rear bow, storage
78889	1	Fastener for RAM bracket
78891	1	Bottom plate, remote control, film system
78892	1	Cover, remote control, film system

Part number	Qty	Description
78928	2	Spacer
80257	1	Switch box for film system
80412	1	Frame for platform
80416	1	Bottom plate
80417	1	Railing tube
80505	1	RAM-fastener, foot
80560	2	U-clamp 42mm
81223	1	Sticker
82087	1	Upper tower with brackett, right, platform
82090	1	Upper tower with brackett, left, platform
10297	1	Bolt M10 x 25 DIN 933 8.8 FZV
13043	2	Lock nut M10
10312	2	Bolt M10 x 70 DIN 931 8.8 FZV
12067	11	Washer M12 DIN 125A
13010	1	Nut M10

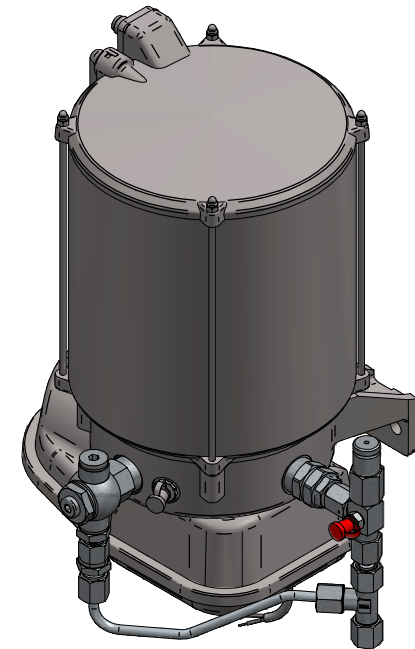
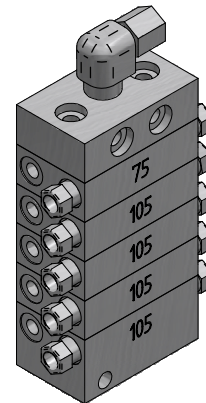
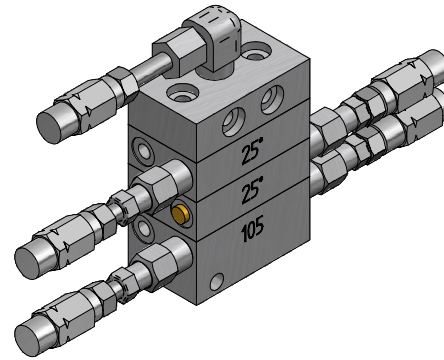
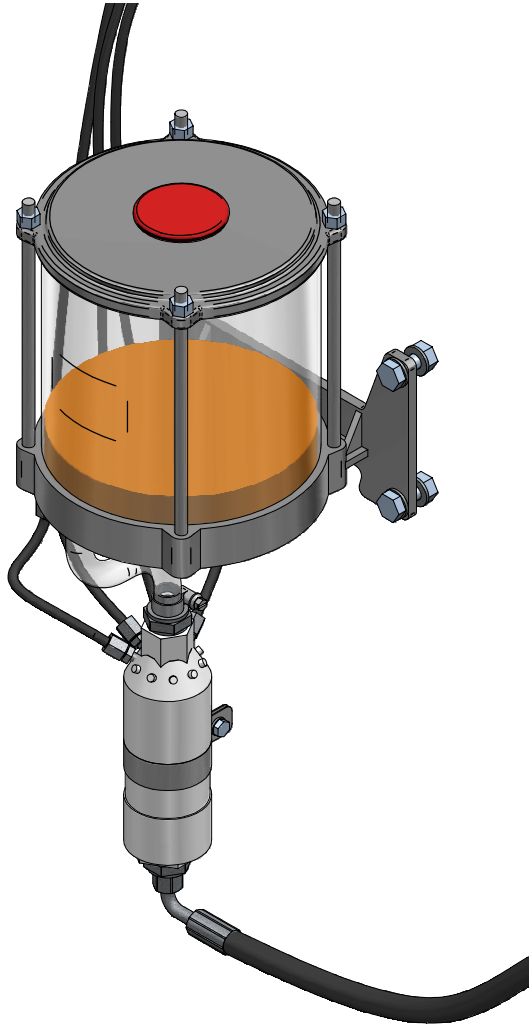

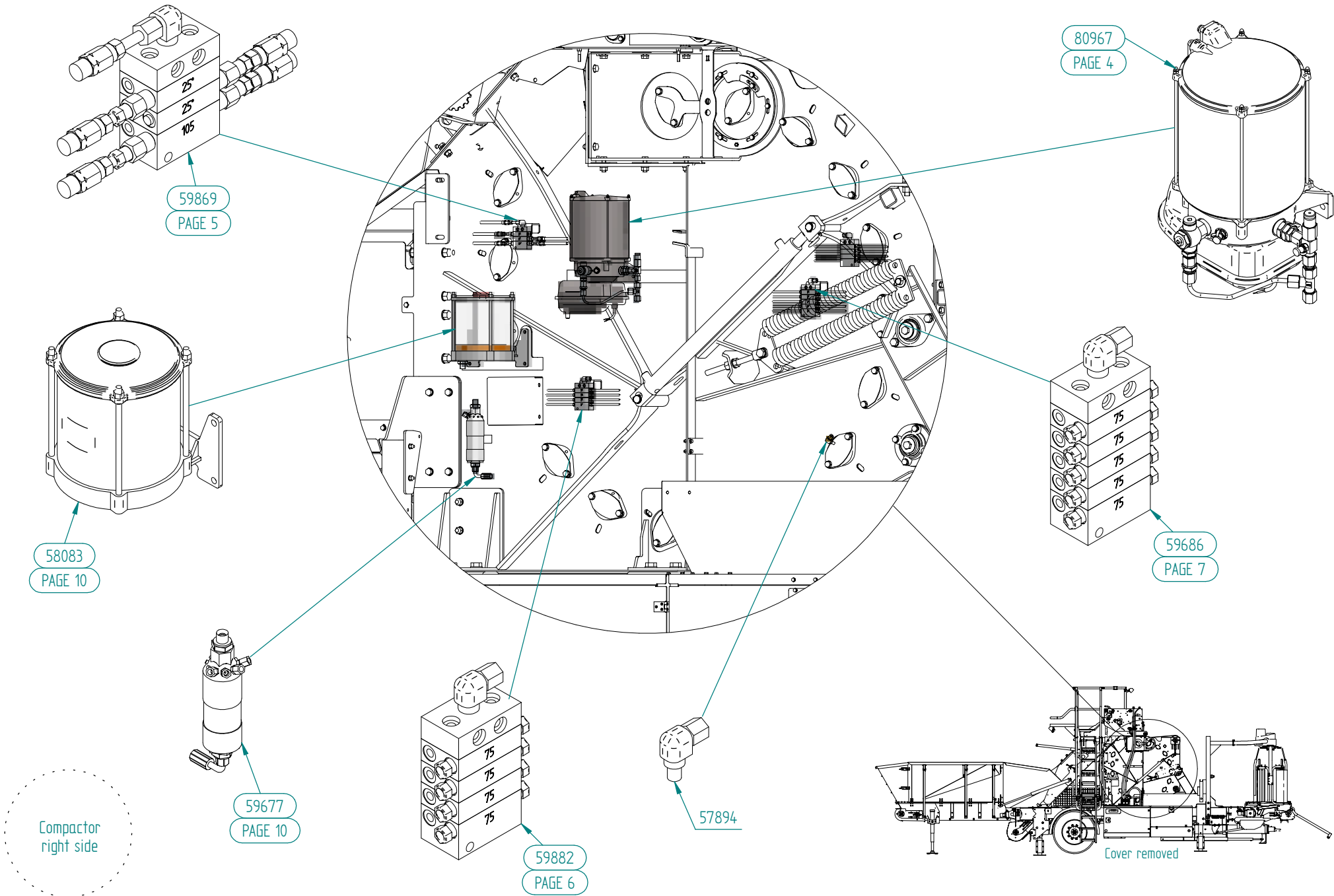

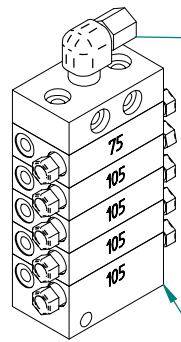

59688
PAGE 8

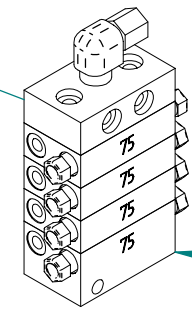
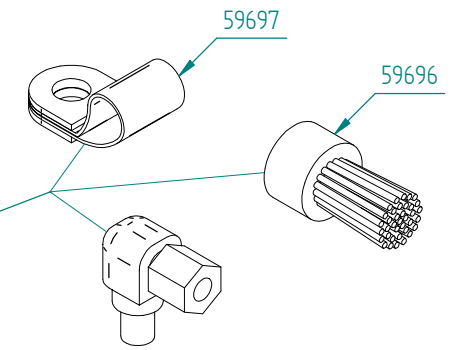
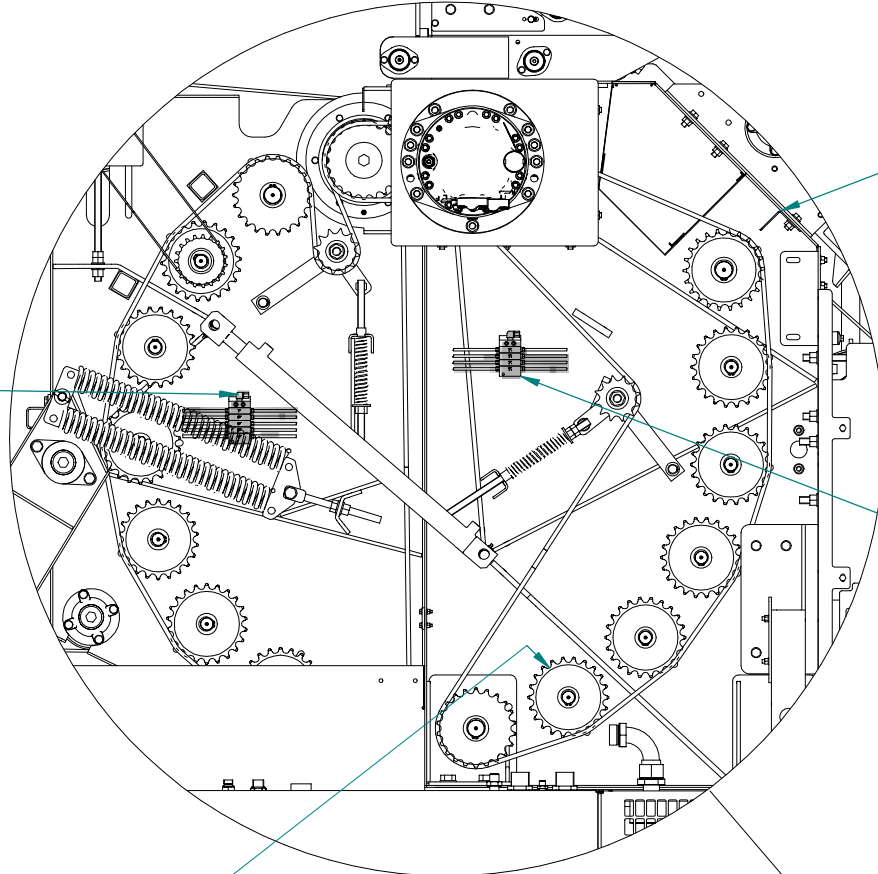

59690
PAGE 9

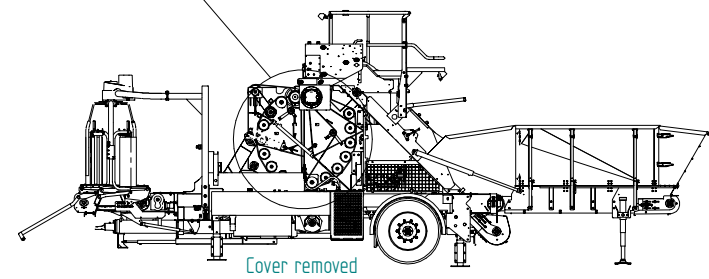
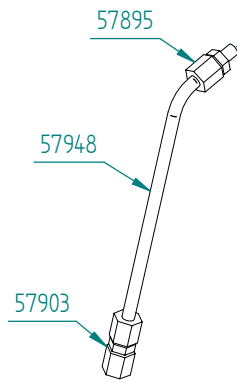

Cover removed

Compactor
left side

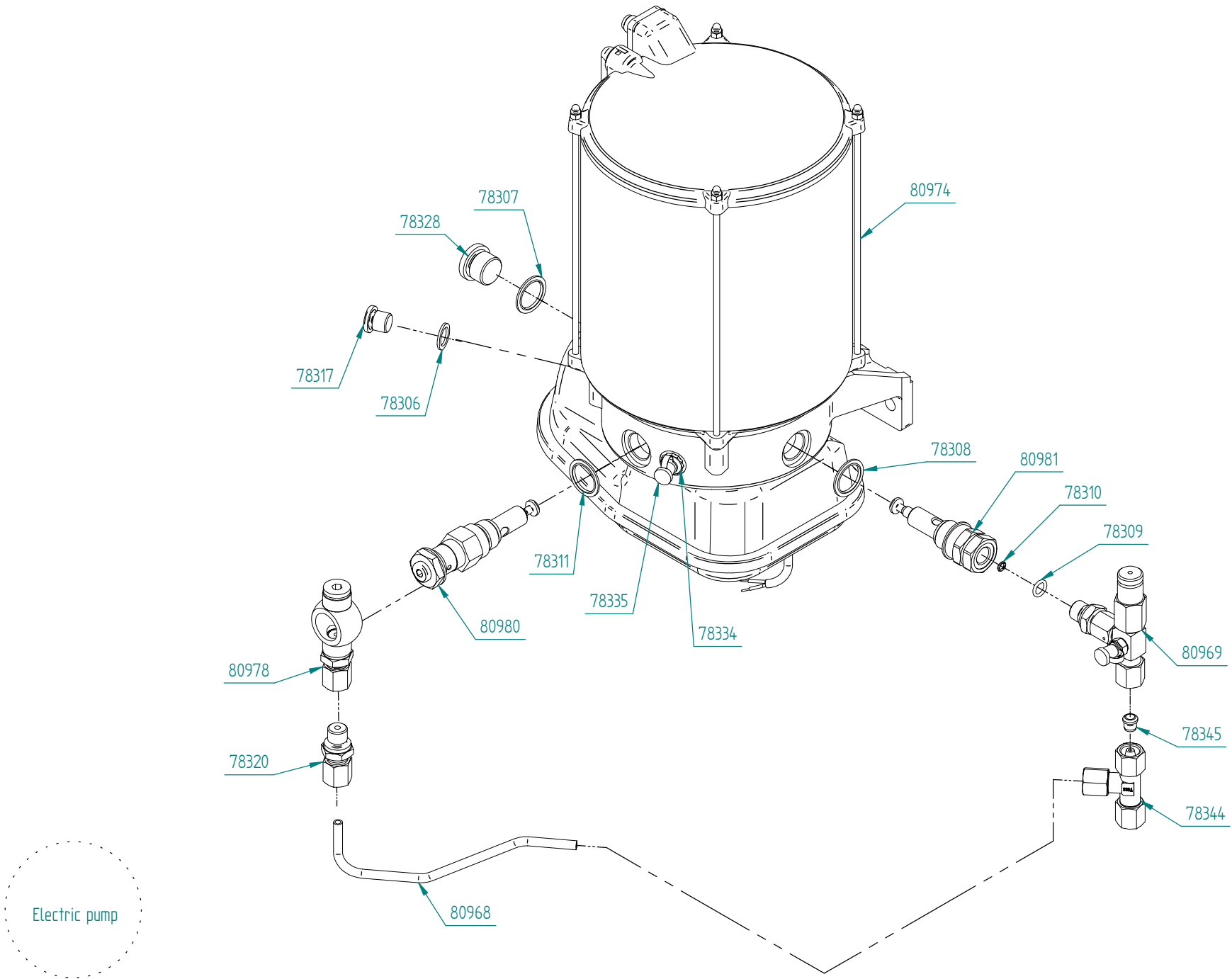

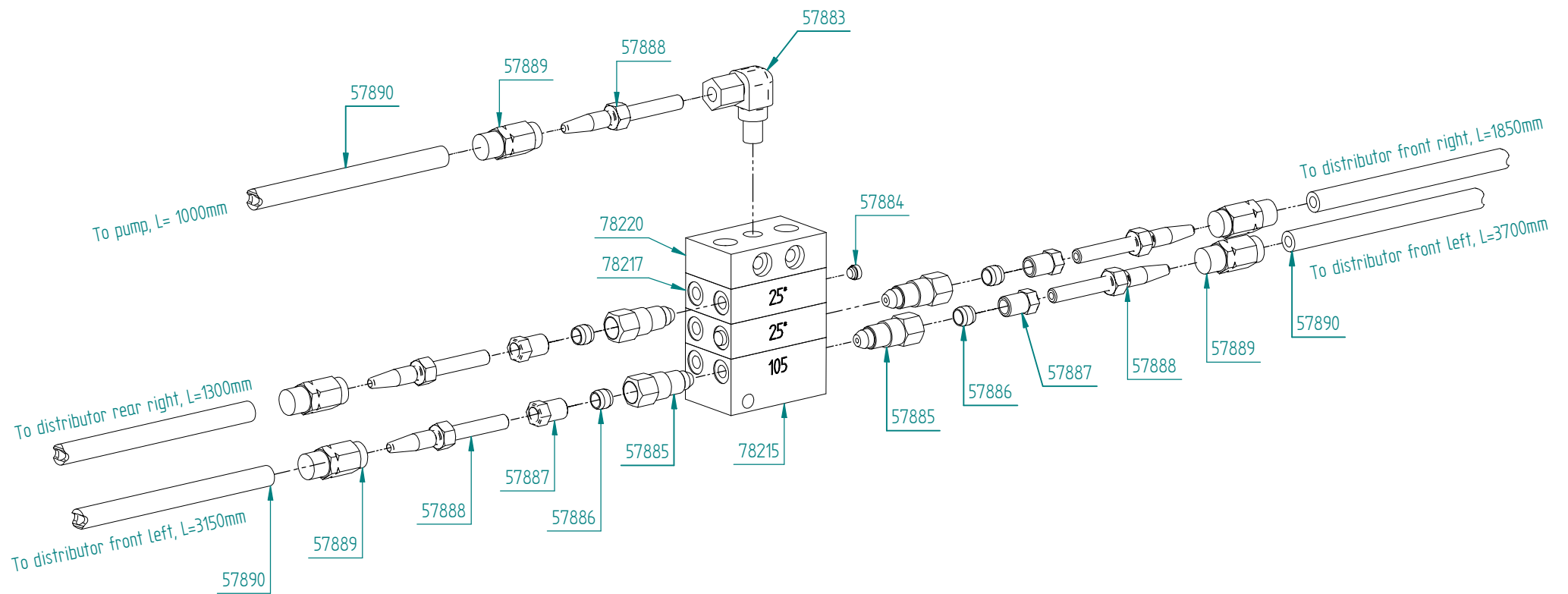

Main distributor

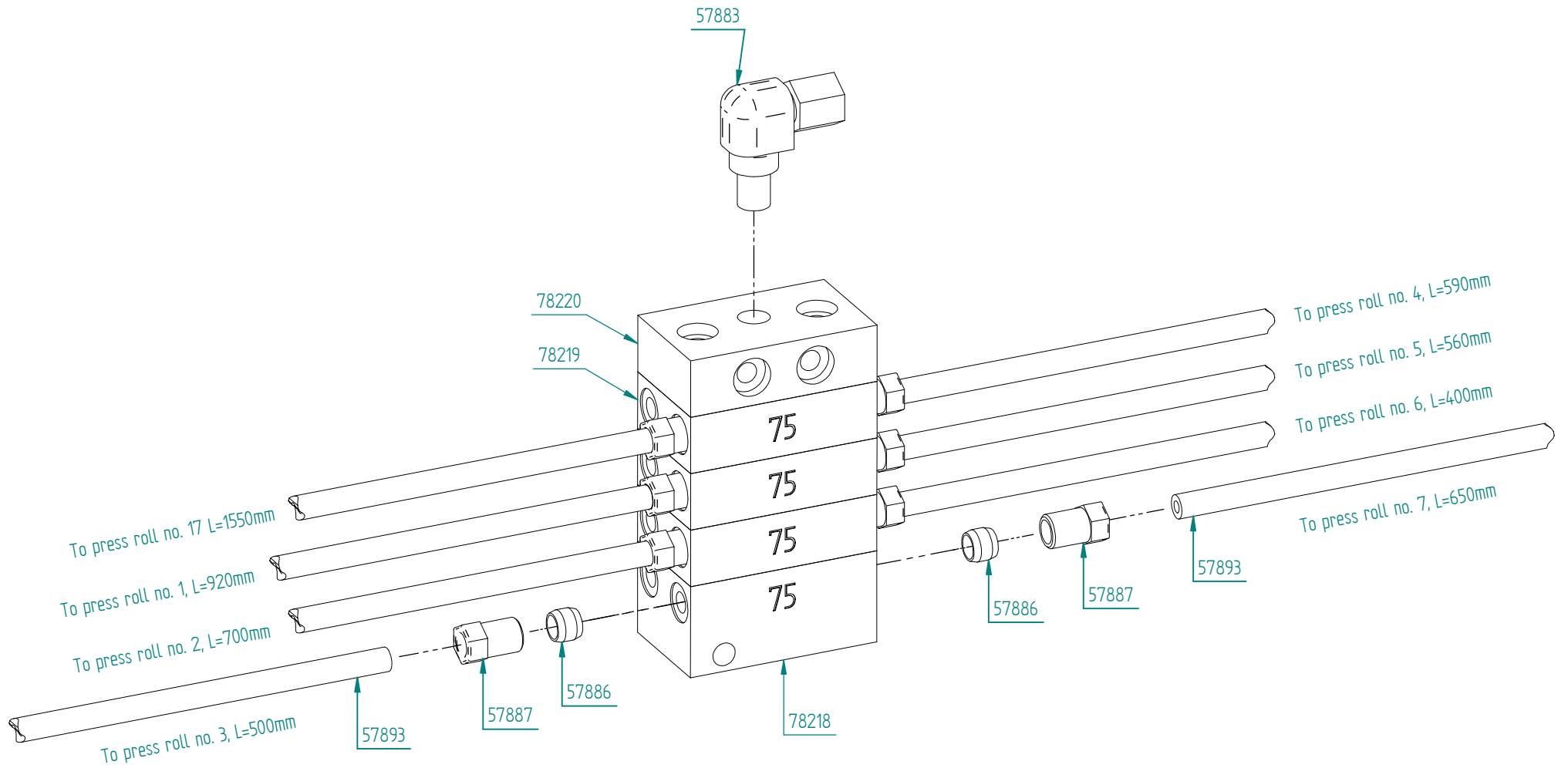

Distributor
rear right

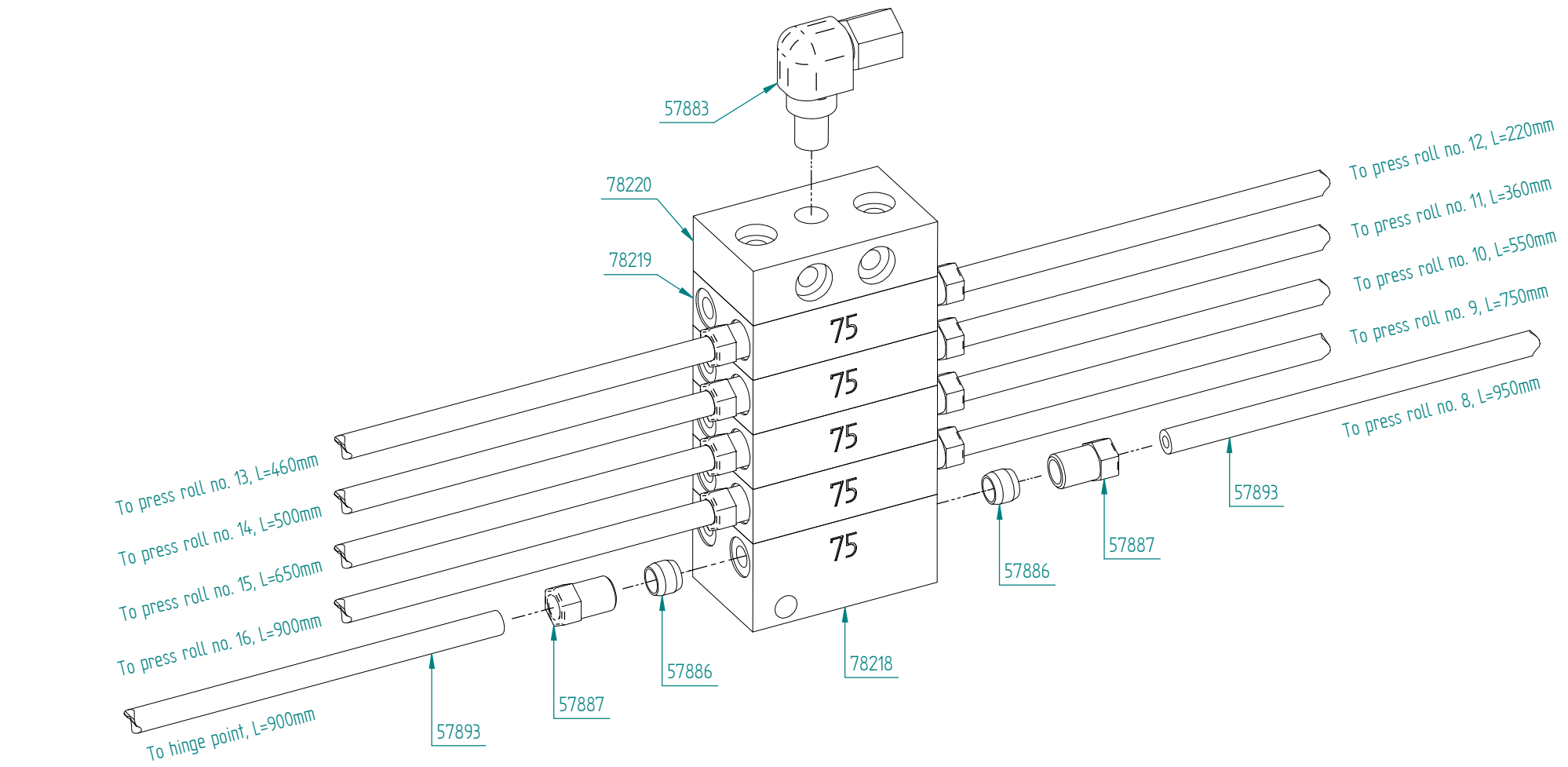

Distributor
front right

Distributor
front left

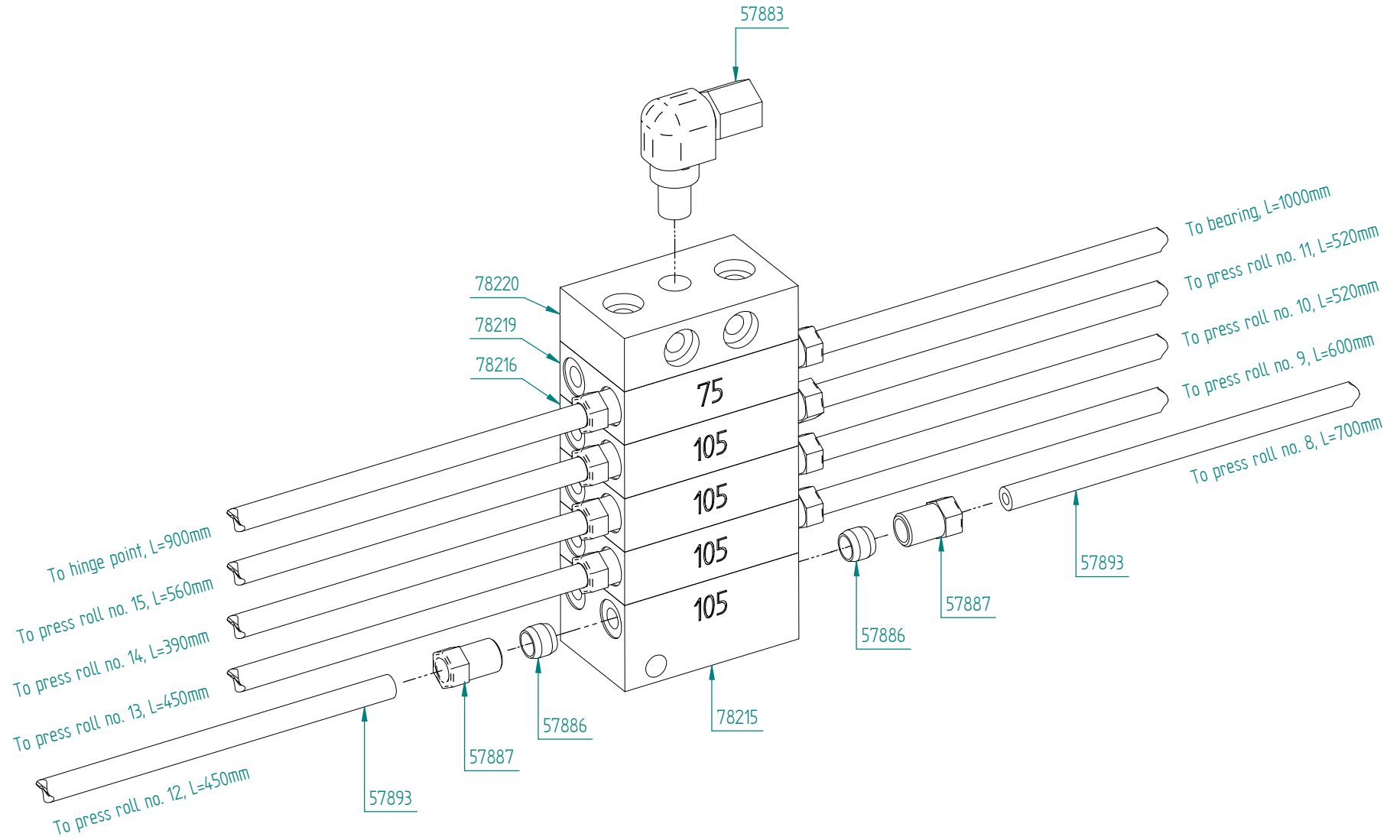

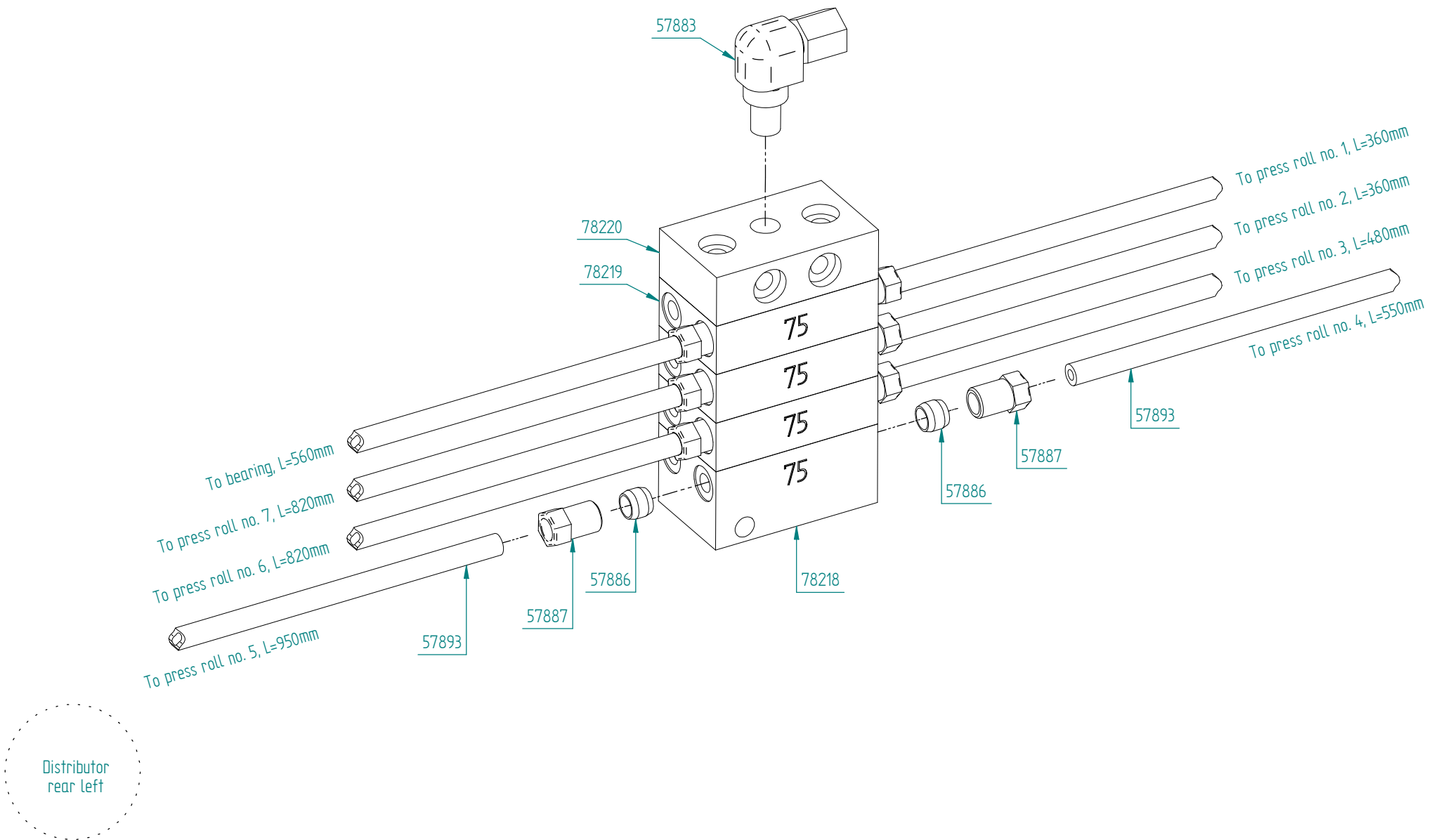

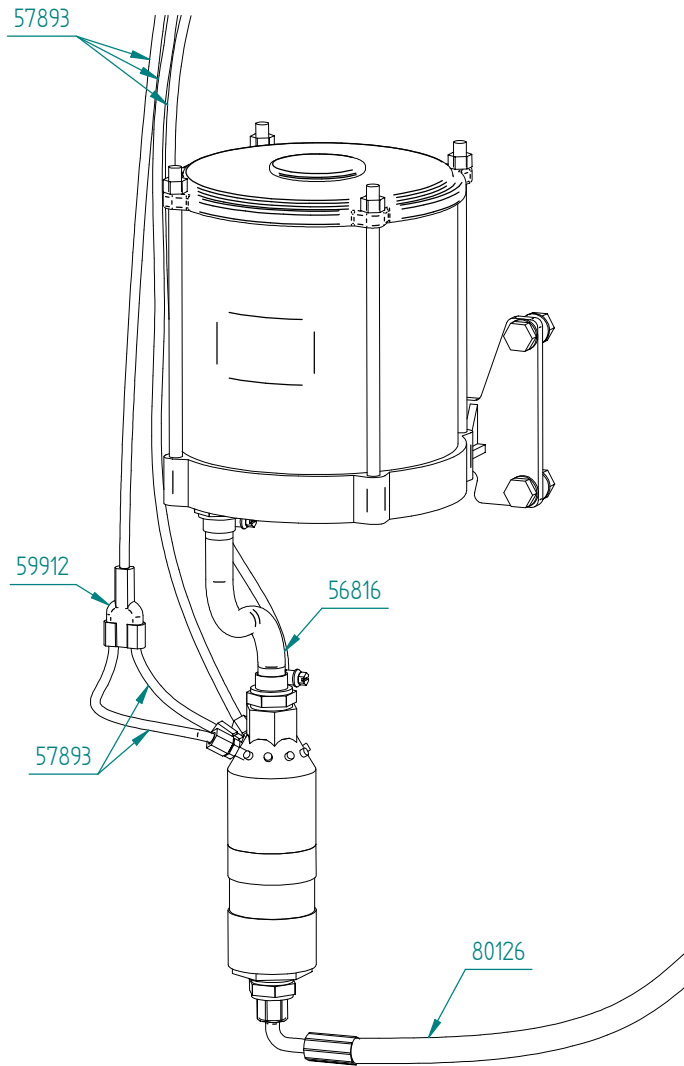

Hydraulic oil pump
and oil tank

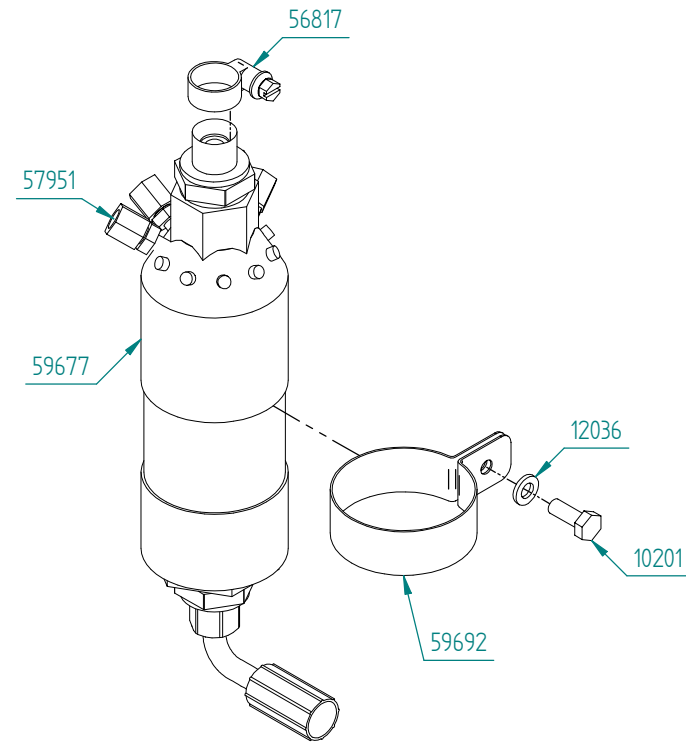
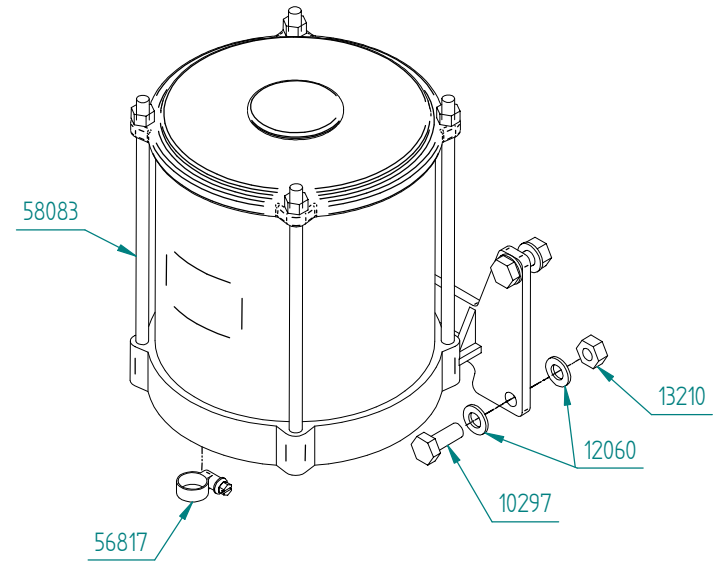

Part Number	Qty.	Title
10201	1	Bolt M6x16, threaded to head
10297	6	Bolt M10x25
12036	1	Washer M6
12060	12	Washer M10
13210	6	Lock nut M10
56816	1	PVC hose
56817	2	Worm gear clamp
57883	5	Angular coupling 90° WE6 1/8"
57884	2	Sealing plug
57885	4	Non-return valve
57886	40	Double Cone Olive
57887	40	Cap screw US6 M10x1
57888	9	Insert for ferrule
57889	9	Threaded ferrule
57890	m	High Pressure Hose
57893	m	Polyamid Tube
57894	13	Elbow 90° WEG 1/8" K
57895	21	Fitting GE 6LI R1/8" k
57896	1	Spiral protection ø8x4 (Not shown)
57903	16	Fitting
57948	1	Steel tube, ø6x1, galvanized
57951	2	Fitting
58083	1	Oil reservoir
59677	1	Hydraulic pump

Part Number	Qty.	Title
59686	1	Distributor front right
59688	1	Distributor front left
59690	1	Distributor rear left
59692	1	Clamp
59696	6	Grease brush
59697	6	Tube bow ø15
59869	1	Main distributor
59882	1	Distributor rear right
59910	6	Elow builtow M8x1
59912	1	Fitting Y-type
78215	2	Distribution block, MX-F 105, large
78216	3	Distribution block, MX-F 105, small
78217	2	Distribution block, MX-F 25, small
78218	3	Distribution block, MX-F 75, large
78219	11	Distribution block, MX-F 75, small
78220	5	Distribution block, MX-F 105, main
78306	1	EP-1, gasket 1
78307	1	EP-1, gasket 2
78308	1	EP-1, gasket 3
78309	1	EP-1, gasket 4
78310	1	EP-1, gasket 5
78311	1	EP-1, gasket 6
78317	1	EP-1, fitting 1
78320	1	EP-1, fitting 4

Part Number	Qty.	Title
78328	1	EP-1, container, part 4
78334	1	EP-1, grease nipple
78335	1	EP-1, cap for grease nipple
78344	1	EP-1, valve 3, part 1
78345	1	EP-1, valve 3, part 2
80126	1	Hydraulic hose 1/4" 2SN L=580
80967	1	Greasepump EP-1 24V complete
80968	1	EP-1, contact for 80967
80969	1	EP-1, valve
80974	1	Greasepump EP-1 24V
80978	1	Banjo union
80980	1	Pump element PE-120V
80981	1	Pump element PE-170GI



Developing profitable customers

CONTACT



Johan Gjønnes' veg 25
7320 Fannrem
Norway



Spare parts:
+47 913 23 511

Technical Support:
+47 918 43 553



parts@orkel.no



orkel.com

User resources



orkel.no/qr/mp2000-x